



---

*Service & Maintenance Manual*

*Model(s)*  
*DVL &*  
*DVSP*  
*Series*

*P/N - 3121136*

*September 27, 2005*

**ANSI**



**CE**





## MAINTENANCE SAFETY PRECAUTIONS

### A. GENERAL

This section contains the general safety precautions which must be observed during maintenance of the aerial platform. It is of utmost importance that maintenance personnel pay strict attention to these warnings and precautions to avoid possible injury to themselves or others or damage to the equipment. A maintenance program must be established by a qualified person and must be followed to ensure that the machine is safe to operate.

#### **⚠ WARNING**

**MODIFICATION OF THE MACHINE WITHOUT CERTIFICATION BY A RESPONSIBLE AUTHORITY THAT THE MACHINE IS AT LEAST AS SAFE AS ORIGINALLY MANUFACTURED IS A SAFETY VIOLATION.**

The specific precautions to be observed during machine maintenance are inserted at the appropriate point in the manual. These precautions are, for the most part, those that apply when servicing hydraulic and larger machine component parts.

Your safety, and that of others, is the first consideration when engaging in the maintenance of equipment. Always be conscious of component weight and never attempt to move heavy parts without the aid of a mechanical device. Do not allow heavy objects to rest in an unstable position. When raising a portion of the equipment, ensure that adequate support is provided.

#### **⚠ WARNING**

**SINCE THE MACHINE MANUFACTURER HAS NO DIRECT CONTROL OVER THE FIELD INSPECTION AND MAINTENANCE, SAFETY IN THIS AREA IS THE RESPONSIBILITY OF THE OWNER/ OPERATOR.**

### B. HYDRAULIC SYSTEM SAFETY

1. It should be particularly noted that the machines hydraulic systems operate at extremely high and potentially dangerous pressures. Every effort should be made to relieve any system pressure prior to disconnecting or removing any portion of the system.
2. Relieve system pressure by activating the lift DOWN control with the platform completely lowered to direct any line pressure back into the return line to the reservoir. Pressure feed lines to system components can then be disconnected with minimal fluid loss.

### C. MAINTENANCE

#### **⚠ WARNING**

**FAILURE TO COMPLY WITH SAFETY PRECAUTIONS LISTED IN THIS SECTION COULD RESULT IN MACHINE DAMAGE, PERSONNEL INJURY OR DEATH AND IS A SAFETY VIOLATION.**

- REMOVE ALL RINGS, WATCHES, AND JEWELRY WHEN PERFORMING ANY MAINTENANCE.
- DO NOT WEAR LONG HAIR UNRESTRAINED, OR LOOSE FITTING CLOTHING AND NECKTIES WHICH ARE APT TO BECOME CAUGHT ON OR ENTANGLED IN EQUIPMENT.
- OBSERVE AND OBEY ALL DANGER, WARNING, CAUTION AND OTHER INSTRUCTIONS ON MACHINE AND IN SERVICE MANUAL.
- KEEP STANDING SURFACES AND HAND HOLDS FREE OF OIL, GREASE, WATER, ETC.
- NEVER WORK UNDER AN ELEVATED PLATFORM UNTIL PLATFORM HAS BEEN SAFELY RESTRAINED FROM ANY MOVEMENT BY BLOCKING OR OVER-HEAD SLING.
- BEFORE MAKING ADJUSTMENTS, LUBRICATING OR PERFORMING ANY OTHER MAINTENANCE, SHUT OFF ALL POWER CONTROLS.
- BATTERY SHOULD ALWAYS BE DISCONNECTED DURING REPLACEMENT OF ELECTRICAL COMPONENTS.
- KEEP ALL SUPPORT EQUIPMENT AND ATTACHMENTS STOWED IN THEIR PROPER PLACE.
- USE ONLY APPROVED, NONFLAMMABLE CLEANING SOLVENTS.

## REVISION LOG

October 4, 2001 – Original Issue of Manual  
October 25, 2001 – Manual Revised  
November 12, 2001 – Manual Revised  
December 13, 2001 – Manual Revised  
February 22, 2002 – Manual Revised  
October 29, 2002 – Manual Revised  
January 22, 2003 – Manual Revised  
February 18, 2003 – Manual Revised  
July 18, 2003 – Manual Revised  
October 1, 2003 – Manual Revised  
August 16, 2004 – Manual Revised  
September 27, 2005 – Manual Revised

TABLE OF CONTENTS

SUBJECT - SECTION, PARAGRAPH	PAGE NO.
MAINTENANCE SAFETY PRECAUTIONS . . . . .	A
A GENERAL . . . . .	A
B HYDRAULIC SYSTEM SAFETY . . . . .	A
C MAINTENANCE . . . . .	A
REVISION LOG . . . . .	B
<b>SECTION 1 - MACHINE SPECIFICATIONS</b>	
1.1 CAPACITIES . . . . .	1-2
System Voltage . . . . .	1-2
Hydraulic System . . . . .	1-2
Drive Motor GearBox (gear oil) . . . . .	1-2
1.2 COMPONENT DATA . . . . .	1-2
Hydraulic Pump/Pump Motor Assembly . . . . .	1-2
Rear Wheel Drive Motors . . . . .	1-2
Batteries/Battery Charger . . . . .	1-2
1.3 PERFORMANCE DATA . . . . .	1-2
Platform Capacities . . . . .	1-2
Platform Size . . . . .	1-2
Machine Height (platform stowed) . . . . .	1-2
Base Footprint . . . . .	1-2
1.4 TORQUE REQUIREMENTS . . . . .	1-2
1.5 LUBRICATION . . . . .	1-3
Hydraulic Oil . . . . .	1-3
Lubrication Specifications . . . . .	1-3
1.6 HYDRAULIC PRESSURE SETTINGS AND ADJUSTMENT . . . . .	1-3
Hydraulic Pressure Gauge Connection . . . . .	1-4
After Filter Pressure Check . . . . .	1-4
1.7 CYLINDER SPECIFICATIONS . . . . .	1-4
1.8 SERIAL NUMBER LOCATIONS . . . . .	1-4
<b>SECTION 2 - GENERAL</b>	
2.1 MACHINE PREPARATION, INSPECTION, AND MAINTENANCE . . . . .	2-1
General . . . . .	2-1
Preparation, Inspection, and Maintenance . . . . .	2-1
Pre-Start Inspection . . . . .	2-1
Pre-Delivery Inspection and Frequent Inspection . . . . .	2-1
Annual Machine Inspection . . . . .	2-1
Preventative Maintenance . . . . .	2-1
2.2 PREVENTIVE MAINTENANCE AND INSPECTION SCHEDULE . . . . .	2-3
Inspection and Maintenance Codes: . . . . .	2-5
Footnotes: . . . . .	2-5
2.3 SERVICING AND MAINTENANCE GUIDELINES . . . . .	2-6
General . . . . .	2-6
Safety and Workmanship . . . . .	2-6
Cleanliness . . . . .	2-6

## TABLE OF CONTENTS

---

Components Removal and Installation . . . . .	2-6
Component Disassembly and Reassembly . . . . .	2-6
Pressure-Fit Parts . . . . .	2-6
Bearings . . . . .	2-6
Gaskets . . . . .	2-6
Bolt Usage and Torque Application . . . . .	2-6
Hydraulic Lines and Electrical Wiring . . . . .	2-7
Hydraulic System . . . . .	2-7
Lubrication and Servicing . . . . .	2-7
Batteries . . . . .	2-7
Mast Chain Inspection Procedure . . . . .	2-7
2.4 LUBRICATION INFORMATION . . . . .	2-8
Hydraulic System . . . . .	2-8
Hydraulic Oil . . . . .	2-8
Changing Hydraulic Oil . . . . .	2-8
Lubrication Specifications . . . . .	2-8
2.5 POSITIONING LIFT FOR ACCESS TO COMPONENTS LOCATED UNDER THE BASE FRAME . . . . .	2-9

### SECTION 3 - BASE COMPONENTS

3.1 BASE ASSEMBLY COMPONENTS . . . . .	3-1
3.2 BASE FRAME COVERS . . . . .	3-2
Drive Motor Cover - Installation . . . . .	3-2
Battery Charger Cover - Installation . . . . .	3-2
3.3 DRIVE AND CASTER WHEELS . . . . .	3-2
Drive Motor Wheel (Std.) - Installation . . . . .	3-2
Caster Wheels - Installation . . . . .	3-2
Wheel Retention for Rough Terrain Drive Wheel (Option) . . . . .	3-3
3.4 DRIVE MOTOR COMPONENT - SERVICING . . . . .	3-3
Torque Limiting Clutch Maintenance . . . . .	3-3
Diagnostics . . . . .	3-3
Visual Inspection and Limiting Torque Checking Procedure . . . . .	3-4
Check Clutch Torque Setting . . . . .	3-4
Torque Limiting Clutch Adjustment . . . . .	3-5
Drive Wheel Alignment - (Machines built prior to S/N-0130005271) . . . . .	3-5
3.5 DRIVE MOTOR ASSEMBLY - SERVICING . . . . .	3-6
Drive Motor Assembly - Removal . . . . .	3-6
Drive Motor Brake Removal and Adjustment . . . . .	3-11
Brake Operation . . . . .	3-12
Brake Assembly Removal . . . . .	3-12
Checking/Adjusting Armature Plate Gap Setting . . . . .	3-12
Brake Assembly Installation . . . . .	3-13
Drive Motor Boot Assembly Installation . . . . .	3-14
Drive Motor Brush Replacement . . . . .	3-15
Brush Cleaning and Inspection . . . . .	3-15
Brush Removal . . . . .	3-15
Brush Reassembly . . . . .	3-16
Gear Box Disassembly/Assembly . . . . .	3-17
Gear/Pinion Shaft Assembly . . . . .	3-18
Drive Shaft Assembly . . . . .	3-18
Final Gear Box Assembly . . . . .	3-19
3.6 POT HOLE PROTECTION SYSTEM . . . . .	3-20
3.7 BATTERY/BATTERY CHARGER - SERVICE PROCEDURES . . . . .	3-22
Battery Low Voltage Warning Indicators . . . . .	3-22
Diagnostics . . . . .	3-22
Battery Condition Testing . . . . .	3-22

Battery Replacement . . . . . 3-23  
 Battery Charger General Information . . . . . 3-23  
 Battery Charger Troubleshooting . . . . . 3-23  
 Battery Charge/Flash Code LED Indicator on Platform Control Console . . . . . 3-24  
 Battery Charging Status Indicators Mounted on Ground Control Station Cover . . . . . 3-24  
 Wet/VRLA Battery - Charging Profile Switch . . . . . 3-24  
 General Component Installation Notes . . . . . 3-25  
 Battery Charger Installation . . . . . 3-25  
 Cover Installation . . . . . 3-25  
 AC Line Fuse Installation . . . . . 3-25  
 Interlock Relay Installation . . . . . 3-26  
 Wet/VRLA Switch Installation . . . . . 3-26  
 Shunt Assembly Installation . . . . . 3-26  
 SCR Rectifier Installation (Either Side) . . . . . 3-26  
 Transformer Installation . . . . . 3-27  
 Printed Circuit Board Installation . . . . . 3-27  
 DC Circuit Breaker/Voltage Select Switch Installation . . . . . 3-27

**SECTION 4 - CONTROL COMPONENTS**

4.1 CONTROL COMPONENTS OVERVIEW . . . . . 4-1  
 4.2 CONTROLS COVER INSTALLATION . . . . . 4-2  
     Battery Cover Doors . . . . . 4-2  
     Center, Left and Right Lower Covers . . . . . 4-2  
 4.3 CONTROL COMPONENTS - INSTALLATION . . . . . 4-3  
     Ground Control Module . . . . . 4-3  
     Traction Control Module . . . . . 4-3  
     Platform Control Console Installation . . . . . 4-3  
     Battery Installation . . . . . 4-4  
     Horn Installation . . . . . 4-4  
     Alarm Installation . . . . . 4-4  
     Battery Installation (EE Spec Machines Only) . . . . . 4-5  
     Fuse Box - (EE Spec Machines Only) . . . . . 4-5  
     Master Disconnect Switch - (EE Spec Machines Only) . . . . . 4-5  
 4.4 GROUND CONTROL MODULE - SERVICE PROCEDURE . . . . . 4-7  
     Cover Removal/Installation . . . . . 4-8  
     Power Selector/EStop Switch Installation . . . . . 4-9  
 4.5 GROUND CONTROL MODULE - PROGRAMMING . . . . . 4-10  
     General . . . . . 4-10  
     Programming Levels . . . . . 4-10  
     Activating Programming Mode . . . . . 4-10  
     Entering Password . . . . . 4-11  
     Programming Mode Selection . . . . . 4-11  
     Selecting Programmable Item to Adjust . . . . . 4-11  
     Adjusting Programmable Setting . . . . . 4-11  
     Service Programming Mode - (Level-2) . . . . . 4-12  
     Operator Programming Mode - (Level-3) . . . . . 4-12  
 4.6 PLATFORM CONTROL CONSOLE - SERVICE PROCEDURES -  
 (MACHINES S/N - 0130007616 TO PRESENT) . . . . . 4-14  
     General . . . . . 4-14  
     Remove Platform Control Console . . . . . 4-14  
     Display/Controller Module Electrical Connections . . . . . 4-15  
     Mounting Bracket - Install/Remove . . . . . 4-15  
     Rear Cover - Install/Remove . . . . . 4-15  
     Display/Controller Module - Install/Remove . . . . . 4-16  
     Drive/Lift Mode Switch - Install/Remove . . . . . 4-16  
     Horn Button Switch - Install/Remove . . . . . 4-16

## TABLE OF CONTENTS

---

Key Switch - Install/Remove	4-16
E-Stop/ShutDown Switch - Install/Remove	4-17
Joystick Assembly - Install/Remove	4-17
4.7 PLATFORM CONTROL CONSOLE - SERVICE PROCEDURES - (MACHINES PRIOR TO S/N - 0130007616)	4-18
General	4-18
Remove Platform Control Console	4-18
Upper/Lower Shell Attach Screws	4-19
Emergency Stop Switch Installation	4-19
Upper/Lower Shell Component Connections	4-19
Button Pad Installation	4-19
Joystick Assembly Installation	4-20
Joystick Calibration Procedure	4-20
4.8 PUMP-MOTOR ASSEMBLY - SERVICE PROCEDURE	4-21
General	4-21
Inline Hydraulic Filter Installation	4-21
Pump/Motor/Tank Installation	4-21
Motor Cap/Motor Installation	4-22
Motor Brush Installation	4-22
Brush Housing Final Assembly Tips	4-23
Tank Installation	4-24
Pump Installation	4-24
Filter Screen Installation	4-24
Pressure Adjust Valve Installation	4-25
Pressure Check Valve Installation	4-25
4.9 OBSTRUCTION SENSOR SYSTEM - SERVICE PROCEDURE (DVSP - OPTION)	4-26
General	4-26
Transducer Sensor Check	4-27
OSS Component Installation	4-28

## SECTION 5 - MAST COMPONENTS

5.1 MAST COMPONENTS OVERVIEW	5-1
5.2 MAST CHAINS AND SEQUENCING CABLES ADJUSTMENT	5-2
Mast Chain/Cable Adjustment	5-2
Sequencing Cable Adjustment	5-2
5.3 SEQUENCE CABLE REPLACEMENT KIT	5-4
Remove Old Cable	5-4
Replacement Cable Installation	5-4
Clamp Installation (Drum/Socket Type)	5-4
5.4 HYDRAULIC LIFT CYLINDER - REMOVAL, INSPECTION AND REBUILD	5-7
Lift Cylinder Removal	5-7
Cylinder Disassembly	5-9
Lift Cylinder Component Inspection	5-9
Cylinder Assembly	5-10
Cylinder Installation	5-11
5.5 MAST ASSEMBLY INSTALLATION	5-12
Mast Removal	5-12
Mast Installation	5-12
5.6 MAST ASSEMBLY AND DISASSEMBLY PROCEDURES	5-13
Mast Disassembly Procedure	5-13
Mast Assembly - DVL/DVSP	5-16
5.7 DVSP - STOCKPICKER PLATFORM - INSTALLATION	5-24
5.8 DVSP - STOCKPICKER PLATFORM - MID-GATE INTERLOCK INSTALLATION	5-25
5.9 MAST BEACON - INSTALLATION	5-25



**SECTION 6 - TROUBLESHOOTING**

6.1 GENERAL . . . . . 6-1

6.2 TROUBLESHOOTING INFORMATION. . . . . 6-1

6.3 HYDRAULIC CIRCUIT CHECKS. . . . . 6-1

6.4 ELECTRICAL CIRCUIT CHECKS . . . . . 6-1

    General. . . . . 6-1

    Ground Control Module LCD Display . . . . . 6-2

6.5 TROUBLESHOOTING TABLES INDEX . . . . . 6-8

    Specifications For Various Components. . . . . 6-8

    Special Pin Extractor Tools For Electrical Connectors . . . . . 6-8

    Fault Code Troubleshooting Tables . . . . . 6-8

    Main Power Circuit Troubleshooting. . . . . 6-9

    Mast Troubleshooting . . . . . 6-9

    Hydraulic Leak Troubleshooting . . . . . 6-9

    Base Frame Components Troubleshooting . . . . . 6-9

    Drive System Troubleshooting . . . . . 6-9

6.6 SPECIFICATIONS FOR VARIOUS COMPONENTS. . . . . 6-10

6.7 SPECIAL PIN EXTRACTOR TOOLS FOR ELECTRICAL CONNECTORS . . . . . 6-10

6.8 FAULT CODE TROUBLESHOOTING TABLES . . . . . 6-11

    Machine in Drive Speed Cut-Back (Turtle) Mode All The Time . . . . . 6-11

    Obstruction Sensor System - Detection . . . . . 6-12

    Battery Voltage Low - Warning Level 3 - Three (3) LED/LCDs lit. . . . . 6-12

    Code 02 - Left PHP Bar - UP. . . . . 6-13

    Code 03 - Right PHP Bar - UP . . . . . 6-13

    Code 04 - Tilt Condition . . . . . 6-14

    Code 05 - Reserved . . . . . 6-14

    Code 06 - Reserved . . . . . 6-14

    Code 07- Left Drive Motor - Disconnected. . . . . 6-14

    Code 08 - Right Drive Motor - Disconnected . . . . . 6-15

    Code 09 - Left Brake - Disconnected . . . . . 6-15

    Code 10 - Right Brake - Disconnected. . . . . 6-15

    Code 11 - Left Drive Motor - Short Circuit . . . . . 6-16

    Code 12 - Right Drive Motor - Short Circuit . . . . . 6-16

    Code 13 - Traction Module - In Fold Back . . . . . 6-16

    Code 14 - Pump Motor - Disconnected . . . . . 6-17

    Code 15 - Lift Down Valve - Disconnected. . . . . 6-17

    Code 16 - Lift Down Valve - Short Circuit . . . . . 6-18

    Code 17 - Ground Control Module - In Fold Back. . . . . 6-18

    Code 18 - Alarm - Short Circuit. . . . . 6-18

    Code 19 - Alarm - Disconnected . . . . . 6-19

    Code 20 - Beacon - Short Circuit . . . . . 6-19

    Code 21 - Beacon - Disconnected . . . . . 6-20

    Code 22 - Horn - Short Circuit . . . . . 6-20

    Code 23 - Horn - Disconnected . . . . . 6-21

    Code 24 - Auxiliary #1 Circuit - Short Circuit . . . . . 6-21

    Code 25 - Auxiliary #1 Circuit - Disconnected. . . . . 6-22

    Code 26 - Auxiliary #2 - Short Circuit. . . . . 6-22

    Code 27 - Auxiliary #2 - Disconnected . . . . . 6-23

    Code 28 - Reserved . . . . . 6-23

    Code 29 - Reserved . . . . . 6-23

    Code 30 - Traction Module - No Communication with Ground Control Module. . . . . 6-24

    Code 31 - Platform Control Console - No Communication with Ground Control Module . 6-25

    Code 32 - Pump Motor - Over Current . . . . . 6-25

    Code 33 - Both PHP Bars - UP . . . . . 6-26

    Code 38 - Battery Voltage Low - Warning Level 2 - Two (2) LED/LCDs lit . . . . . 6-26

## TABLE OF CONTENTS

---

Code 39 - Battery Voltage Low - Warning Level 3 - One (1) LED/LCDs lit . . . . .	6-26
Code 40 - Obstruction Sensor System - No Communication with Ground Control Module	6-27
Codes 41 thru 46 - OSS - Sensor 1 through 6 - Fault Condition . . . . .	6-28
Codes (100 - 199) Ground Control Module - Fault Condition . . . . .	6-29
Codes (200 - 299) Platform Control Console - Fault Condition . . . . .	6-30
Codes (300 - 399) Traction Control Module - Fault Condition . . . . .	6-31
6.9 MAIN POWER CIRCUIT TROUBLESHOOTING . . . . .	6-32
Machine Will Not Power Up . . . . .	6-32
6.10 MAST TROUBLESHOOTING . . . . .	6-33
Platform Will Not Lower Manually . . . . .	6-33
Platform Lift Up And Down Jerky . . . . .	6-33
Mast Noisy When Lifting And Lowering . . . . .	6-34
Platform (Mast) Won't Stay Elevated . . . . .	6-35
Platform (Mast) Descends Too Slowly . . . . .	6-35
6.11 HYDRAULIC LEAK TROUBLESHOOTING . . . . .	6-36
Miscellaneous Hydraulic Leak Troubleshooting . . . . .	6-36
6.12 BASE FRAME COMPONENTS TROUBLESHOOTING . . . . .	6-37
Caster Wheels Not Operating Freely . . . . .	6-37
Pot Hole Protection (PHP) Bars will not Lower . . . . .	6-37
6.13 DRIVE SYSTEM TROUBLESHOOTING . . . . .	6-38
Won't Climb Grade . . . . .	6-38
Machine Drives in Opposite Direction . . . . .	6-39
Machine Won't Drive Straight . . . . .	6-40
Noise From Drive Assembly . . . . .	6-41

LIST OF FIGURES

FIGURE NO.	TITLE	PAGE NO.
1-1.	Hydraulic Pressure Adjustment Screw. (Machine Rear Covers Removed) . . . . .	1-3
1-2.	Typical Hydraulic Pressure Gauge Installation (Hydraulic Filter Removed) . . . . .	1-4
1-3.	Typical Hydraulic Pressure Gauge Installation (After Hydraulic Filter) . . . . .	1-4
1-4.	Torque Chart. (ANSI Spec.) . . . . .	1-6
1-5.	Torque Chart. (ANSI to METRIC Conversion) . . . . .	1-7
1-6.	Torque Chart (Metric Class Fasteners) . . . . .	1-8
2-1.	Accessing Machine Underside Components by Lifting with a Fork Truck. . . . .	2-9
3-1.	Base Components. . . . .	3-1
3-2.	Drive Motor Assembly Components. (Machines built <b>prior</b> to S/N-0130005271) . . . . .	3-7
3-3.	Drive Motor Assembly Components. (Machines built <b>since</b> S/N-0130005271) . . . . .	3-7
3-4.	Drive Motor Component Assembly (Machines built <b>prior</b> to S/N-0130005271) . . . . .	3-9
3-5.	Drive Motor Component Assembly (Machines built <b>since</b> S/N-0130005271) . . . . .	3-10
3-6.	Torque Limiting Clutch Assembly. . . . .	3-11
3-7.	Brake Assembly Components . . . . .	3-12
3-8.	Drive Motor Gear Box Assembly - DVL/DVSP. . . . .	3-17
3-9.	Pot-Hole-Protection System Components. . . . .	3-20
3-10.	DVL/DVSP - SCR Dual Voltage - Battery Charger Wiring Diagram. . . . .	3-28
4-1.	Control Components Location - DVL/DVSP. . . . .	4-1
4-2.	Component Electrical Connections. . . . .	4-6
4-3.	Ground Control Module Components. . . . .	4-7
4-4.	Platform Control Console Components. . . . .	4-14
4-5.	Platform Control Console Components. . . . .	4-18
5-1.	Mast Components. (DVL/DVSP) . . . . .	5-1
5-2.	DVL/DVSP - Mast Chain and Sequence Cable Adjustment Components. . . . .	5-3
5-3.	Machine Positioned for Cylinder Removal. . . . .	5-7
5-4.	Lift Cylinder Component Cross-Section (DVL/DVSP). . . . .	5-10
5-5.	Mast Section - Assembly Reference. . . . .	5-13
5-6.	Mast Chain Routing Diagram. - DVL/DVSP. . . . .	5-15
5-7.	Mast Bottom End - Slide Pad Installation (Typical) . . . . .	5-16
5-8.	Mast Top End - Slide Pad Installation (Typical) . . . . .	5-17
5-9.	DVSP - StockPicker Platform Installation. . . . .	5-24
6-1.	Component Electrical Connections. . . . .	6-3
6-2.	Overview of Electrical System Components. (DVL/DVSP) (Sheet 1 of 2) . . . . .	6-42
6-3.	Electrical Diagram. (DVL/DVSP) (Sheet 1) . . . . .	6-44
6-4.	Electrical Diagram - (with Load Sensing System) (DVL/DVSP) (Sheet 2) . . . . .	6-46
6-5.	Hydraulic Diagram. (DVL/DVSP) . . . . .	6-48

LIST OF TABLES

TABLE NO.	TITLE	PAGE NO.
1-1	DVL and DVSP - Machine Specifications . . . . .	1-1
1-2	Hydraulic Oil Operating Range . . . . .	1-3
1-3.	Lubrication Specifications . . . . .	1-3
1-4.	Cylinder Specifications . . . . .	1-4
1-5	Lubrication Intervals for Various Components . . . . .	1-5
2-1	Inspection and Maintenance. . . . .	2-2
2-2	DVL/DVSP - Preventive Maintenance & Inspection Schedule. . . . .	2-4
2-3	Chain Stretch Tolerance . . . . .	2-7
3-1	Battery Low Voltage Warning Indicators. . . . .	3-22
4-1	DVL/DVSP Ground Control Module - Field Programmable Settings and Factory Preset. . . . .	4-13
4-2	Obstruction Sensor System Components (Platform Cutaway) . . . . .	4-26
5-1	DVL/DVSP Mast Component Features . . . . .	5-13
6-1	LCD Display - Service Fault Code Conditions . . . . .	6-4

## TABLE OF CONTENTS

---

6-2	Ohm Ratings for Various Components . . . . .	6-10
6-3	Amperage Draw for Various Components . . . . .	6-10
6-4	Special Pin Extractor Tools for Electrical Connectors . . . . .	6-10
6-5	Machine In Drive Speed Cut-Back (Turtle) Mode All The Time . . . . .	6-11
6-6	Obstruction Sensor System - Detection . . . . .	6-12
6-7	Code 02 - Left PHP Bar - UP . . . . .	6-13
6-8	Code 03 - Right PHP Bar - UP . . . . .	6-13
6-9	Code 04 - Tilt Condition . . . . .	6-14
6-10	Code 07 - Left Drive Motor - Disconnected . . . . .	6-14
6-11	Code 08 - Right Drive Motor Disconnected . . . . .	6-15
6-12	Code 09 - Left Brake - Disconnected . . . . .	6-15
6-13	Code 10 - Right Brake - Disconnected . . . . .	6-15
6-14	Code 11 - Left Drive Motor - Short Circuit . . . . .	6-16
6-15	Code 12 - Right Drive Motor - Short Circuit . . . . .	6-16
6-16	Code 13 - Traction Module - In Fold Back . . . . .	6-16
6-17	Code 14 - Pump Motor - Disconnected . . . . .	6-17
6-18	Code 15 - Lift Down Valve - Disconnected . . . . .	6-17
6-19	Code 16 - Lift Down Valve - Short Circuit . . . . .	6-18
6-20	Code 17 - Ground Control Module - In Fold Back . . . . .	6-18
6-21	Code 18 - Alarm - Short Circuit . . . . .	6-18
6-22	Code 19 - Alarm - Disconnected . . . . .	6-19
6-23	Code 20 - Beacon - Short Circuit . . . . .	6-19
6-24	Code 21 - Beacon - Short Disconnected . . . . .	6-20
6-25	Code 22 - Horn - Short Circuit . . . . .	6-20
6-26	Code 23 - Horn - Disconnected . . . . .	6-21
6-27	Code 24 - Auxiliary #1 Circuit - Short Circuit . . . . .	6-21
6-28	Code 25 - Auxiliary #1 Circuit - Disconnected . . . . .	6-22
6-29	Code 26 - Auxiliary #2 - Short Circuit . . . . .	6-22
6-30	Code 27 - Auxiliary #2 - Disconnected . . . . .	6-23
6-31	Code 30 - Traction Module - No Communication with Ground Control Module . . . . .	6-24
6-32	Code 31 - Platform Control Console - No Communication with Ground Control Module . . . . .	6-25
6-33	Code 32 - Pump Motor - Over Current . . . . .	6-25
6-34	Code 33 - Both PHP Bars - UP . . . . .	6-26
6-35	Code 40 - OSS - No Communication with Ground Control Module . . . . .	6-27
6-36	Codes 41 thru 46 - OSS - Sensor 1 through 6 - Fault Condition . . . . .	6-28
6-37	Codes (100 - 199) Ground Control Module - Fault Condition . . . . .	6-29
6-38	Code (200 - 299) Platform Control Console - Fault Condition . . . . .	6-30
6-39	Codes (300 - 399) Traction Control Module - Fault Condition . . . . .	6-31
6-40	Machine Will Not Power UP . . . . .	6-32
6-41	Platform Will Not Lower Manually . . . . .	6-33
6-42	Platform Lift Up and Down Jerky . . . . .	6-33
6-43	Mast Noisy when Lifting and Lowering . . . . .	6-34
6-44	Platform (Mast) Won't Stay Elevated . . . . .	6-35
6-45	Platform (Mast) Descends Too Slowly . . . . .	6-35
6-46	Hydraulic Leak Troubleshooting . . . . .	6-36
6-47	Caster Wheels Not Operating Freely . . . . .	6-37
6-48	Pot Hole Protection (PHP) Bars will not Lower . . . . .	6-37
6-49	Won't Climb Grade . . . . .	6-38
6-50	Machine Drive in Opposite Direction . . . . .	6-39
6-51	Machine Won't Drive Straight . . . . .	6-40
6-52	Noise from Drive Assembly . . . . .	6-41

SECTION 1. MACHINE SPECIFICATIONS

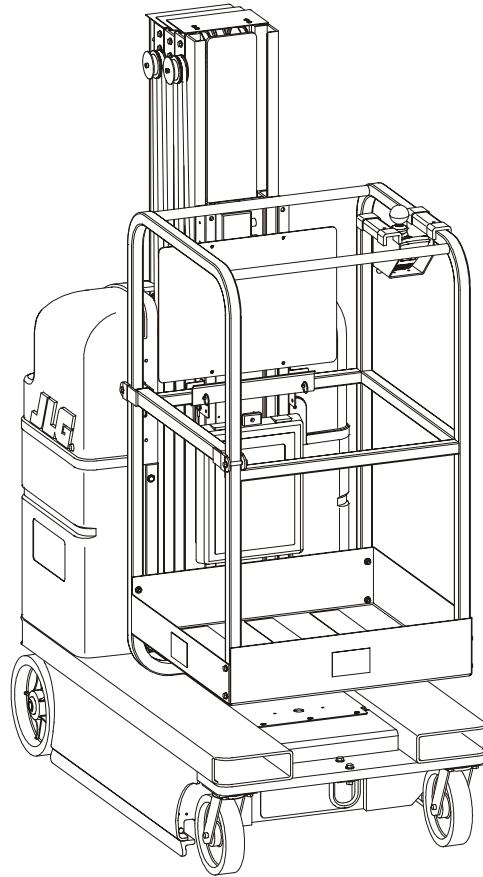

Table 1-1. DVL and DVSP - Machine Specifications

	15DVL	20DVL	15DVSP	20DVSP	
Maximum Occupants:	1				
Maximum Work Load (Capacity): (DVL-Std. Platform / DVSP - Stockpicker Platform)	500 lb. (230 kg)	350 lb. (160 kg)	500 lb. (230 kg)	400 lb. (180 kg)	
Maximum Travel Grade (Gradeability): (Platform STOWED ONLY)	20%				
Maximum Travel Grade (Side Slope): (Platform STOWED ONLY)	5°				
Maximum Vertical Platform Height:	15 ft. (4.57 m)	19.5 ft. (5.94 m)	15 ft. (4.57 m)	19.5 ft. (5.94m)	
Maximum Wheel Load (Per Wheel):	800 lb. (360 kg)				
Maximum Drive Speeds (Operator Variable):	0.5 - 2 mph (0.8 - 3.2 kph)				
Max. Platform Speeds (w/Max. Load):	Platform Up:	20 sec.	22.5 sec.	20 sec.	22.5 sec.
	Platform Down:	15 - 21 sec.	21 - 26 sec.	15 - 21 sec.	21 - 26 sec.
Gross Machine Weight (Platform Empty):	2,105 lb. (955 kg)	2,105 lb. (955 kg)	2,150 lb. (975 kg)	2,150 lb. (975kg)	

## SECTION 1 - MACHINE SPECIFICATIONS

---

---

### 1.1 CAPACITIES

#### System Voltage

---

All Models – 24 Volt DC

#### Hydraulic System

---

All Models – 5 qts. U.S. (4.7 L)

#### Drive Motor GearBox (gear oil)

---

All Models – 6 oz. (175cc)

---

### 1.2 COMPONENT DATA

#### Hydraulic Pump/Pump Motor Assembly

---

Pump Motor - 24 Volt DC motor, Standard Duty

Pump Displacement –

DVL/DVSP – .098 cu. in./rev. (1.6cc/rev.)

Pump Output (Max.) –

DVL/DVSP - 1.20 gpm @ 2200 psi @ 23.5 volts and 105  
amps @ 45 centistrokes (200 SSU)

Reservoir Capacity –

DVL/DVSP - 1 Gallon (3.78 L)

#### Rear Wheel Drive Motors

---

Drive Motors -

1/2 HP, 24 Volt DC, Variable

Right Angle, Sealed Gear Box, 40:1 ratio

Brake Shaft and Drive Shaft - Integral to Motor

Parking Brake (must be released for pushing)

#### Batteries/Battery Charger

---

Batteries (2) – 12 Volt / 100 Amp Hour –  
Deep Cycle Marine - RV

Weight – 65.7 lb. (29.8 Kg) - Per Battery

Battery Charger –

Microprocessor Controlled/SCR Circuit Monitor

120/240 Volt A.C. Selectable / 50/60 Hz input

24 volt, 20 amp output - with 2 amp finish

Reset Circuit Breaker

Automatic Charge Circuit

Plug Interlock Circuit

Wet/VRLA Battery Switch

**NOTE:** The batteries on DVL/DVSP machines require approximately five (5) hours to fully charge when drained to LOW BATTERY VOLTAGE warning on the Ground Control Module LCD display.

---

### 1.3 PERFORMANCE DATA

#### Platform Capacities

---

Standard - 15DVL - 500 lb. (230kg)

20DVL - 350 lb. (160kg)

StockPicker - 15DVSP - 500 lb. (230kg)

20DVSP - 400 lb. (180kg)

Extendible - 15DVL/ 15DVSP - 500 lb. (230kg)

20DVL Series - 350 lb. (160kg)

Molded - 15DVL/15DVSP - 500 lb. (230kg)

20DVL Series - 350 lb. (160kg)

**NOTE:** Distribute weight evenly in platform when loading. Reference the capacity decal on the machines' decal billboard mounted on mast.

#### Platform Size

---

Standard - 26in.-W x 26 in.-L (66cm) x (66cm)

Stockpicker - 28in.-W x 48in.-L (71cm x 122cm)

Extendible - 26in.-W x 49in.-L (66cm x 124cm)

Moulded - 25in.-W x 26in.-L (64cm x 66cm)

#### Machine Height (platform stowed)

---

DVL/DVSP - 78 in. (198cm) height

#### Base Footprint

---

DVL/DVSP - 29.25in.-W x 52in.-L (74cm) x (132cm)

---

### 1.4 TORQUE REQUIREMENTS

When maintenance becomes necessary or a fastener has loosened, refer to the applicable Torque Chart in this section of the manual, to determine proper torque values.

1.5 LUBRICATION

Hydraulic Oil

Hydraulic oils must have anti-wear qualities at least to API Service Classification GL-3, and sufficient chemical stability for mobile hydraulic system service. JLG Industries, recommends Mobilfluid 424 hydraulic oil, which has an SAE viscosity of 10W-30 and a viscosity index of 152.

For cold weather applications, i.e. when temperatures remain consistently below +20°F (-7°C) JLG recommends using Mobil DTE 13 hydraulic oil.

Aside from JLG recommendations, it is not advisable to mix oils of different brands or types, as they may not contain the same required additives or be of comparable viscosities. If use of hydraulic oil other than Mobilfluid 424 is desired, contact JLG Industries for proper recommendations.

Table 1-2. Hydraulic Oil Operating Range

HYDRAULIC SYSTEM OPERATING TEMPERATURE RANGE	SAE VISCOSITY GRADE
+0° F to +180° F (-18° C to +83° C)	10W
+0° F to +210° F (-18° C to +99° C)	10W-20, 10W-30
+50° F to +210° F (+10° C to +99° C)	20W-20

Lubrication Specifications

Table 1-3. Lubrication Specifications

KEY	SPECIFICATIONS
MPG -	Multipurpose Grease having a minimum dripping point of 350° F. Excellent water resistance and adhesive qualities, and being of extreme pressure type. (Timken OK 40 pounds minimum.)
EPGL -	Extreme Pressure Gear Lube (oil) meeting API service classification GL-5 or MIL-Spec MIL-L-2105.
HO -	Hydraulic Oil. ISO-Vg grade 32, 46.
CL -	Chain Lube. Use a good quality chain lubricant.

1.6 HYDRAULIC PRESSURE SETTINGS AND ADJUSTMENT

Adjust system pressure so that platform will raise with maximum rated capacity in platform.

The following pressure setting are factory recommended (initial) settings;

MODEL	PRESSURE SETTING
15DVL/15DVSP	2600 PSI
20DVL	1800 PSI
20DVSP	2800 PSI

Turning adjustment screw **clockwise increases system pressure**, turning screw **counterclockwise decreases system pressure**. (See Figure 1-1., Hydraulic Pressure Adjustment Screw. (Machine Rear Covers Removed))

Perform pressure adjustment with oil at normal operating temperature. If pressure is set when oil is cold, platform may not raise rated load after soil has warmed.

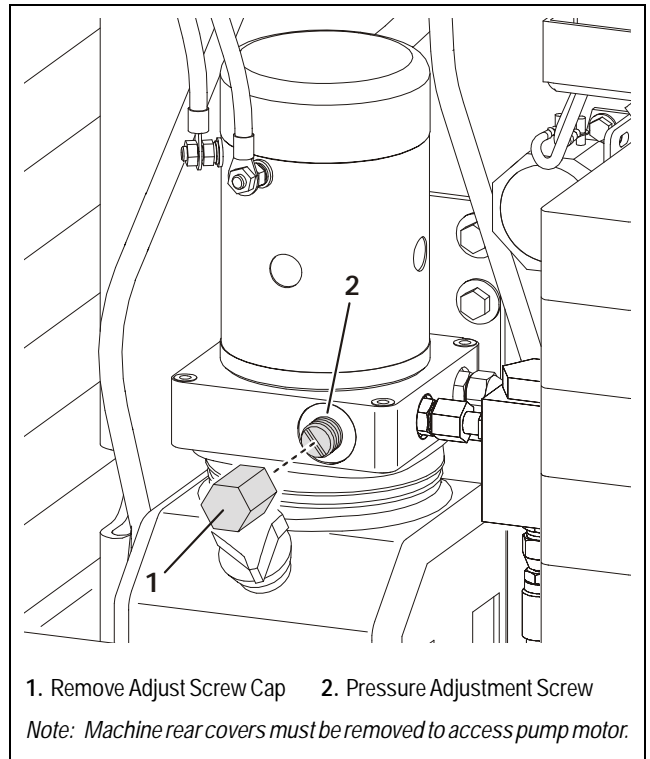

1. Remove Adjust Screw Cap 2. Pressure Adjustment Screw

Note: Machine rear covers must be removed to access pump motor.

Figure 1-1. Hydraulic Pressure Adjustment Screw. (Machine Rear Covers Removed)

## SECTION 1 - MACHINE SPECIFICATIONS

### Hydraulic Pressure Gauge Connection

#### **CAUTION**

ONLY OPEN HYDRAULIC SYSTEM LINES WITH THE MAST FULLY LOWERED TO RELIEVE PRESSURE IN THE SYSTEM. CAREFULLY LOOSEN REQUIRED FITTINGS, WEAR SAFETY PROTECTION EQUIPMENT WHEN WORKING WITH HYDRAULIC SYSTEMS.

Remove the hydraulic oil filter and install a t-fitting between the pump and the extend line to connect a hydraulic pressure gauge as shown in Figure 1-2., Typical Hydraulic Pressure Gauge Installation (Hydraulic Filter Removed).

CHECK, and if necessary, ADJUST the hydraulic pressure to initial settings shown in table at the beginning of this section. Cycle the hydraulic system several times with the maximum load capacity in the platform, then recheck pressure setting. When pressure has stabilized continue to "After Filter Pressure Check" following.

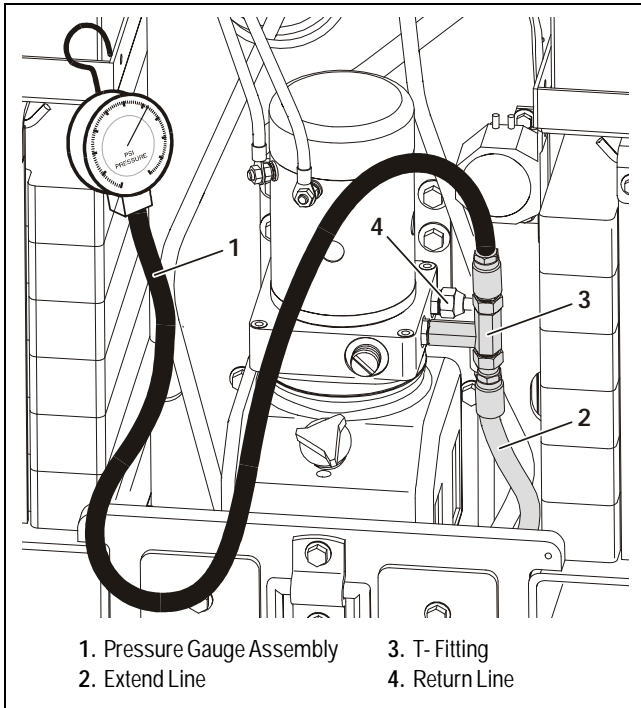

Figure 1-2. Typical Hydraulic Pressure Gauge Installation (Hydraulic Filter Removed).

#### After Filter Pressure Check

Reinstall the hydraulic oil filter and install the t-fitting between the hydraulic filter and the extend line to the cylinder. Recheck the hydraulic pressure and compare with the previous readings when filter was removed. If a significant drop in pressure reading has occurred, replace the hydraulic filter and recheck the "after filter" pressure reading.

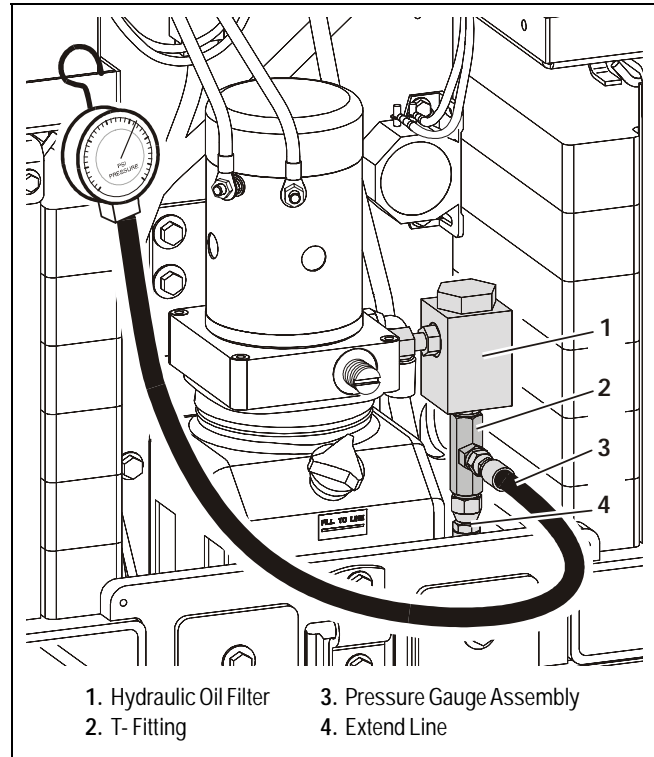

Figure 1-3. Typical Hydraulic Pressure Gauge Installation (After Hydraulic Filter).

## 1.7 CYLINDER SPECIFICATIONS

**NOTE:** All dimensions are given in inches (in), with the metric equivalent, centimeters (cm), given in parentheses.

Table 1-4. Cylinder Specifications

DESCRIPTION	BORE in./(cm)	STROKE in./(cm)	ROD DIA. in./(cm)
15DVL/15DVSP - Lift Cylinder	1.63 (4.10)	41.50 (105.4)	1.375 (3.49)
20DVL/20DVSP - Lift Cylinder	1.63 (4.10)	54.0 (137.1)	1.375 (3.49)

## 1.8 SERIAL NUMBER LOCATIONS

For machine identification, a serial number plate is affixed to the machine. The plate is located on the back of the mast, just above the mast support column.



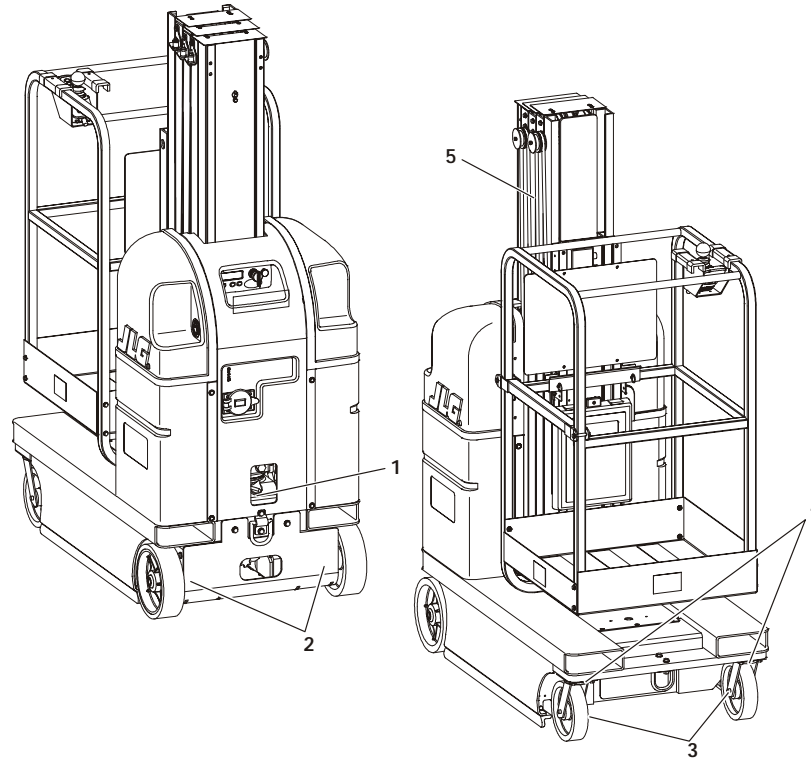

Table 1-5. Lubrication Intervals for Various Components

ITEM	COMPONENT	NO/TYPE (a) LUBE POINTS	LUBE/METHOD	INTERVAL (b)				COMMENTS
				3 MONTHS	6 MONTHS	1 YEAR	2 YEARS	
1	Hydraulic Oil	Fill To Line on Reservoir 5 Qt. Reservoir	HO - Check Hyd. Oil Level HO - Change Hyd. Oil				✓	Check fluid level every day. (c) Change hydraulic oil every 2 years.
2	Drive Wheel Bearings	—	—					Permanently Sealed.
3	Drive Wheel Gear Box	2 - Gear Boxes	Gear Oil					Change only when serviced requires 6 oz. (175 cc's) to fill.
4	Caster Axles	2 - Grease Fittings	MPG - Pressure Gun	✓				
5	Swivel Raceways	2 - Front Casters	MPG - Pressure Gun	✓				
6	Mast Chains	2 - Per Section	Chain Lube - Brush or Spray		✓			Inspect, lubricate if dry or rusting.
Key to Lubricants: <b>MPG</b> - Multipurpose Grease <b>HO</b> - Hydraulic Oil - ISO-Vg grade 32, 46. <b>GEAR OIL</b> - Good Quality Worm Gear Oil - SAE 90 - AGMA#5 - EP Compounded <b>CL</b> - Chain Lube. Use a good quality chain lubricant								
Notes: (a) Be certain to lubricate like items on each side of the machine. (b) Recommended lubricating intervals are based on normal use. If machine is subjected to severe operating conditions, such as a high number of cycles, location, corrosive/dirty environment, etc., user must adjust lubricating requirements accordingly. (c) Prior to checking hydraulic oil level, operate machine through one complete cycle of lift function (full up and down). Failure to do so will result in incorrect oil level reading on the hydraulic reservoir.								

SECTION 1 - MACHINE SPECIFICATIONS

SIZE	THD	BOLT DIA. (IN.)	THREAD STRESS AREA (SQ. IN.)	VALUES FOR ZINC PLATED BOLTS ONLY												UNPLATED CAP SCREWS		
				SAE GRADE 5 BOLTS & GRADE 2 NUTS				SAE GRADE 8 BOLTS & GRADE 8 NUTS				UNBRAKO 1960 SERIES SOCKET HEAD CAP SCREW WITH LOC-WEL PATCH						
				CLAMP LOAD (LB.)		TORQUE (UUB.)		CLAMP LOAD (LB.)		TORQUE (UUB.)		CLAMP LOAD (LB.)		TORQUE (UUB.)			CLAMP LOAD (LB.)	
				(DRY OR LOC. 263) LB. IN.	(LOCTITE 262) LB. IN.	(DRY OR LOC. 263) LB. IN.	(LOCTITE 262) LB. IN.	(DRY OR LOC. 263) LB. IN.	(LOCTITE 262) LB. IN.	(DRY OR LOC. 263) LB. IN.	(LOCTITE 262) LB. IN.	(DRY OR LOC. 263) LB. IN.	(LOCTITE 262) LB. IN.	(DRY OR LOC. 263) LB. IN.	(LOCTITE 262) LB. IN.		(DRY OR LOC. 263) LB. IN.	(LOCTITE 262) LB. IN.
4	40	0.1120	0.00604	380	8	6	—	—	—	540	12	9	—	—	—	—	—	
	48	0.00661	0.00909	420	9	7	—	—	600	13	10	—	—	—	—	—	—	
6	32	0.1380	0.01015	580	16	12	—	—	820	23	17	—	—	—	—	—	—	
	40	0.01400	0.01474	610	18	13	—	—	920	25	19	—	—	—	—	—	—	
8	32	0.1640	0.01750	900	30	22	—	—	1260	41	31	—	—	—	—	—	—	
	36	0.02000	0.02000	940	31	23	—	—	1320	43	32	—	—	—	—	—	—	
10	24	0.1900	0.0318	1120	43	32	—	—	1580	60	45	—	—	—	—	—	—	
	32	0.0364	0.0364	1285	49	36	—	—	1800	68	51	—	—	—	—	—	—	
1/4	20	0.2500	0.0524	2020	96	75	—	105	2860	144	108	—	—	160	3180	13	—	
	28	0.0580	0.0580	2320	120	86	—	135	3280	168	120	—	—	185	3640	14	—	
	18	0.3125	0.0775	3340	17	13	16	19	4720	25	18	22	30	5240	25	—	—	
	24	0.0878	0.1063	3700	19	14	17	21	5220	25	20	25	30	5800	27	—	—	
3/8	16	0.3750	0.1187	4940	30	23	28	35	7000	45	35	40	50	7750	45	—	—	
	24	0.4375	0.1599	5600	35	25	32	40	7900	50	35	45	55	8780	50	—	—	
7/16	14	0.5000	0.2030	6800	35	25	32	40	9550	70	55	63	80	10630	70	—	—	
	20	0.5625	0.2560	7550	55	40	50	60	10700	80	60	70	90	11870	75	—	—	
1/2	13	0.7500	0.3340	9050	75	55	68	85	12750	110	80	96	120	14190	110	—	—	
	20	0.8750	0.4620	10700	90	65	80	100	14400	120	90	108	135	15990	115	—	—	
9/16	12	0.9690	0.6060	11600	110	80	98	120	16400	150	110	139	165	18200	155	—	—	
	18	1.1250	0.8560	12950	120	90	109	135	18250	170	130	154	190	20300	165	—	—	
5/8	11	0.6250	0.2260	14400	150	110	135	165	20350	220	170	180	240	22600	210	—	—	
	18	0.7500	0.3730	16300	170	130	153	190	23000	240	180	204	265	25600	220	—	—	
3/4	10	0.7500	0.4620	21300	260	200	240	285	30100	380	280	301	420	33400	365	—	—	
	16	0.8750	0.6060	23800	300	220	268	330	33600	420	320	336	465	37300	400	—	—	
7/8	9	0.8750	0.5090	29400	430	320	386	475	41600	600	460	485	660	46200	585	—	—	
	14	1.0000	0.6630	32400	470	350	425	520	45800	660	500	534	725	50900	635	—	—	
1	8	1.0000	0.6630	38600	640	480	579	675	51500	900	680	687	990	60600	865	—	—	
	12	1.1250	0.8560	42200	700	530	633	735	59700	1000	740	796	1100	66300	915	—	—	
1-1/8	7	1.2500	0.7630	42300	800	600	714	840	68700	1280	960	1030	1400	76300	1240	—	—	
	12	1.5000	0.9690	47500	880	660	802	925	77000	1440	1080	1155	1575	85600	1380	—	—	
1-1/4	7	1.5000	1.0730	53800	1120	840	1009	1175	87200	1820	1360	1453	2000	96900	1750	—	—	
	12	1.7500	1.1550	59600	1240	920	1118	1300	96600	2000	1500	1610	2200	107300	1880	—	—	
1-1/2	6	1.5000	1.3150	64100	1460	1100	1322	1525	104000	2380	1780	1907	2625	115500	2320	—	—	
	12	1.7500	1.4050	73000	1680	1260	1506	1750	118100	2720	2040	2165	3000	131500	2440	—	—	
1-1/2	6	1.5000	1.5800	78000	1940	1460	1755	2025	126500	3160	2360	2530	3475	140500	3040	—	—	
	12	1.7500	1.7500	87700	2200	1640	1974	2300	142200	3560	2660	2844	3925	158000	3270	—	—	

Note: These torque values do not apply to cadmium plated fasteners.



SAE GRADE 5



SAE GRADE 8

SIZE	THD	BOLT DIA. (CM)	THREAD STRESS AREA (SQ. CM)	VALUES FOR ZINC PLATED BOLTS ONLY												UNPLATED CAP SCREWS	
				SAE GRADE 5 BOLTS & GRADE 2 NUTS				SAE GRADE 8 BOLTS & GRADE 8 NUTS				UNBRAKO 1960 SERIES SOCKET HEAD CAP SCREW WITH LOC-WEL PATCH					
				CLAMP LOAD (KG)		TORQUE (LUB.)		TORQUE (LOCTITE 262)		CLAMP LOAD (KG)		TORQUE (LUB.)		TORQUE (LOCTITE 242 OR 271)		CLAMP LOAD (KG)	TORQUE (as received) NM
(DRY OR LOC. 263) NM	(LUB.) NM	(LUB.) NM	(LOCTITE 262) NM	(DRY OR LOC. 263) NM	(LUB.) NM	(LUB.) NM	(LOCTITE 242 OR 271) NM	(DRY OR LOC. 263) NM	(LUB.) NM	(LUB.) NM	(LOCTITE 242 OR 271) NM	(KG)	(NM)				
4	40	0.2845	0.0153	172	1	1	—	—	245	2	—	—	—	—			
	48	0.0168	0.0168	191	1	1	—	—	272	2	—	—	—	—			
6	32	0.3505	0.0232	263	2	2	—	—	372	3	—	—	—	—			
	40	0.0258	0.0258	277	2	2	—	—	417	3	—	—	—	—			
8	32	0.4166	0.0356	408	4	3	—	—	572	5	—	—	—	—			
	36	0.0374	0.0374	426	4	3	—	—	599	5	—	—	—	—			
10	24	0.4826	0.0445	508	5	4	—	—	717	7	—	—	—	—			
	32	0.0508	0.0508	583	6	4	—	—	817	8	—	—	—	—			
1/4	20	0.6350	0.0808	916	11	9	—	12	1297	16	—	18	1442	18			
	28	0.0925	0.0925	1052	14	10	—	16	1488	19	—	21	1651	19			
5/16	18	0.7938	0.1331	1515	23	18	22	26	2141	34	25	30	2377	34			
	24	0.1473	0.1473	1678	26	19	23	29	2821	34	27	34	2631	37			
3/8	16	0.9525	0.1969	2241	41	31	38	48	3175	61	48	54	3493	61			
	24	0.2230	0.2230	2540	48	34	43	54	3583	68	48	61	3983	68			
7/16	14	1.1112	0.2700	3085	68	48	61	75	4332	95	75	85	4822	95			
	20	0.3015	0.3015	3425	75	68	68	81	4854	109	81	95	5384	102			
1/2	13	1.2700	0.3604	4105	102	75	92	115	5783	149	109	130	6437	149			
	20	0.4061	0.4061	4854	122	88	108	136	6532	163	122	146	7253	156			
9/16	12	1.4288	0.4623	5262	149	109	133	163	7539	204	149	188	8256	210			
	18	0.5156	0.5156	5874	163	122	148	183	8278	231	176	209	9208	224			
5/8	11	1.5875	0.5740	6532	204	149	183	224	9231	298	231	244	10251	285			
	18	0.6502	0.6502	7394	231	176	207	258	10433	326	244	277	11612	298			
3/4	10	1.9050	0.8484	9662	353	271	325	387	13653	515	380	408	15150	495			
	16	0.9474	0.9474	10796	407	298	363	448	15241	570	434	456	16919	542			
7/8	9	2.2225	1.1735	13336	583	434	523	644	18870	814	624	658	20956	793			
	14	1.2929	1.2929	14697	637	475	576	705	20775	895	678	724	23088	861			
1	8	2.5400	1.5392	17509	868	651	785	915	23360	1220	922	931	27488	1173			
	12	1.6840	1.6840	19142	949	719	858	997	27080	1356	1003	1079	30074	1241			
1-1/8	7	2.8575	1.9380	19187	1085	814	968	1139	31162	1736	1302	1396	34610	1681			
	12	2.1742	2.1742	21546	1193	895	1087	1254	34927	1953	1464	1566	38828	1871			
1-1/4	7	3.1750	2.4613	24404	1519	1139	1368	1593	38554	2468	1844	1970	43954	2373			
	12	2.7254	2.7254	27035	1681	1247	1516	1762	43818	2712	2034	2183	48671	2549			
1-1/2	6	3.4925	2.9337	29076	1980	1492	1792	2068	47174	3227	2413	2586	52391	3145			
	12	3.3401	3.3401	33113	2278	1708	2042	2373	53570	3688	2766	2935	59648	3308			
1-1/2	6	3.8100	3.5687	35381	2630	1980	2379	2746	57380	4284	3200	3430	63731	4122			
	12	4.0132	4.0132	39781	2983	2224	2676	3118	142200	4827	3607	3856	71669	4433			

Note: These torque values do not apply to cadmium plated fasteners.



SAE GRADE 5



SAE GRADE 8

**SECTION 1 - MACHINE SPECIFICATIONS**

VALUES FOR ZINC PLATED / YELLOW CHROMATE FASTENERS ONLY												
	CLASS 8.8 METRIC BOLTS & CLASS 8 METRIC NUTS							CLASS 10.9 METRIC BOLTS & CLASS 10 METRIC NUTS				
SIZE	PITCH	TENSILE STRESS AREA	CLAMP LOAD	TORQUE				CLAMP LOAD	TORQUE			
				DRY OR LOCTITE 263	LUB	LOCTITE 262	LOCTITE 242 OR 271		DRY OR LOCTITE 263	LUB	LOCTITE 262	LOCTITE 242 OR 271
		sq. mm	KN	N, m	N, m	N, m	N, m	KN	N, m	N, m	N, m	N, m
3	.5	5.03	2.19	1.3	1.0	1.2	1.4	3.13	1.9	1.4	1.5	2.1
3.5	.6	6.78	2.95	2.1	1.6	1.9	2.3	4.22	3.0	2.2	2.4	3.3
4	.7	8.78	3.82	3.1	2.3	2.8	3.4	5.47	4.4	3.3	3.5	4.8
5	.8	14.2	6.18	6.2	4.6	5.6	6.8	8.85	8.9	6.6	7.1	9.7
6	1	20.1	8.74	11	7.9	9.4	12	12.5	15	11	12	17
7	1	28.9	12.6	18	13	16	19	18	25	19	20	28
8	1.25	36.6	15.9	25	19	23	28	22.8	37	27	29	40
10	1.5	58.0	25.2	50	38	45	55	36.1	72	54	58	79
12	1.75	84.3	36.7	88	66	79	97	52.5	126	95	101	139
14	2	115	50.0	140	105	126	154	71.6	200	150	160	220
16	2	157	68.3	219	164	197	241	97.8	313	235	250	344
18	2.5	192	83.5	301	226	271	331	119.5	430	323	344	473
20	2.5	245	106.5	426	320	383	469	152.5	610	458	488	671
22	2.5	303	132.0	581	436	523	639	189.0	832	624	665	915
24	3	353	153.5	737	553	663	811	220.0	1060	792	845	1170
27	3	459	199.5	1080	810	970	1130	286.0	1540	1160	1240	1690
30	3.5	561	244.0	1460	1100	1320	1530	349.5	2100	1570	1680	2310
33	3.5	694	302.0	1990	1490	1790	2090	432.5	2600	2140	2280	2860
36	4	817	355.0	2560	1920	2300	2690	509.0	3660	2750	2930	4020
42	4.5	1120	487.0	4090	3070	3680	4290	698.0	5860	4400	4690	6440

Note: These torque values do not apply to cadmium plated fasteners.



METRIC CLASS 8.8



METRIC CLASS 10.9

Figure 1-6. Torque Chart (Metric Class Fasteners)

## SECTION 2. GENERAL

### 2.1 MACHINE PREPARATION, INSPECTION, AND MAINTENANCE

#### General

This section provides the necessary information needed by those personnel that are responsible to place the machine in operation readiness and maintain its safe operating condition. For maximum service life and safe operation, ensure that all the necessary inspections and maintenance have been completed before placing the machine into service.

#### Preparation, Inspection, and Maintenance

It is important to establish and conform to a comprehensive inspection and preventive maintenance program. The following table outlines the periodic machine inspections and maintenance recommended by JLG Industries, Inc. Consult your national, regional, or local regulations for further requirements for aerial work platforms. The frequency of inspections and maintenance must be increased as environment, severity and frequency of usage requires.

#### Pre-Start Inspection

It is the User's or Operator's primary responsibility to perform a Pre-Start Inspection of the machine prior to use daily or at each change of operator. Reference the Operator's and Safety Manual for completion procedures for the Pre-Start Inspection. The Operator and Safety Manual must be read in its entirety and understood prior to performing the Pre-Start Inspection.

#### Pre-Delivery Inspection and Frequent Inspection

The Pre-Delivery Inspection and Frequent Inspection shall be performed by a qualified JLG equipment mechanic. JLG Industries, Inc. recognizes a qualified JLG equipment mechanic as a person who, by possession of a recognized degree, certificate, extensive knowledge, training, or experience, has successfully demonstrated the ability and proficiency to service, repair, and maintain the subject JLG product model.

The Pre-Delivery Inspection and Frequent Inspection procedures are performed in the same manner, but at different times. The Pre-Delivery Inspection shall be performed prior to each sale, lease, or rental delivery. The Frequent Inspection shall be accomplished for each machine in service for 3 months; out of service for a period of more than 3 months; or when purchased used. The frequency of this inspection must be increased as environment, severity and frequency of usage requires.

Reference the JLG Pre-Delivery and Frequent Inspection Form and the Inspection and Preventative Maintenance Schedule for items requiring inspection during the performance of these inspections. Reference the appropriate areas of this manual for servicing and maintenance procedures.

#### Annual Machine Inspection

The Annual Machine Inspection must be performed by a qualified JLG equipment mechanic on an annual basis, no later than thirteen (13) months from the date of the prior Annual Machine Inspection. JLG Industries, Inc. recognizes a qualified JLG equipment mechanic as a person who has successfully completed the JLG Service Training School for the subject JLG product model. Reference the machine Service and Maintenance Manual and appropriate JLG inspection form for performance of this inspection.

Reference the JLG Annual Machine Inspection Form and the Inspection and Preventative Maintenance Schedule for items requiring inspection during the performance of this inspection. Reference the appropriate areas of this manual for servicing and maintenance procedures.

For the purpose of receiving safety-related bulletins, it is important that JLG Industries, Inc. has updated ownership information for each machine. When performing each Annual Machine Inspection, notify JLG Industries, Inc. of the current machine ownership.

#### Preventative Maintenance

In conjunction with the specified inspections, maintenance shall be performed by a qualified JLG equipment mechanic. JLG Industries, Inc. recognizes a qualified JLG equipment mechanic as a person who, by possession of a recognized degree, certificate, extensive knowledge, training, or experience, has successfully demonstrated the ability and proficiency to service, repair, and maintain the subject JLG product model.

Reference Table 2-2, DVL/DVSP - Preventive Maintenance & Inspection Schedule., and the appropriate areas of this manual for servicing and maintenance procedures. The frequency of service and maintenance must be increased as environment, severity and frequency of usage requires.

## SECTION 2 - GENERAL

---

**Table 2-1. Inspection and Maintenance**

Type	Frequency	Primary Responsibility	Service Qualification	Reference
Pre-Start Inspection	Prior to use each day; or At each Operator change.	User or Operator	User or Operator	Operator and Safety Manual
Pre-Delivery Inspection	Prior to each sale, lease, or rental delivery.	Owner, Dealer, or User	Qualified JLG Mechanic	Service and Maintenance Manual and applicable JLG inspection form.
Frequent Inspection	In service for 3 months; or Out of service for a period of more than 3 months; or Purchased used.	Owner, Dealer, or User	Qualified JLG Mechanic	Service and Maintenance Manual and applicable JLG inspection form.
Annual Machine Inspection	Annually, no later than 13 months from the date of the prior inspection.	Owner, Dealer, or User	Qualified JLG Mechanic	Service and Maintenance Manual and applicable JLG inspection form.
Preventative Maintenance	At intervals as specified in the Service and Maintenance Manual.	Owner, Dealer, or User	Qualified JLG Mechanic	Service and Maintenance Manual

---

## 2.2 PREVENTIVE MAINTENANCE AND INSPECTION SCHEDULE

*(See Table 2-2.)*

The preventive maintenance and inspection checks are listed and defined in the following table. This table is divided into two basic parts, the "AREA" to be inspected and the "INTERVAL" at which the inspection is to take place. Under the "AREA" portion of the table, the various systems along with the components that make up that system are listed. The "INTERVAL" portion of the table is divided into five columns representing the various inspection time periods. The numbers listed within the interval column represent the applicable inspection code for which that component is to be checked.

The checks and services listed in this schedule are not intended to replace any local or regional regulations that may pertain to this type of equipment nor should the lists be considered as all inclusive. Variances in interval times may occur due to climate and/or conditions and depending on the location and use of the machine.

**SECTION 2 - GENERAL**

**Table 2-2. DVL/DVSP - Preventive Maintenance & Inspection Schedule.**

AREA ON MACHINE	INTERVAL				
	PRE-START (a) INSPECTION	3 MONTH PREVENTATIVE MAINTENANCE	6 MONTH PREVENTATIVE MAINTENANCE	PRE-DELIVERY (b) OR FREQUENT (c) INSPECTION	ANNUAL (d) (YEARLY) INSPECTION
<b>MAST ASSEMBLY</b>	7				
Mast Sections				2,5	2,5
Chain Systems			14	3,14	14,25
Sequence Cable Systems				3	1,2,3
Covers or Shields					1
Sheave Systems				1,2	1,2
Bearings					1,2
Slide Pads					1,2
<b>PLATFORM ASSEMBLY</b>	7				
Platform				1	1
Guard Rails				1,2,4	1,2,4
Gate				1,5	1,5
Floor				1,2	1,2
Extension Deck Assembly				1,5	1,5
Lanyard Anchorage Point				1,4	1,4
<b>CHASSIS ASSEMBLY</b>	7				
Pot Hole Protection System				5	5
Battery and Valve Covers or Doors				1,7	1,7
Static Strap					
Caster Wheels	1,2	14		1,2	1,2
Drive Wheels/Axle Assembly				2	2
Gear Box Assembly *					
Drive Motor Brushes					2,20
Torque Limit Clutch **				1,7	3
Brake Release				5	5
<b>FUNCTIONS/CONTROLS</b>	7				
Platform Controls				5,6,7	5,6,7
Ground Controls				5,6	5,6,14
Function Control Locks, Guards, or Detents				5	5
Function Enable System					
Emergency Stop Switches (Ground & Platform)					5
Function Limit or Cutout Switch Systems				5	
Drive Brakes					5
Manual Descent or Auxiliary Power				5	5
<b>POWER SYSTEM</b>					
Batteries	19			9	18
Battery Charger					5
<b>HYDRAULIC/ELECTRIC SYSTEM</b>	9				
Hydraulic Pump				1,2,9	1,2,5,9
Hydraulic Cylinder				2,7,9	2,9
Cylinder Attachment Pins and Pin Retainers				1,2	1,2
Hydraulic Hoses, Lines, and Fittings				1,9	1,9
Hydraulic Reservoir, Cap, and Breather				5,7	5,7



Table 2-2. DVL/DVSP - Preventive Maintenance &amp; Inspection Schedule. (Continued)

AREA ON MACHINE	INTERVAL				
	PRE-START (a) INSPECTION	3 MONTH PREVENTATIVE MAINTENANCE	6 MONTH PREVENTATIVE MAINTENANCE	PRE-DELIVERY (b) OR FREQUENT (c) INSPECTION	ANNUAL (d) (YEARLY) INSPECTION
Hydraulic Filter					
Hydraulic Fluid ***	11			11	11
Electrical Connections				20	20
Instruments, Gauges, Switches, Lights, Horn	5				
<b>GENERAL</b>					
Operator and Safety Manuals in Storage Box	21			21	21
ANSI and EMI Manuals/Handbooks Installed	21			21	21
Capacity Decals Installed, Secure, Legible	21			21	21
All Decals/Placards Installed, Secure, Legible	21			21	21
"Walk-Around" Inspection Performed	22				
Annual Machine Inspection Due				21	
No Unauthorized Modifications or Additions				21	21
All Relevant Safety Publications Incorporated				21	21, 22
General Structural Condition and Welds				2, 4	2, 4
All Fasteners, Pins, Shields, and Covers					1, 2
Grease and Lubricate to Specifications				22	22
Function Test of All Systems	22			22	
Paint and Appearance				7	7
Stamp Inspection Date on Frame					22
Notify JLG of Machine Ownership					22

\* Change only when serviced, requires 6 oz. (175cc's) to fill.

\*\* If the lift is moved via fork truck on a regular or frequent basis, then the torque setting should be checked every 3 months per Section 3 (of this manual) - Drive Motor Component Servicing.

\*\*\* Drain and refill with fresh hydraulic fluid every two years.

### Inspection and Maintenance Codes:

1. Check for proper and secure installation.
2. Visual inspection for damage, cracks, distortion, or excessive wear.
3. Check for proper adjustment.
4. Check for cracked or broken welds.
5. Operates properly.
6. Returns to neutral or "off" position when released.
7. Clean and free of debris.
8. Interlocks function properly.
9. Check for signs of leakage.
10. Decals installed and legible.
11. Check for proper fluid level.
12. Check for chafing and proper routing.
13. Check for proper tolerances.
14. Properly lubricated.
15. Torqued to proper specification.
16. No gouges, excessive wear, or cords showing.
17. Properly inflated and seated around rim.
18. Proper and authorized components.
19. Fully charged.
20. No loose connections, corrosion, or abrasions.
21. Verify.
22. Perform.
23. Sealed properly.
24. Overrides Platform controls.
25. Inspected per Service and Maintenance Manual.

### Footnotes:

- (a) Prior to use each day; or at each Operator change
- (b) Prior to each sale, lease, or delivery
- (c) In service for 3 months; or Out of service for 3 months or more; or Purchased used
- (d) Annually, no later than 13 months from the date of the prior inspection

### 2.3 SERVICING AND MAINTENANCE GUIDELINES

#### General

---

The following information is provided to assist you in the use and application of servicing and maintenance procedures contained in this chapter.

#### Safety and Workmanship

---

Your safety, and that of others, is the first consideration when engaging in the maintenance of equipment. Always be conscious of component weight. Never attempt to move heavy parts without the aid of a mechanical device. Do not allow heavy objects to rest in an unstable position. When raising a portion of the equipment, ensure that adequate support is provided.

#### WARNING

**NEVER WORK UNDER AN ELEVATED PLATFORM UNTIL PLATFORM HAS BEEN SAFELY RESTRAINED FROM ANY MOVEMENT BY BLOCKING OR OVERHEAD SLING.**

#### Cleanliness

---

The most important single item in preserving the long service life of a machine is to keep dirt and foreign materials out of the vital components. Precautions have been taken to safeguard against this. Shields, covers, seals, and filters are provided to keep the wheel bearings, mast sections and oil supply clean; however, these items must be maintained on a scheduled basis in order to function properly.

At any time when oil lines are disconnected, clear adjacent areas as well as the openings and fittings themselves. As soon as a line or component is disconnected, cap or cover all openings to prevent entry of foreign matter.

Clean and inspect all parts during servicing or maintenance, and assure that all passages and openings are unobstructed. Cover all parts to keep them clean. Be sure all parts are clean before they are installed. New parts should remain in their containers until they are ready to be used.

#### Components Removal and Installation

---

Use adjustable lifting devices, whenever possible, if mechanical assistance is required. All slings (*chains, cables, etc.*) should be parallel to each other and as near perpendicular as possible to top of part being lifted.

Should it be necessary to remove a component on an angle, keep in mind that the capacity of an eyebolt or similar bracket lessens, as the angle between the supporting structure and the component becomes less than 90 degrees.

If a part resists removal, check to see whether all nuts, bolts, cables, brackets, wiring, etc., have been removed and that no adjacent parts are interfering.

#### Component Disassembly and Reassembly

---

When disassembling or reassembling a component, complete the procedural steps in sequence. Do not partially disassemble or assemble one part, then start on another. Always recheck your work to assure that nothing has been overlooked. Do not make any adjustments, other than those recommended, without obtaining proper approval.

#### Pressure-Fit Parts

---

When assembling pressure-fit parts, use an "anti-seize" or molybdenum disulfide base compound to lubricate the mating surface.

#### Bearings

---

When a bearing is removed, cover it to keep out dirt and abrasives. Clean bearings in nonflammable cleaning solvent and allow to drip dry. Compressed air can be used but do not spin the bearing.

Discard bearings if the races and balls (*or rollers*) are pitted, scored, or burned.

If bearing is found to be serviceable, apply a light coat of oil and wrap it in clean (*waxed*) paper. Do not unwrap reusable or new bearings until they are ready to install.

Lubricate new or used serviceable bearings before installation. When pressing a bearing into a retainer or bore, apply pressure to the outer race. If the bearing is to be installed on a shaft, apply pressure to the inner race.

#### Gaskets

---

Check that holes in gaskets align with openings in the mating parts. If it becomes necessary to hand-fabricate a gasket, use gasket material or stock of equivalent material and thickness. Be sure to cut holes in the right location, as blank gaskets can cause serious system damage.

#### Bolt Usage and Torque Application

---

Use bolts of proper length. A bolt which is too long will bottom before the head is tight against its related part. If a bolt is too short, there will not be enough thread area to engage and hold the part properly. When replacing bolts, use only those having the same specifications of the original, or one which is equivalent.

Unless specific torque requirements are given within the text, standard torque values should be used on heat-treated bolts, studs, and steel nuts, in accordance with recommended shop practices or Torque Chart in Section 1.

## Hydraulic Lines and Electrical Wiring

Clearly mark or tag hydraulic lines and electrical wiring, as well as their receptacles, when disconnecting or removing them from the unit. This will assure that they are correctly reinstalled.

## Hydraulic System

Keep the system clean. If evidence of metal or rubber particles is found in the hydraulic system, drain and flush the entire system.

Disassemble and reassemble parts on clean work surface. Clean all metal parts with non-flammable cleaning solvent. Lubricate components, as required, to aid assembly.

## Lubrication and Servicing

Components and assemblies requiring lubrication and servicing are shown in the Lubrication Chart, (See Section-1). Service applicable components with the amount, type, and grade of lubricant recommended in this manual, at the specified intervals. When recommended lubricants are not available, consult your local supplier for an equivalent that meets or exceeds the specifications listed.

## Batteries

Clean batteries, using a non-metallic brush and a solution of baking soda and water. Rinse with clean water. After cleaning, thoroughly dry batteries and coat terminals with an anti-corrosion compound.

## Mast Chain Inspection Procedure

Inspect mast chains for the following conditions:

**Wear:** Always inspect that segment of chain that operates over a sheave. As the chain flexes over the sheaves, joints and plate edges very gradually wear. Chain "stretch" can be measured using a manufacturers wear scale or steel tape. When chains have elongated 3% they must be removed and replaced. Refer to Table 2-3 for proper chain specifications and allowable stretch tolerances. Peening and wear of chain plate edges are caused by sliding over a chain worn contact face of a sheave, or unusually heavy loads. All of the above require replacement of the chain and correction of the cause. Chain side wear, noticeable when pin heads and outside plates show a definite wear pattern, is caused by misalignment of the sheave/chain anchors and must be corrected promptly. Do not repair chains; if a section of chain is damaged, replace the entire chain set.

**Rust and Corrosion:** Rust and corrosion will cause a major reduction in the load carrying capacity of the chain, because these are primary reasons for side plate cracking. The initial lubrication at the factory is applied in a hot dip tank to assure full penetration into the joint. Do not

steam clean or degrease chains. At time of chain installation, factory lube must be supplemented by a maintenance program to provide a film of oil on the chains at all times. If chains are corroded, they must be inspected, especially the outside plates, for cracks in-line with the pins. If cracks are found, replace the chain; if no cracks are discovered, lubricate the chains by dipping in heated oil, and reinstall on the machine. Keep chains lubricated.

Table 2-3. Chain Stretch Tolerance

Chain Size	Pin to Pin Measurement	Allowable Stretch
.50" pitch	12" or 24 pitches	.24 in./12 in. span
.625 pitch	15" or 24 pitches	.30 in./15 in. span

**Fatigue Cracks:** Fatigue is a phenomenon that affects most metals, and is the most common cause of chain plate failures. Fatigue cracks are found through the link holes, perpendicular (*90 degrees*) from the pin in-line position. Inspect chains carefully after long time use and heavy loading for this type of crack. If any cracks are discovered, replace all chains, as seemingly sound plates are on the verge of cracking. Fatigue and ultimate strength failures on JLG Lifts are incurred as a result of severe abuse as design specs are well within the rated lifting capacity of these chains.

**Tight Joints:** All joints in the leaf chain should flex freely. On leaf chain, tight joints are usually caused by rust/corrosion, or the inside plates "walking" off the bushing. Limber up rusty/corroded chains (*after inspecting care fully*) with a heavy application of oil (*preferably a hot oil dip*). Tap inside "walking" plates inward; if "walking" persists, replace the chain. This type of problem is accelerated by poor lubrication maintenance practice, and most tight joint chains have been operated with little or no lubrication. Tight joints on leaf chain are generally caused by:

- Bent pins or plates.
- Rusty joints.
- Peened plate edges.

Oil rusty chains, and replace chains with bent or peened chain components. Keep chains lubricated.

**Protruding or Turned Pins:** Chains operating with inadequate lube generate tremendous friction between the pin and plates (pin and bushing on leaf chain). In extreme cases, this frictional torque can actually turn the pins in the outside press-fit plates. Inspect for turned pins, which can be easily spotted as the "V" flats on the pin heads are no longer in line. Replace all chains showing evidence of turned or protruding pins. Keep chains lubricated.

**Chain Anchors and Sheaves:** An inspection of the chain must include a close examination of chain anchors and sheaves. Check chain anchors for wear breakage and misalignment. Anchors with worn or broken fingers should

## SECTION 2 - GENERAL

---

be replaced. They should also be adjusted to eliminate twisting the chain for an even load distribution.

Inspect the sheaves, sheave bearings, sheave grooves and pins for extreme wear, replace as necessary. A worn sheave can mean several problems, as follows:

- a. Chains too tight.
- b. Sheave bearings/pin bad.
- c. Bent/misaligned chains.

---

## 2.4 LUBRICATION INFORMATION

### Hydraulic System

---

The primary enemy of a hydraulic system is contamination. Contaminants enter the system by various means, e.g., using inadequate hydraulic oil, allowing moisture, grease, filings, sealing components, sand, etc., to enter when performing maintenance, or by permitting the pump to cavitate due to insufficient system warm-up or leaks in the pump supply.

The design and manufacturing tolerances of the component working parts are very close, therefore, even the smallest amount of dirt or foreign matter entering a system can cause wear or damage to the components and generally results in faulty operation. Every precaution must be taken to keep hydraulic oil clean, including reserve oil in storage.

Cloudy oils indicate a high moisture content which permits organic growth, resulting in oxidation or corrosion. If this condition occurs, the system must be drained, flushed, and refilled with clean oil.

It is not advisable to mix oils of different brands or types, as they may not contain the same required additives or be of comparable viscosities. Good grade mineral oils, with viscosities suited to the ambient temperatures in which the machine is operating, are recommended for use.

**NOTE:** *Metal particles may appear in the oil of new machines due to the wear-in of meshing components.*

### Hydraulic Oil

---

For best performance, JLG recommends the use of ISO-Vg grade 32, 46 oil with a viscosity range between 15-250 SUS at 100 degrees F (*32-54 cST at 40 degrees C*). Refer to Section 1-5 of this Service Manual for recommended hydraulic oils.

### Changing Hydraulic Oil

---

Use of any of the recommended hydraulic oils eliminates the need for changing the oil on a regular basis. If it is necessary to change the oil, use only those oils meeting or exceeding the specifications appearing in this manual. If unable to obtain the same type of oil supplied with the machine, consult local supplier for assistance in selecting the proper equivalent. Avoid mixing petroleum and synthetic base oils. JLG Industries recommends changing the hydraulic oil annually.

Use every precaution to keep the hydraulic oil clean. If the oil must be poured from the original container into another, be sure to clean all possible contaminants from the service container.

While the unit is shut down, a good preventive maintenance measure is to make a thorough inspection of all hydraulic components, lines, fittings, etc., as well as a functional check of each system, before placing the machine back in service.

### Lubrication Specifications

---

Specified lubricants, as recommended by the component manufacturers, are always the best choice, however, multi-purpose greases usually have the qualities which meet a variety of single purpose grease requirements. Should any question arise regarding the use of greases in maintenance stock, consult your local supplier for evaluation. Refer to Section-1 in this Service Manual for an explanation of the lubricant key designations appearing in the Lubrication Chart.

## 2.5 POSITIONING LIFT FOR ACCESS TO COMPONENTS LOCATED UNDER THE BASE FRAME

Access to the underside of the VP lift can be obtained by lifting the machine with a fork lift truck, using the fork lift pockets in the base frame.

### Lifting with a Fork Truck (See Figure 2-1.)

1. Choose a fork lift truck capable of safely handling the full weight of the machine.
2. Locate work area on a firm, level surface.

### **⚠ WARNING**

KEEP MACHINE LEVEL OR SLIGHTLY TILTED TOWARD FORK-LIFT TRUCK WHEN LIFTING TO PREVENT MACHINE FROM SLIDING OFF LIFTING TINES.

3. When lifting with a fork truck, lift only using the fork lift-truck pockets running the length of the machine's base frame from rear to front.
4. After lifting machine to desired work height, place support stands under the machine. The support stands must reach from the floor to the bottom of the machine and be capable of safely handling the weight of the machine.

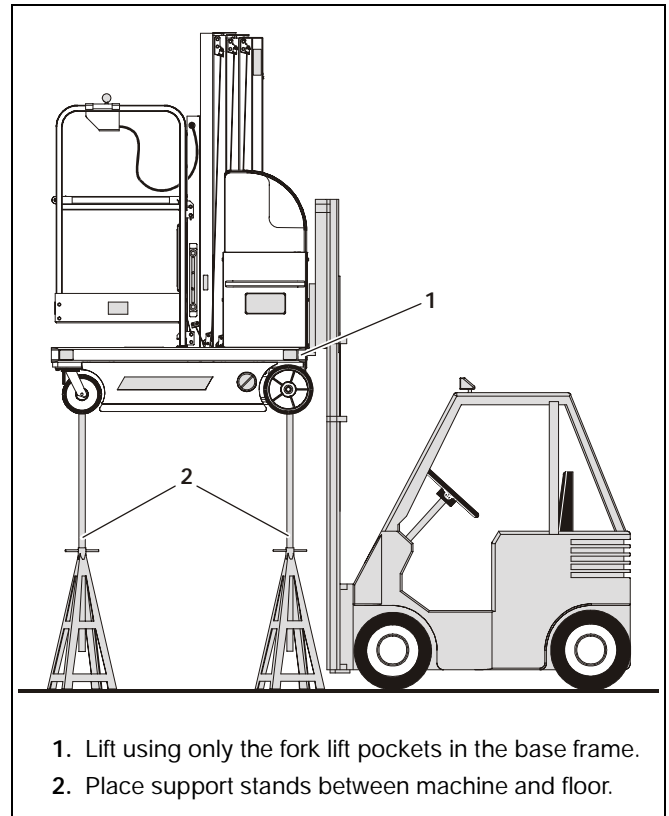

**Figure 2-1. Accessing Machine Underside Components by Lifting with a Fork Truck.**

**This page intentionally left blank.**

SECTION 3. BASE COMPONENTS

3.1 BASE ASSEMBLY COMPONENTS

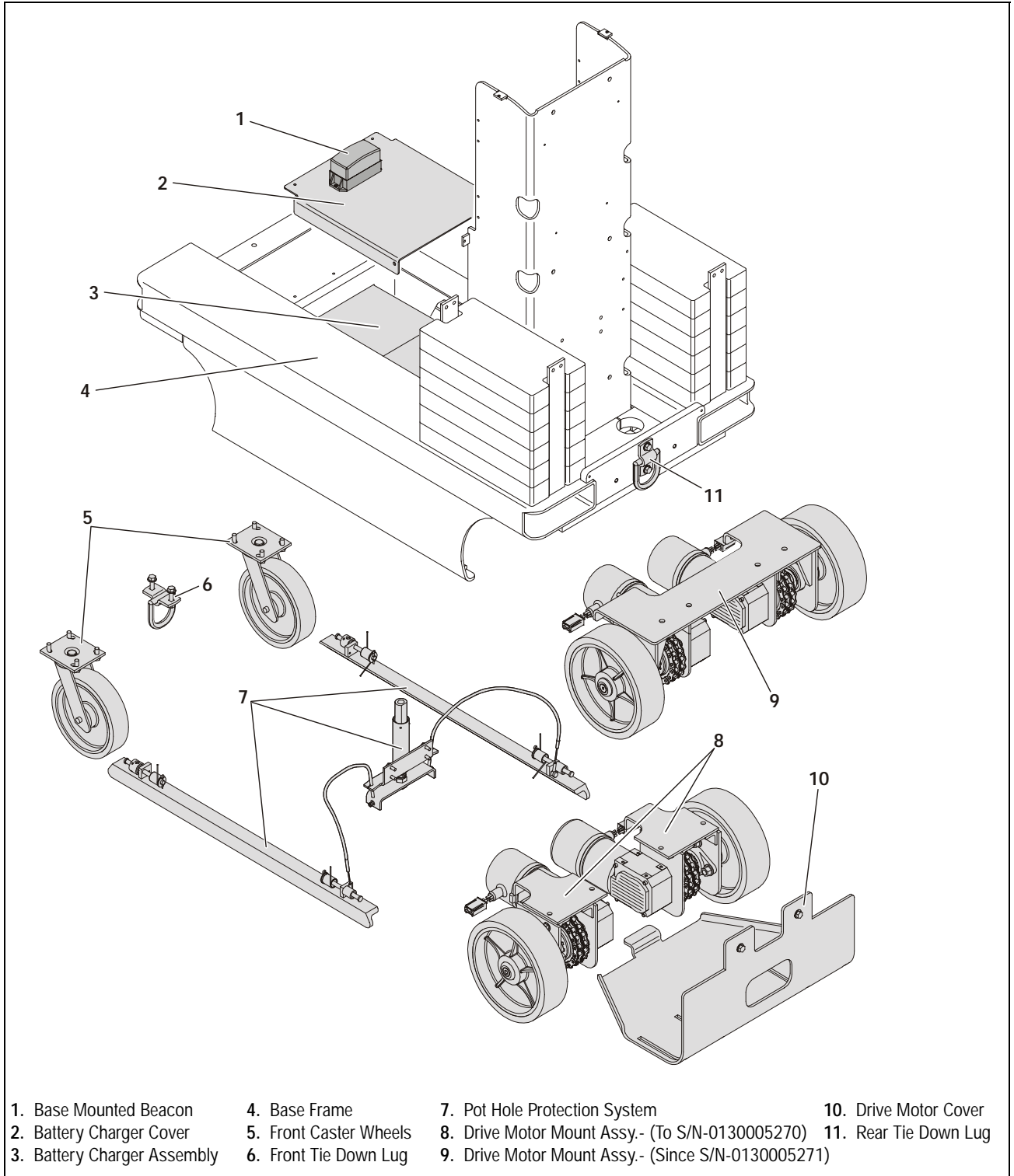
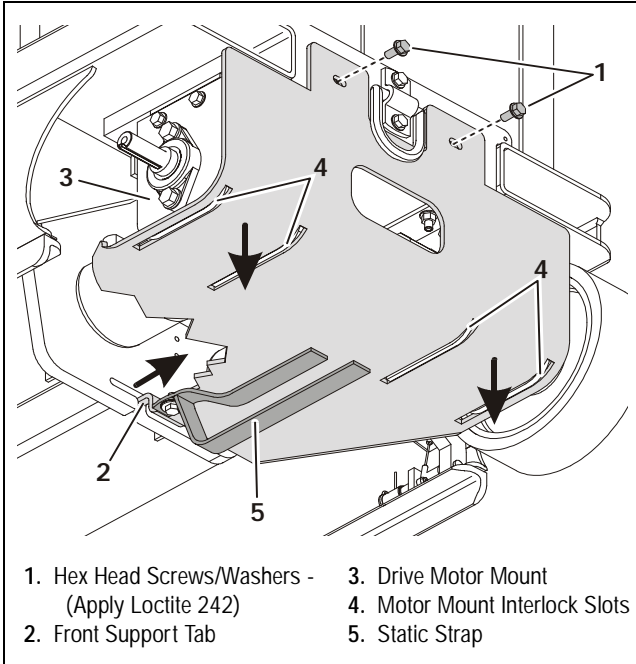

Figure 3-1. Base Components.

3.2 BASE FRAME COVERS

Drive Motor Cover - Installation



Battery Charger Cover - Installation

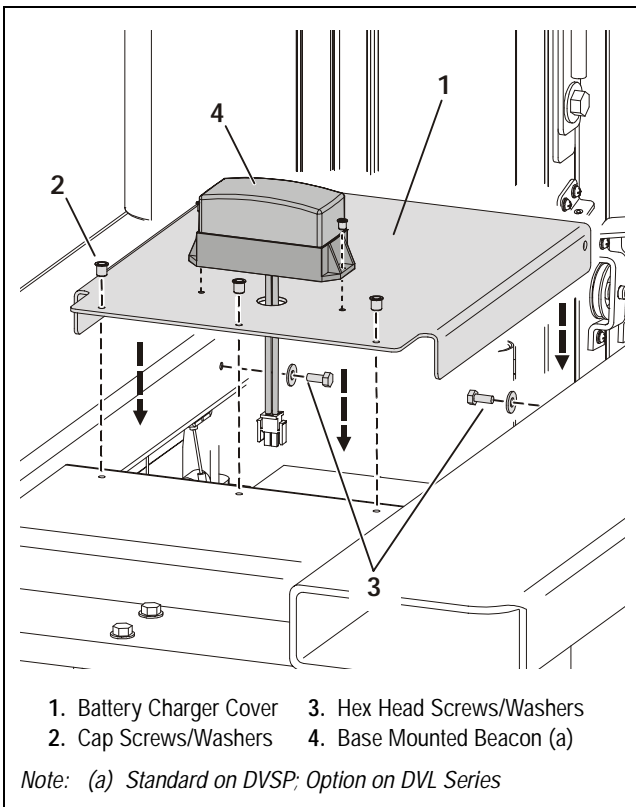

3.3 DRIVE AND CASTER WHEELS

Drive Motor Wheel (Std.) - Installation

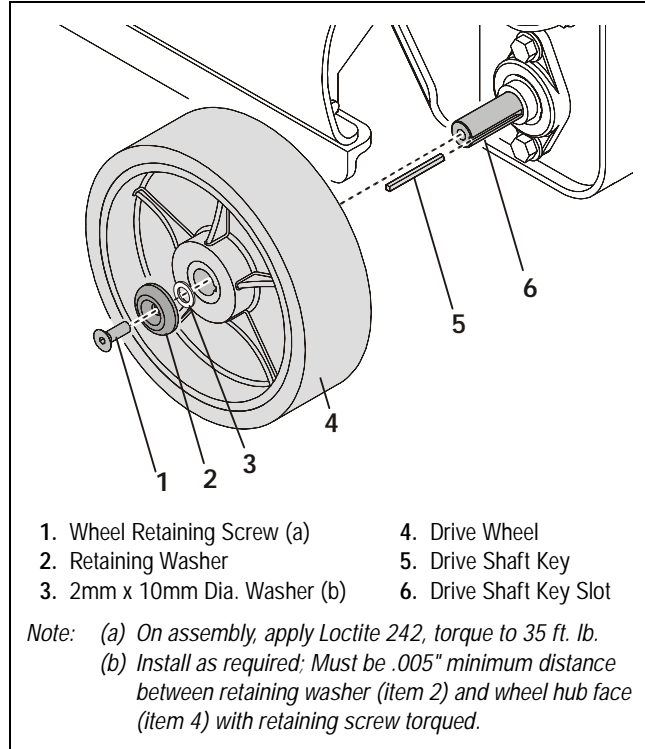

Caster Wheels - Installation

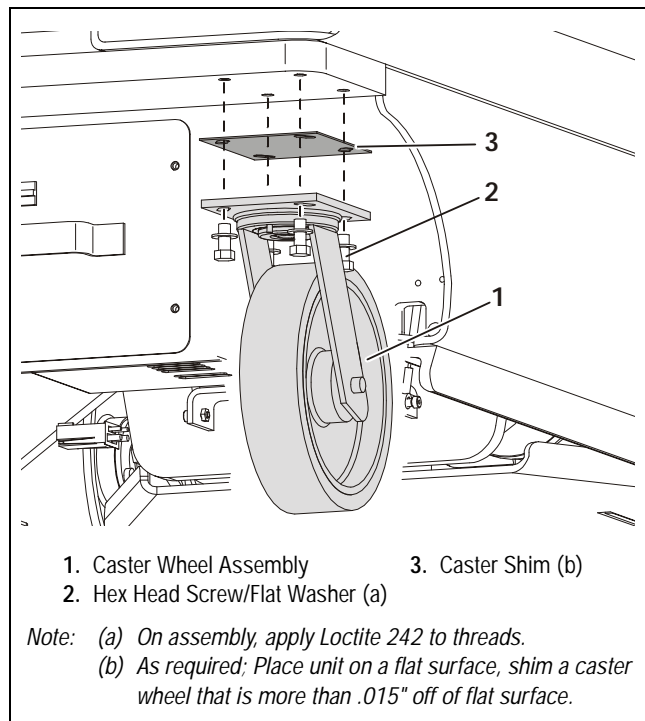



### Wheel Retention for Rough Terrain Drive Wheel (Option)

1. The rough terrain drive wheel is installed same as the regular drive wheel except - place the wheel onto drive motor shaft ensuring that the deepest point of the rim, 5/8" as shown below, is facing out.

*Failure to do so will result in the drive wheel rubbing the drive motor cover.*

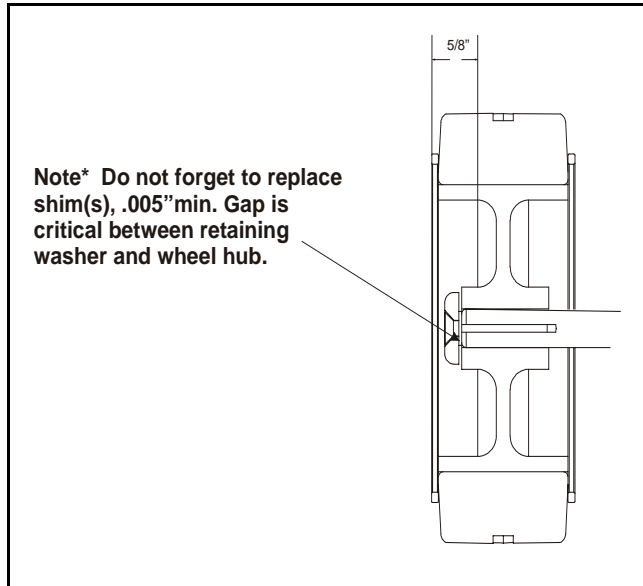

2. Replace shims and the retaining washer.
3. Apply Loctite #242 onto retaining screw and install with a torque rating of 35 ft lb.

#### **IMPORTANT**

FAILURE TO APPLY LOCTITE #242 TO THE RETAINING SCREW AND TORQUING THE RETAINING SCREW TO 35 FT LB MAY RESULT IN THE WHEEL COMING LOOSE AND FALLING OFF

### 3.4 DRIVE MOTOR COMPONENT - SERVICING

#### Torque Limiting Clutch Maintenance

DVL Series and DVSP machines are equipped with a torque limiting clutch coupling on each drive axle. The clutch is mounted in line on a split drive axle between the drive wheel and the drive motor gear box. The clutch is designed to slip at a preset torque (220 ft. lb.) if the machines rear wheels are over-driven while the machine is being towed, pushed or forklifted, thus preventing damage to the drive gear box.

Although factory pre-set, the clutch assembly torque setting should be checked;

- Annually - during Annual Inspection

However, if the lift is being moved via a fork truck on a regular or frequent basis, then the torque clutch may be forced into a slipping mode, as intended to protect the drive train. In that case, and if slippage occurs during machine operation, then the torque setting should be checked;

- Every 3 Months

And the torque specification reset per the following instructions.

#### Diagnosics

A torque clutch with INCORRECT torque setting may develop the following symptoms;

- Machine does not drive straight.

**NOTE:** Machine pulling to one side can also be the result of low battery voltage. Be sure and check battery voltage before clutch maintenance begins.

- There is gray dust accumulating around the drive motor(s) due to excessive clutch wear.

## SECTION 3 - BASE COMPONENTS

### Visual Inspection and Limiting Torque Checking Procedure

Special tools required:

- Torque Wrench (capable of setting torque in the range of 220 ft. lb.
- Special tool part # 0080229
- 2-3/8" open end wrench
- Loctite #242

1. Locate the machine on a firm level surface.
2. Before clutch torquing can begin, you must remove the wheels using the following procedure:

**NOTE:** Machines equipped with Rough Terrain Wheels, make a visible mark on the wheel so the wheel does not get inverted when reinstalled.

- a. Using a fork truck, raise unit approximately 12" off the floor and support in a safe manner.

**NOTE:** (See Section 3.3, Drive And Caster Wheels, illustration)

- b. Remove the wheel retaining screw (1) from axle assembly. Clean threads of screw.
- c. Remove retaining washer (2), and shim(s) (3).
- d. Slide wheel (4) from axle.

3. Remove the Drive Motor Cover from under machine, see instructions previously outlined in this section of the manual.

4. Carefully raise the lift to gain access to the underside of the base frame. Refer to "Positioning Lift For Access to Components Located Under the Base Frame" in Section 2.

5. Locate the clutch assembly on each rear drive axle and check for the following;

- a. Check the coupling chains for any loose or missing parts, i.e. pins, links, etc., replace if necessary.
- b. Check that at least three (3) of the lock tabs on the clutch adjusting nut - lock washer are properly bent and the nut is secure.
- c. Check for any debris wedged in or wrapped around the clutch coupling chains and axle shafts. Remove debris and clean area if necessary.

### Check Clutch Torque Setting

1. Select a torque wrench capable of setting a torque of 220 ft. lb. Insert special tool (P/N-0080229) into a 1-3/4" socket on the torque wrench.
2. Slide the tool onto the end of the drive axle aligning the key on the axle shaft (install key on axle, if necessary), with key slot in the tool.

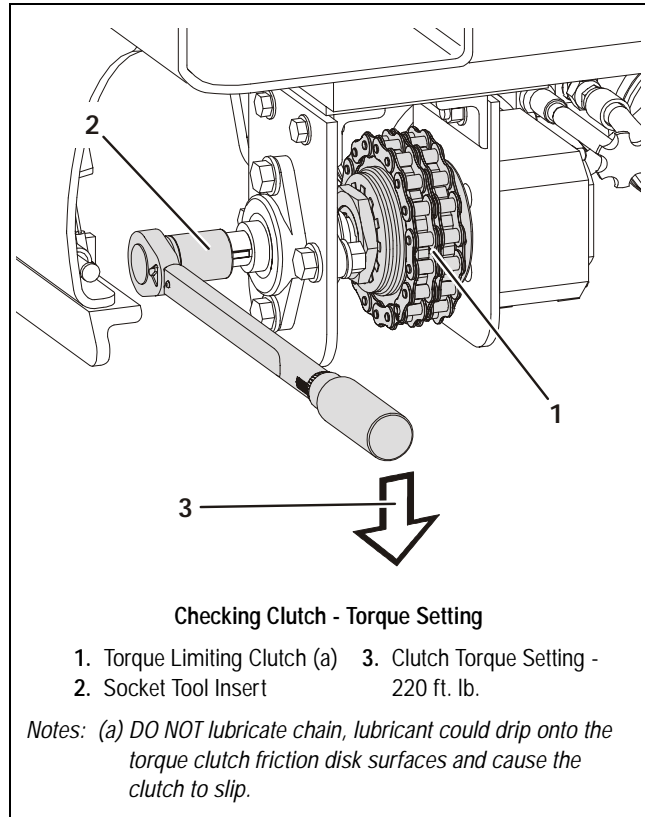

3. Set the torque wrench to the proper torque setting - 220 ft. lb.
4. Turn the torque wrench and note the torque setting when the torque limiting clutch slips. Check both rear drive axles.
5. If torque setting is OK, re-install the drive motor cover and drive motor wheels and lower machine.

IF NOT, continue with Torque Limiting Clutch Adjustment following.

### Torque Limiting Clutch Adjustment

**NOTE:** The large adjusting nut on the side of the clutch assembly is a standard type thread. If the torque (slip) setting of the clutch assembly is off spec 220 ft. lb., the large adjusting nut must be (tightened) turned clockwise to increase the torque setting or (loosened) counter-clockwise to decrease the torque setting.

1. Bend lock tabs away from the adjusting nut.
2. Hold the drive axle steady using service tool (P/N-0080229) and the torque wrench used to check the torque setting.
3. Depending on how far off the original torque setting was (see note at beginning of this procedure), tighten or loosen the adjusting nut accordingly, then recheck the (slip) torque setting. Repeat this until the proper (slip) torque setting is achieved.
4. When proper torque setting is achieved, bend three (3) of the lock washer - lock tabs down against the adjust nut.
5. Re-install the drive wheels per instructions Section 3.3, Drive And Caster Wheels.

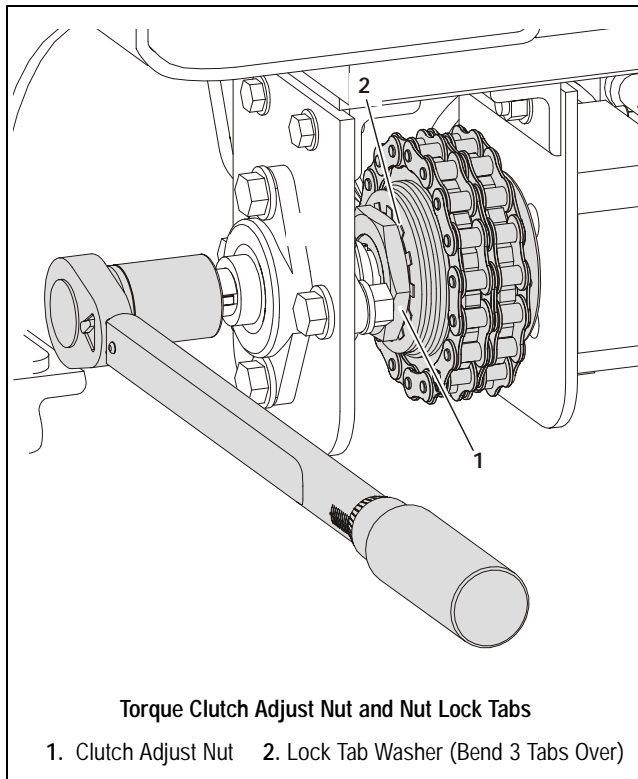

### Drive Wheel Alignment - (Machines built prior to S/N-0130005271)

The following procedure corrects DVL/DVSP machine drive wheel alignment, if required. A drive wheel must be aligned if the wheel is more than 1/16" (2mm) off of vertical alignment with machine resting on a level surface.

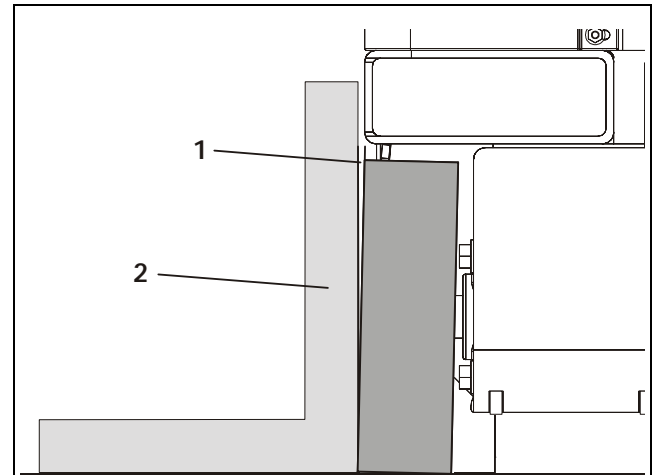

#### Checking Drive Wheel Alignment

1. Drive Wheel Vertical Alignment - Maximum 1/16" (2mm) Gap Between Top and Bottom Edge of Wheel.
2. Use a Steel Carpenter's Square or equivalent to Check.

**Note:** Check with machine resting on a smooth level surface.

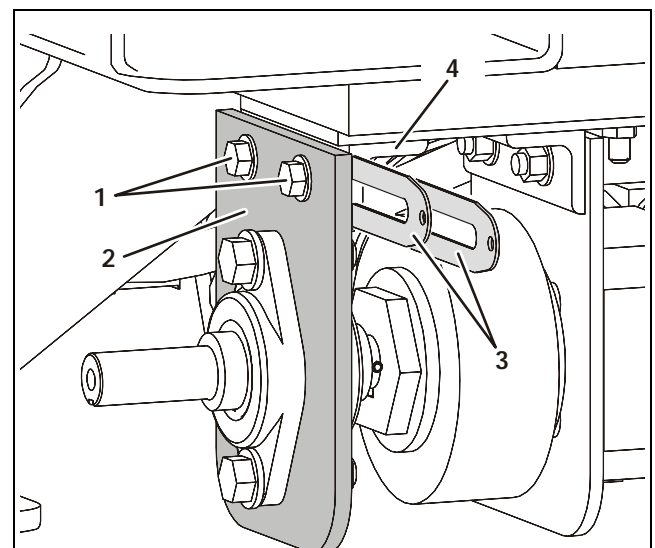

#### Adding Shims To Correct Alignment

1. Hex Head Screws
2. Bearing Mounting Plate
3. 16Ga. (.0598"/1.5mm) Shim(s)
4. Drive Assembly Mount

**Note:** Lift Machine, Remove Drive Motor Cover and Drive Wheel.

### 3.5 DRIVE MOTOR ASSEMBLY - SERVICING

**NOTE:** *The following drive motor servicing instructions refer to machines built to both the original design - (Machines built prior to Serial Number - 0130005271) and a new design - (Machines built since Serial Number - 0130005271). The major difference between the two designs is the drive motor mounting frame, the original is two separate mounting frames the new design is a one piece frame mount.*

Components on the drive motor assemblies may be serviced without removing the motor mounting frame assembly(s) from the machine, if necessary.

The component parts of the left and right drive motor assemblies are identical except for the drive motor mounting frame assembly.

### Drive Motor Assembly - Removal

---

(See Figure 3-2. or Figure 3-3.)

The DVL/DVSP drive motor assemblies are mounted independently of each other on a completely removable drive assembly mounting frame(s) at the rear of the machine. The drive assembly mounting frame is fastened to the base frame at the top and interlocks with slots in the drive motor cover at the bottom.

1. Disconnect the positive battery terminal from the left side battery.
2. Remove the drive motor assembly cover and set aside, see Section 3.2, Base Frame Covers.
3. Disconnect the drive motor harness connector(s) from the traction module mounted just above the hydraulic pump motor, located under the rear machine covers. Guide motor harness down through base frame.
4. Carefully raise the lift to gain access to the underside of the base frame. Refer to Section 2-5, "Positioning Lift For Access to Components Located Under the Base Frame".
5. Remove the hex head cap screw and washer from the front of the drive assembly mounting frame.
6. While holding the drive motor assembly in place, remove the nut and washer from the remaining hex head cap screw holding the drive assembly mounting frame to the base frame.
7. Lower the drive motor assembly from the machine and place on a suitable work bench for disassembly.

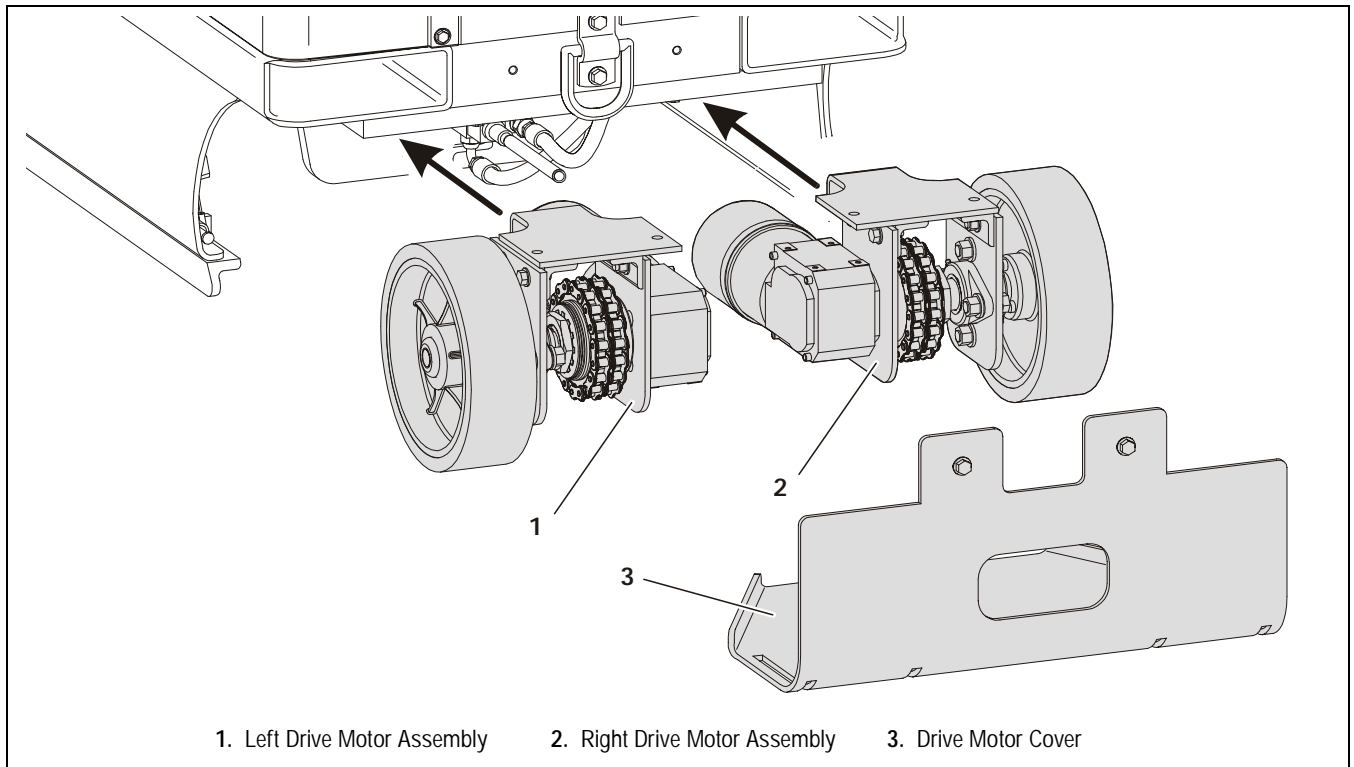

Figure 3-2. Drive Motor Assembly Components. (Machines built prior to S/N-0130005271)

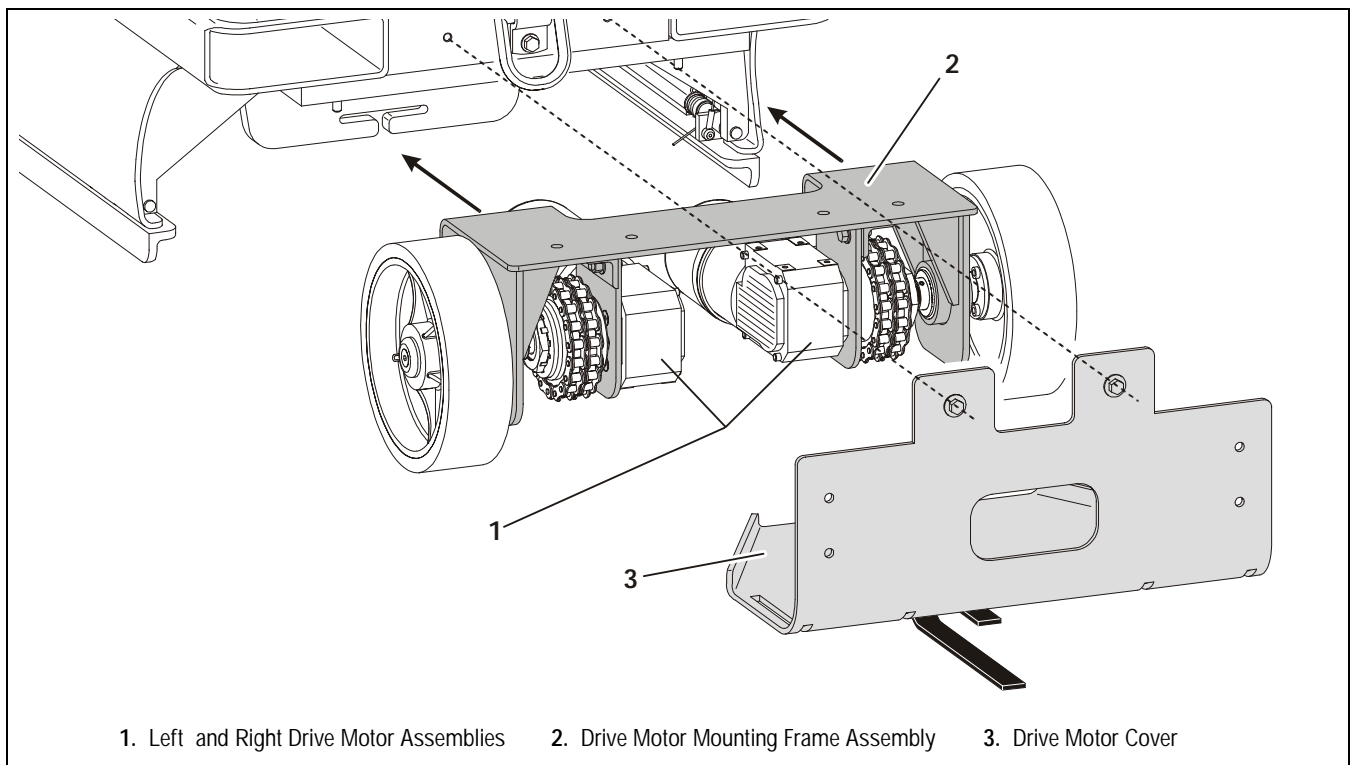
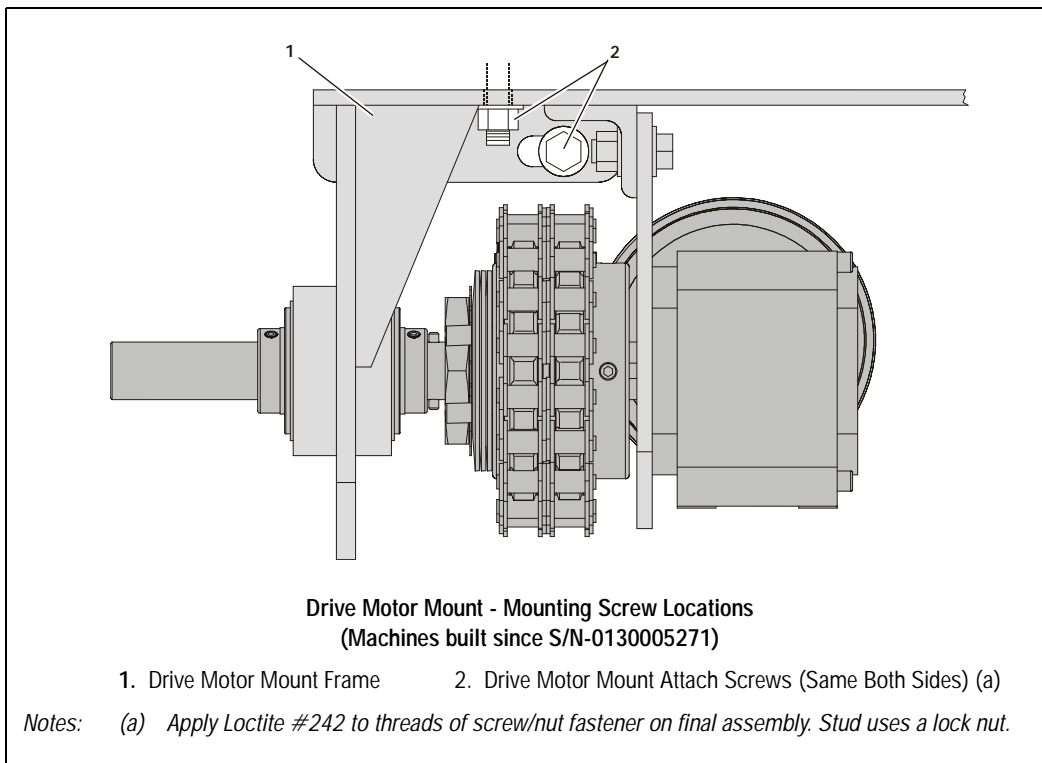
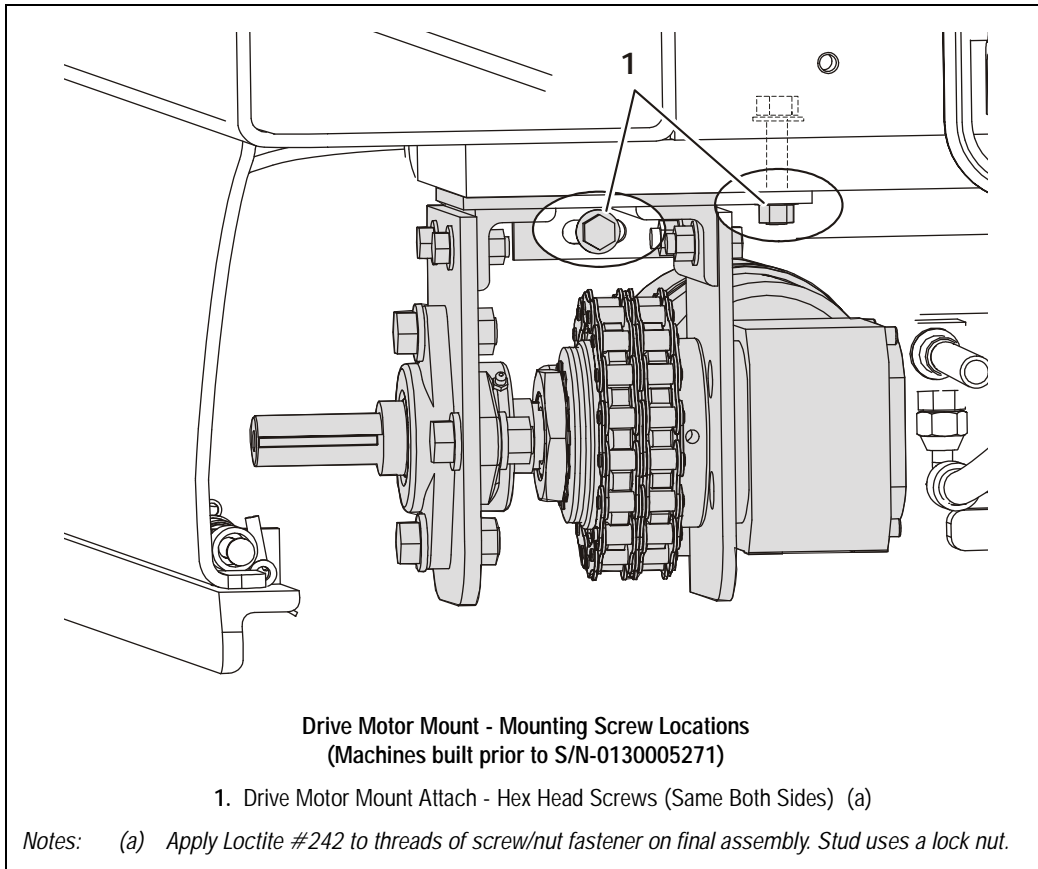

Figure 3-3. Drive Motor Assembly Components. (Machines built since S/N-0130005271)



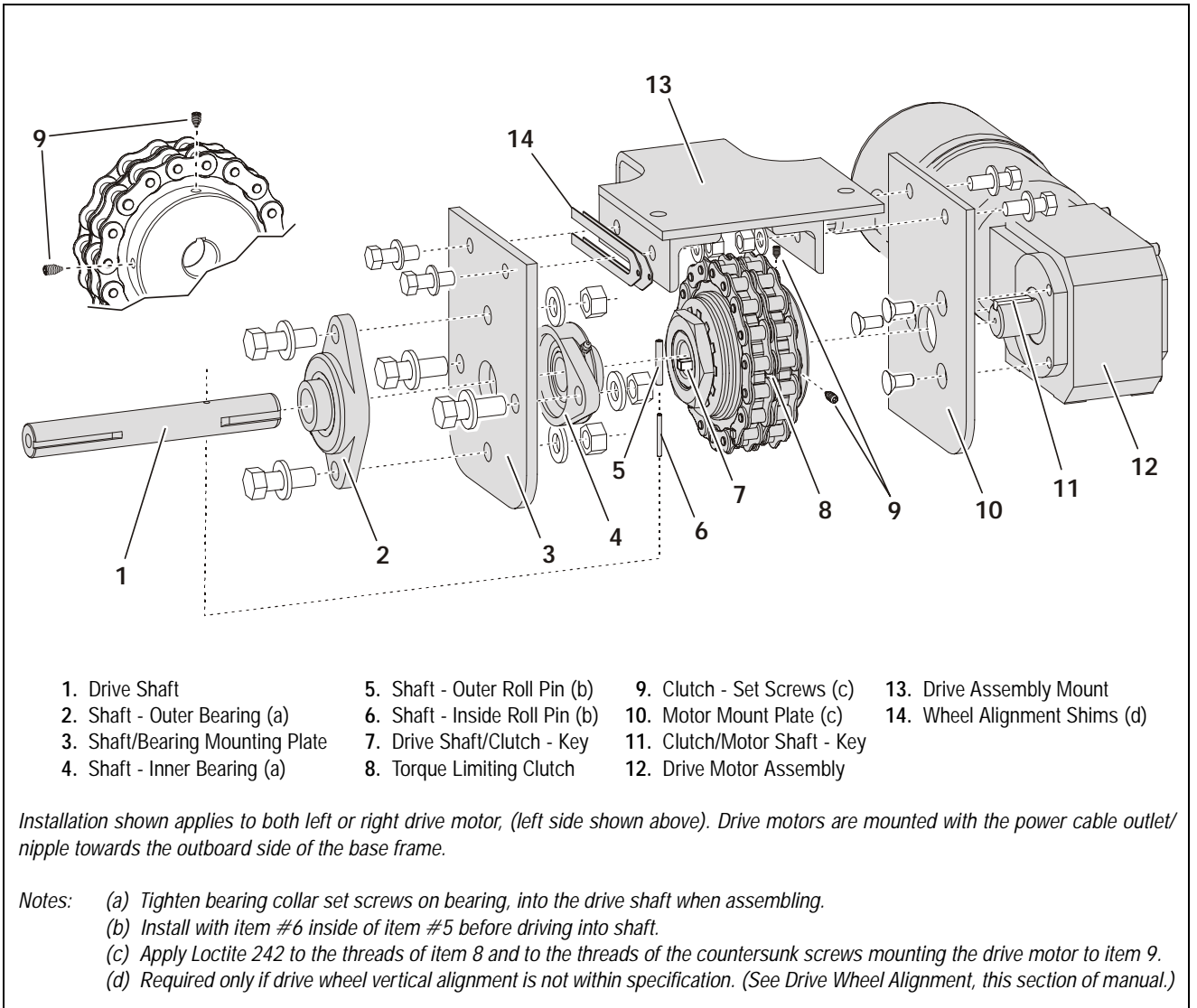
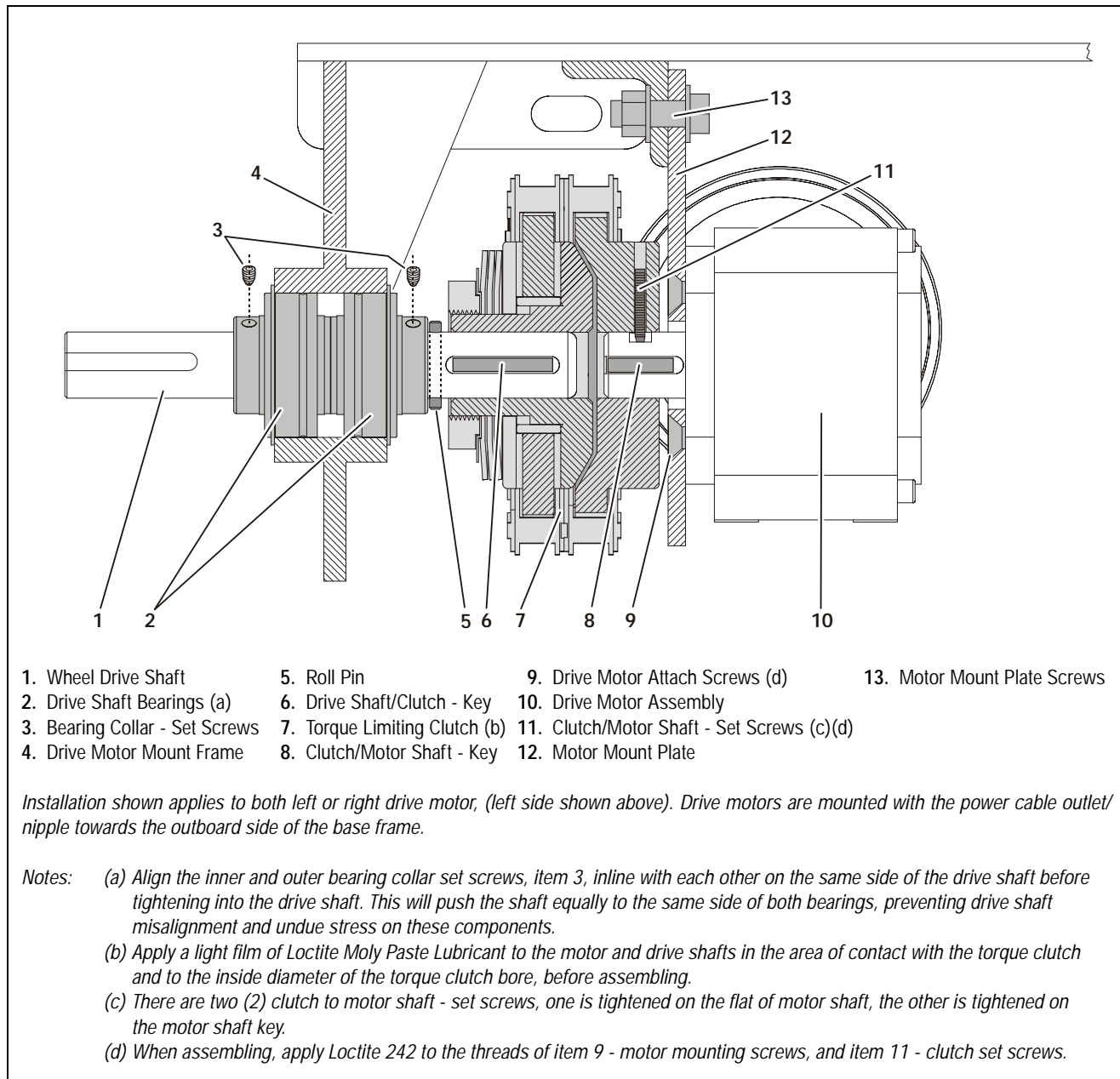

Figure 3-4. Drive Motor Component Assembly (Machines built prior to S/N-0130005271)

## SECTION 3 - BASE COMPONENTS



**Figure 3-5. Drive Motor Component Assembly (Machines built since S/N-0130005271)**



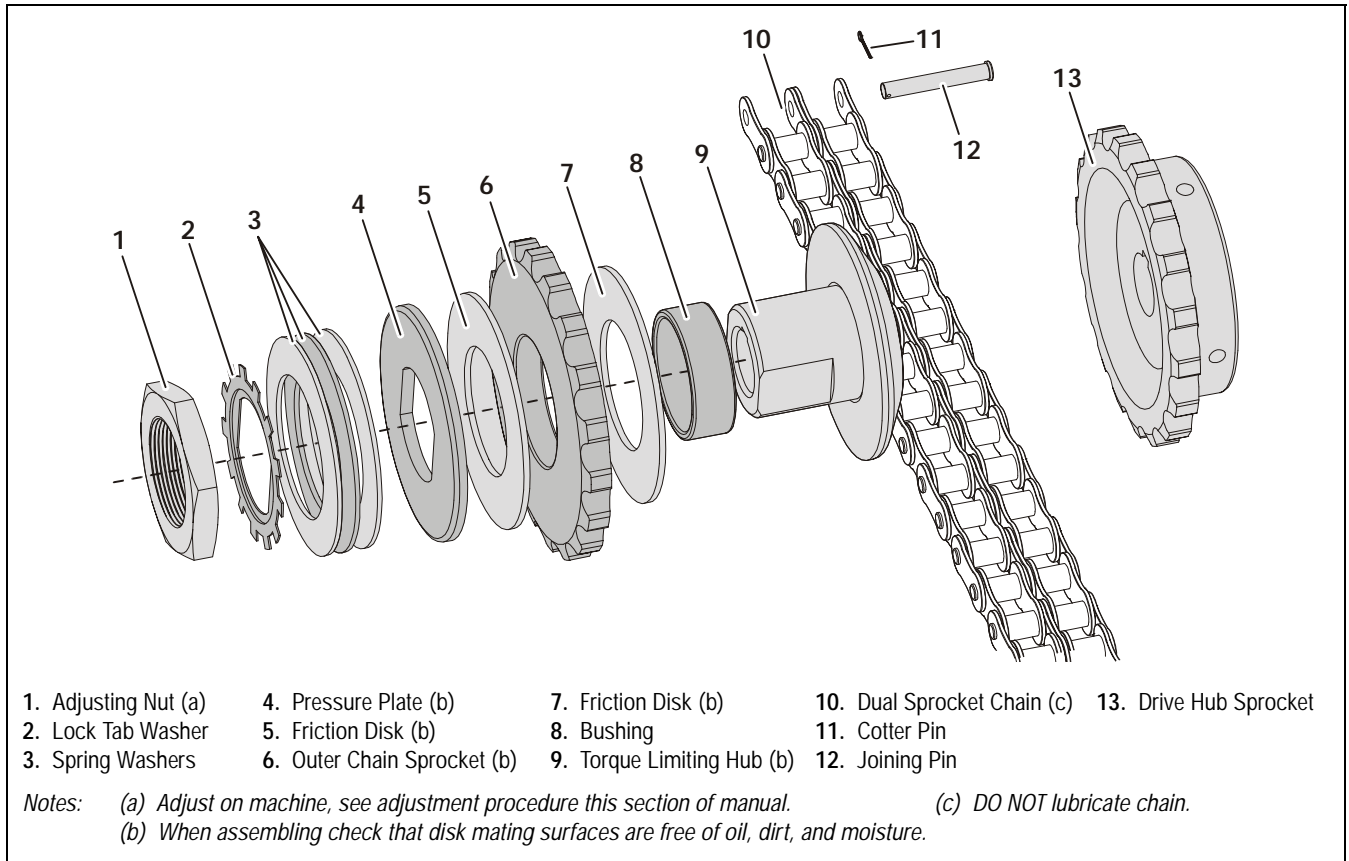
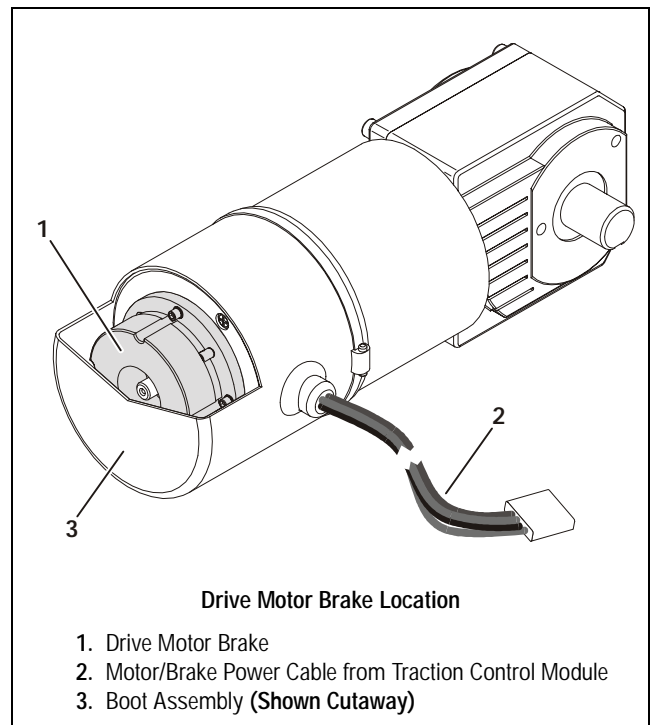

Figure 3-6. Torque Limiting Clutch Assembly

### Drive Motor Brake Removal and Adjustment

A brake assembly is mounted to the front of each drive motor housing. The brakes are ENGAGED (*brakes on*) when the machine is parked and are RELEASED electrically (*brakes off*) when the joystick is enabled and pushed in any direction. The brakes can also be RELEASED electrically using the manual brake release button on the ground control station.

**NOTE:** The brakes are intended only as parking brakes to keep the machine from moving while at rest. The brakes are not used to stop the machine during driving operations, this braking is controlled by the drive motors themselves. Under normal driving conditions, once released the brakes are not engaged again until the machine comes to a complete stop.



**Brake Operation** (See Figure 3-7.)

When the magnetic coil is not energized (*brake on*), the armature plate is pushed away from the magnetic coil surface by heavy springs internally mounted in the magnetic coil housing. This pressure forces the armature plate against the friction brake disk holding it tight between the armature plate and the mounting plate. The friction brake pad is mated to the drive motor armature shaft. The brake is not released until the magnetic coil is energized pulling the armature plate away from the friction brake disk.

A correctly adjusted brake will ideally have a measurement of approximately .006" (*but will operate normally at .004" to .010"*) between the armature plate and magnetic coil housing surface when the brakes are ENGAGED (*brakes on*).

Never allow any type of lubricant (oil, grease, hydraulic fluid, etc.) to come in contact with the brake friction disk or it's contacting surfaces. Also if the brake becomes clogged with debris or dirt the brake may not release properly.

**Brake Assembly Removal**

1. Lift the machine to gain access to the underside (See Section 2-5.).
2. Remove the drive motor cover (See Section 3.2).
3. Disconnect the drive motor power connector from it's wiring harness connector.
4. Loosen the boot clamp, and slide the protective rubber boot off the end of the drive motor housing exposing the brake assembly.
5. Remove the four (4) hex cap screws securing the brake assembly to the end of the drive motor housing and remove the brake assembly from the end of the drive motor.

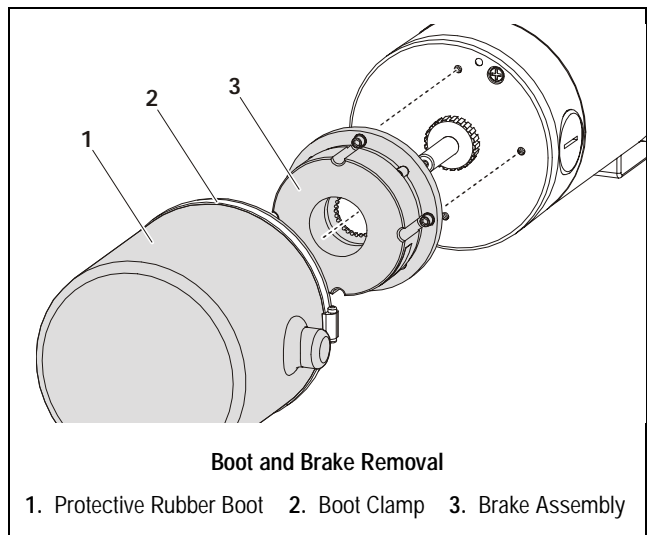

**Checking/Adjusting Armature Plate Gap Setting**

1. First inspect that all parts of the brake assembly are tight and secure. Tighten as necessary.
2. Inspect the brake for any debris which may be lodged in the air gap between the armature plate and magnetic coil when the brakes are ENGAGED (*brakes on*); on either side of the friction disk when the brake is RELEASED (*brakes off*). Clean and remove debris as necessary.
3. With the brakes ENGAGED measure the air gap between the armature plate and the magnetic coil housing. The correct setting should be .006", however the brakes will operate properly if the measurement is a minimum of .004" and a maximum of .010". (See "Gap Setting" Illustration this Section)
4. If the air gap falls outside the maximum allowable setting of .010" the friction disk has worn. To correct this replace the disk with a new one.
5. If the air gap is below the minimum allowable setting of .004", recheck the areas between the magnetic coil housing, armature plate, friction disk and mounting plate for debris. Clean as necessary.

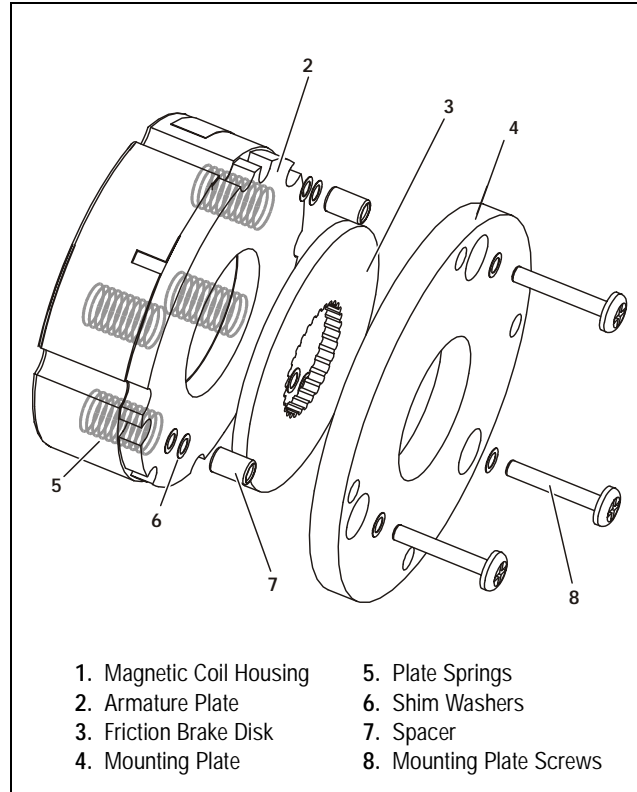

**Figure 3-7. Brake Assembly Components**

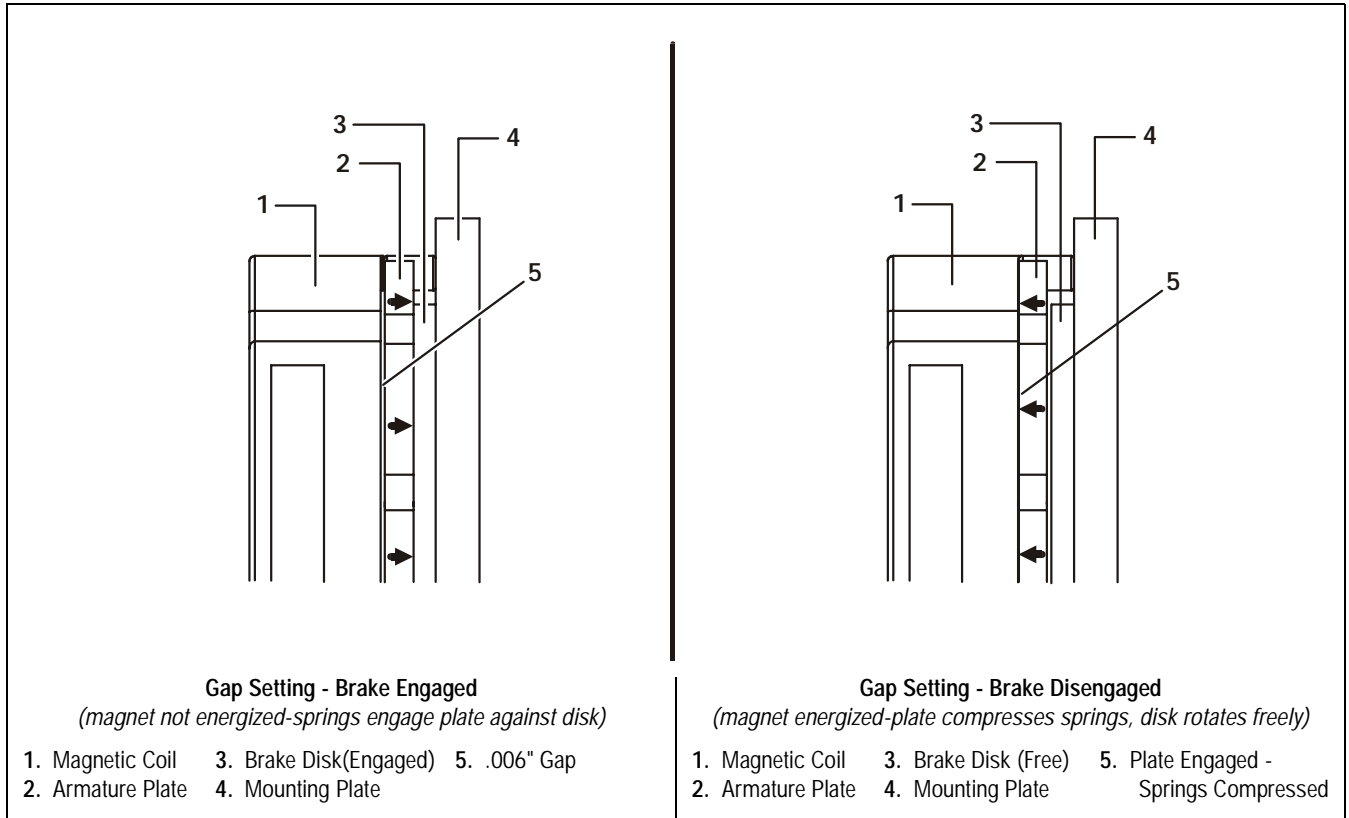

### Brake Assembly Installation

1. Secure the brake assembly to the drive motor housing using four (4) hex cap screws with washers. Torque evenly to 44 in. lbs.
2. Reinstall the protective rubber boot over the drive motor housing, secure the boot with the boot clamp.
3. Reconnect the drive motor/brake power wiring connector to wiring harness connector.
4. Install the drive motor cover.

Drive Motor Boot Assembly Installation

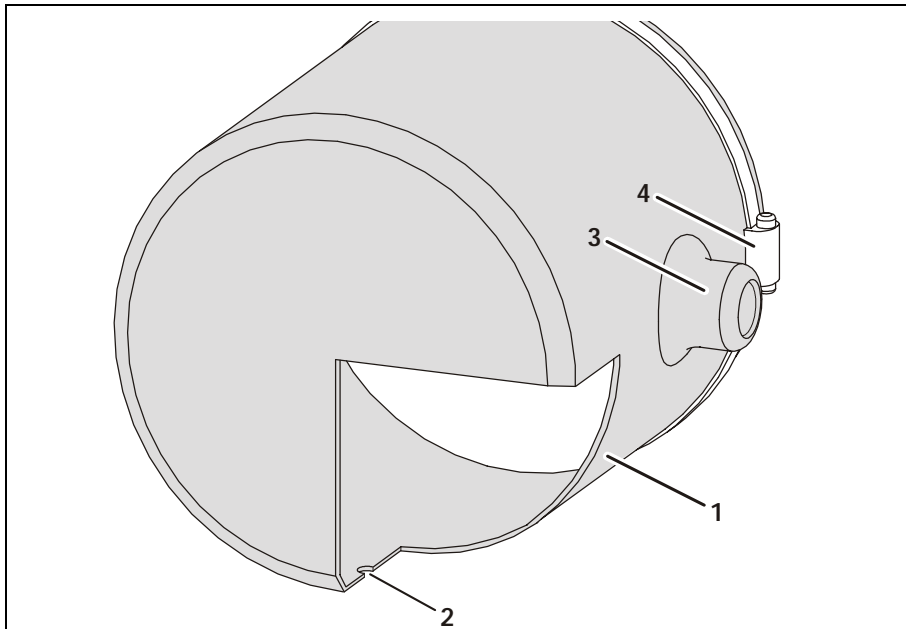

Drive Motor Boot Assembly Installation

- 1. Boot Assembly (Left Drive Motor Boot Shown Cutaway)
- 2. Drain Hole (Always Locate on Bottom of Boot) (a)
- 3. Wiring Harness Nipple
- 4. Boot Clamp

*Note: (a) If replacing the boot assembly, cut a hole approximately 3/16 inch (4mm) size on the **BOTTOM** of the new boot. This will allow any accumulated condensation to drain out.*

*The Left and Right Drive Motor use the same replacement boot, however the wiring harness nipple on the boot always points towards the outside of the machine. The drain hole must always be located on the **BOTTOM** of the boot, see illustration below.*

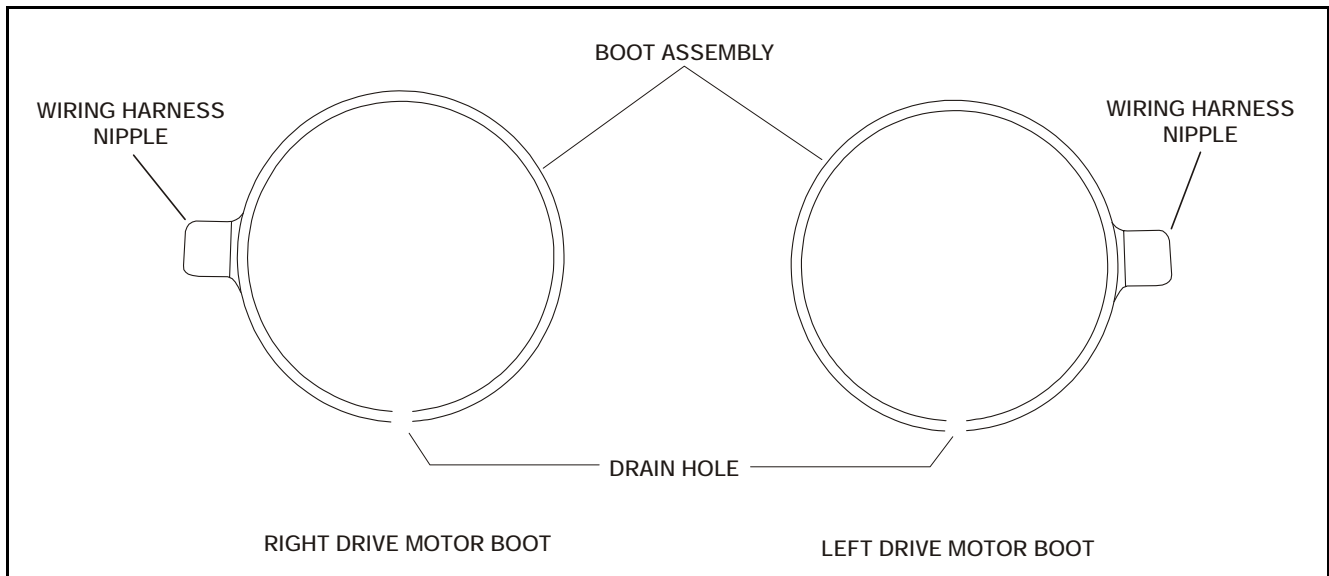

### Drive Motor Brush Replacement

Each drive motor contains two (2) brushes, the brushes are located under the two (2) large round slotted brush caps on the front end of each drive motor.

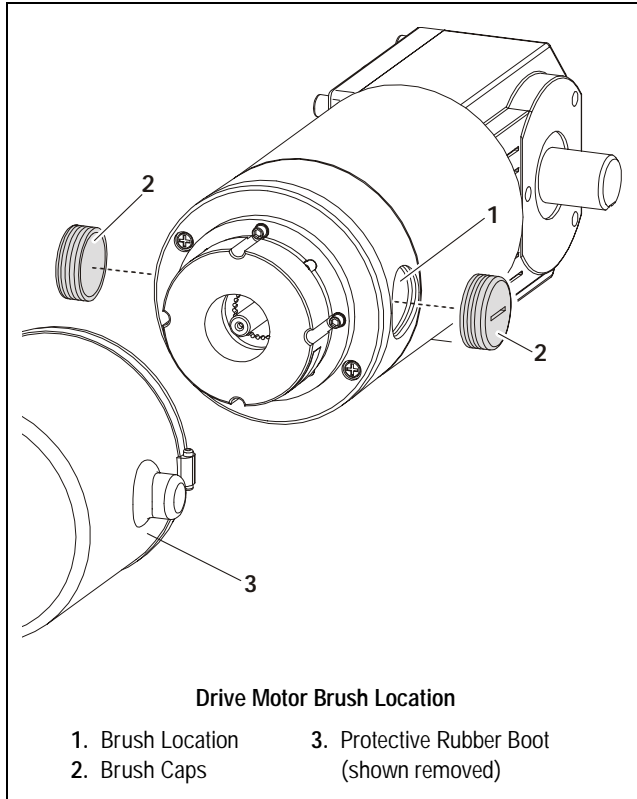

### **⚠ WARNING**

DISCONNECT THE POWER LEADS FROM THE POWER SOURCE BEFORE INSPECTING OR REPLACING BRUSHES.

### Brush Cleaning and Inspection

Brush wear rate varies depending on the individual machine application duty cycle. The drive motor brushes should be inspected every 600 hrs or 1 year of operation. Brushes should be replaced before they are less than .375 in. (9.5mm) in length. Carbon dust accumulation should be removed periodically. If the end shield has been removed from the drive, a clean, dry, non-linting cloth can be used for cleaning. DO NOT use solvents as they may damage non-metallic parts and adversely affect subsequent brush commutation.

### Brush Removal

Removal of the brushes also requires the removal of the drive motor(s) from the machine, see procedure described earlier in this section for instructions to remove the drive motors. If not already done, disconnect the positive (+) battery cable from the left side battery before proceeding.

1. Remove the clamp and protective rubber boot from the drive motor.
2. Unscrew the large round brush caps from each side of the drive motor, use as large a screw driver as possible.
3. The brushes are retained by constant-force, roll-type springs. To remove the springs, press inward on the end of the spring retaining bracket using the tip of a pair of long nose pliers or other appropriate tool. The brushes should pop out, if not, they can be removed by pulling outward on the spring brackets with a pair of long nose pliers after the inside ends are unhooked.
4. Now pull the brush out of the brush box by it's wire (*pig-tail*).

**NOTE:** If only inspecting the brushes, it is not necessary to remove the pig-tail terminal from it's connection to the brush box.

5. Loosen the screw securing the pig-tail terminal end to the brush box and slide the terminal end out from under the screw completely removing the brush from the drive motor.

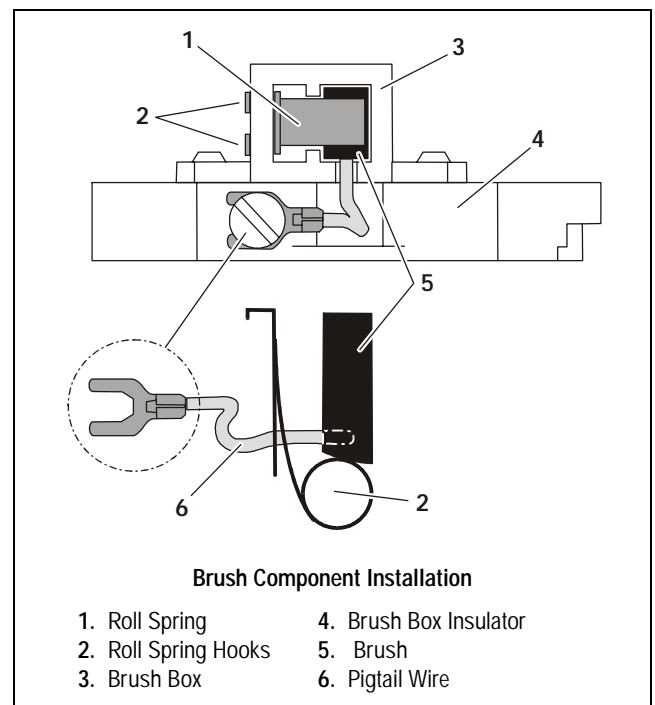

Brush Reassembly

**CAUTION**

MAKE CERTAIN THAT THE GROUND WIRE IS SECURELY RECONNECTED TO THE GROUND TERMINAL IF REMOVED. LEADS, INTERNAL TO THE SHIELD, MUST BE ROUTED AWAY FROM THE ARMATURE, (E.G.: BE CLOSE TO THE INSIDE WALL OF THE ALUMINUM SHIELD) TO PREVENT A SAFETY HAZARD AND/OR DAMAGE TO THE MOTOR.

1. Install the brush (*pig-tail*) terminal end under the screw on the brush box in the same manner as the old brush that was removed and tighten the screw.
2. Slide the body of the brush into the brush box, be certain that the wire (*pig-tail*) is aligned with the slot in the base of the brush box so that it can "feed" into the brush box slot as the brush wears down.

**NOTE:** *The pig-tail wire should be formed to rest against the nonmetallic insulator. It must be spaced from any metallic surfaces other than the brush box by a minimum of .125 in. (3mm).*

3. Now install the brush retaining spring bracket. Grasp the tip of the spring bracket such that the roll-type spring will be on the "brush side" of the brush box, and resting on top of the brush when the brush spring is completely installed.
4. Push the spring bracket slowly into it's slot while letting it's two attaching hooks slide on the wall of the brush box.
5. Stop, but do not release the spring bracket when it's hooks slip around the edge of the brush box.
6. While still grasping the spring bracket with the pliers, slowly bring the spring back out of the brush box until the hooks latch around the edge of the brush box.

7. Now release the spring bracket and check that it is lying flat against the brush box wall. If it is "cocked" it is improperly seated and will have to be reinstalled.

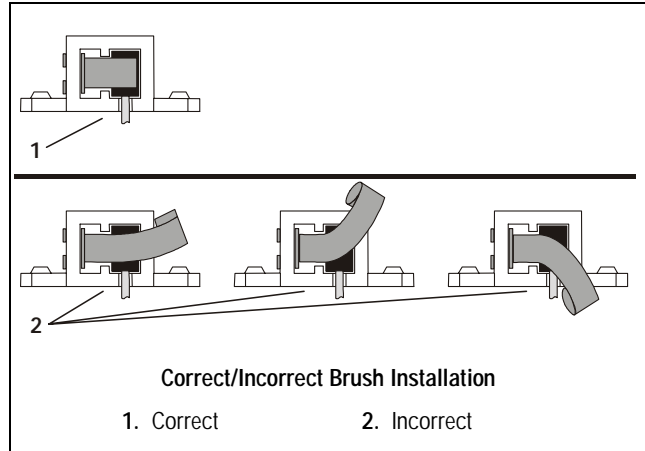

**IMPORTANT**

THE SPRING BRACKET MUST BE ALSO LIE COMPLETELY INSIDE THE BRUSH BOX AND NOT OUT OVER THE EDGE. THE ROLL END OF THE SPRING MUST BE CENTERED ON THE TOP OF THE BRUSH. (SEE CORRECT/INCORRECT BRUSH INSTALLATION ILLUSTRATION)

8. Also apply slight pressure by pulling up on the spring bracket to be certain it is hooked securely around the brush box wall at the bottom of the brush box.
9. Screw the brush caps back into the end shield using the largest possible screwdriver.
10. Reinstall the drive motor(s) to the machine and reconnect the power source.

**IMPORTANT**

NEW BRUSHES MAY BE SEATED BY RUNNING THE DRIVE MOTOR AT NO LOAD. PROPER SEATING IS REQUIRED FOR LOWEST BRUSH NOISE LEVEL.

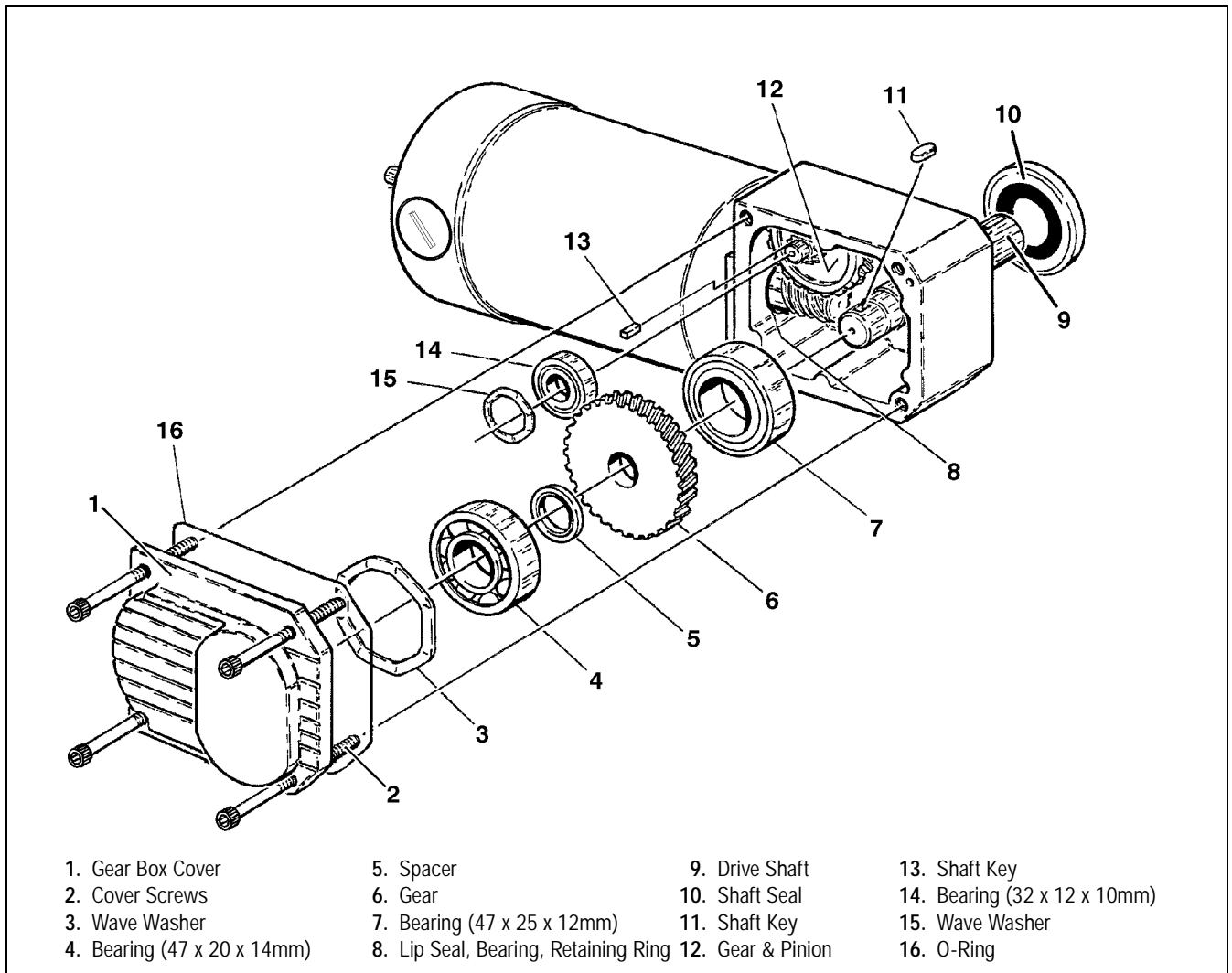

Figure 3-8. Drive Motor Gear Box Assembly - DVL/DVSP.

### Gear Box Disassembly/Assembly

(See Figure 3-8.)

The drive motor gear box is mounted on the rear of each drive motor. Transferring power from the electric drive motor to the rear drive wheels, the gear box is a right angle worm gear type with a 40:1 reduction drive ratio. The internal gears and bearings of the gear box are lubricated by 6 oz. (176cc) of gear oil in an unvented aluminum alloy housing. The following procedures disassemble and assemble the gear box housing internal components.

#### Gear Box Disassembly

1. Remove the drive motor/gear box/brake assembly from the machine using the procedure outlined previously in this section of the manual.
2. Remove the four (4) hex cap screws securing the side cover to the gear box housing, and remove the side cover and rubber seal ring. (Note: Early model machines did not have the rubber seal ring and were sealed with sealant only.) Be careful not to scratch or gouge the mating surfaces between the cover and the gear box housing. This area is sealed by the rubber ring/sealant and may leak oil if damaged.
3. Remove the wave washers from atop the large and small bearings and lay inside their respective holes in the side cover.

**NOTE:** The gear oil can be drained out when the side cover is removed in the next step. Remove the side cover from the gear box with the drive shaft side pointing down, then tilt drive motor/gear box assembly to drain the oil into a suitable container.

## SECTION 3 - BASE COMPONENTS

4. Using a suitable catch container, drain the gear oil from the gear box housing.
5. Remove the drive shaft assembly from the housing. Place the drive motor/gear box assembly on a hydraulic press with the open side of the gear box housing facing down. Support the gear box housing surface but do not block the free travel of the drive gear and bearings, on the drive shaft or the pinion gear assembly.
6. With the open surface of the housing properly supported, carefully press the drive shaft down through until it is free of the housing. When the drive shaft assembly is free, slide it completely out of the housing.
7. To remove the large (47mm) (*cover side*) bearing and (*housing side*) bearing from the drive shaft, use a suitable hydraulic press and press the bearing(s) off the shaft. Keep the spacer from between the cover side bearing and the drive shaft gear for reuse during assembly.
8. To remove the small (32mm) bearing(s) from the gear (*brass*) and pinion assembly, use a suitable hydraulic press and press the bearing(s) off the gear and pinion shaft.
9. To remove the (*brass*) worm gear from the pinion assembly, use a suitable hydraulic press and press the gear off the pinion shaft. Keep the (*brass*) gear key for reuse during assembly.
10. Inspect the drive shaft seal for cuts, cracks and wear, or if showing signs of leakage. Replace if necessary.

### Gear/Pinion Shaft Assembly

11. Locate the pinion gear/shaft, place the key for the (*brass*) worm gear into the slot on the gear shaft.
12. Press the (*brass*) worm gear onto the pinion shaft and align the keyway in the (*brass*) worm gear with the key on the pinion shaft. Press the (*brass*) worm gear onto the shaft until it bottoms out against the pinion gear teeth.

**NOTE:** Press bearings onto the shaft pressing only against the bearing inner race. Do not press against the outer race or damage could occur to the bearing.

13. Press the small (32mm) bearings onto the ends of the pinion shaft. The inner race of the bearing on the pinion gear side can be bottomed out against the pinion gear. Do not press the bearing on the (*brass*) worm gear side of the shaft in tight against the (*brass*) worm gear. This bearing must be flush with the end of the shaft on the outside, yet have clearance from the (*brass*) worm gear on the inside, so it can rotate freely.

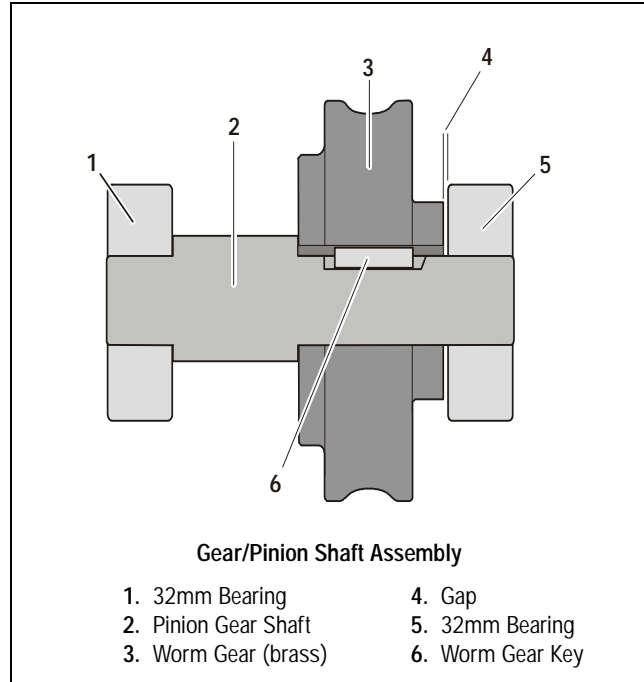

### Drive Shaft Assembly

1. Slide the (*housing side*), 42mm x 25mm x 12mm (*thinner*) bearing onto the long end of the drive shaft. Press the bearing inner race until it bottoms against the shaft shoulder between the drive gear and the bearing.
2. Slide the narrow spacer onto the drive gear end of the shaft and press the (*cover side*) 42mm x 20mm x 14mm (*wider*) bearing onto the drive shaft until it bottoms against the spacer. This bearing should be flush with the end of the drive shaft.



**Final Gear Box Assembly**

1. If necessary, install a new drive shaft lip seal into the drive shaft hole in the gear box housing before assembling the drive shaft gear set into the gear box. Install the seal so it is even with the bottom of the chamfer in the drive shaft hole on the outside of the housing and flush with the bearing seat on the inside of the housing.
2. Lube the drive shaft seal with a thin film of oil before sliding the drive shaft over the seal.
3. Position the gear box with open cover side up, allow space under the gear box for the drive shaft to extend through without obstruction.
4. Hold the gear and pinion, and drive shaft assemblies together with the pinion gear and the ring gear on the drive shaft meshing. Now carefully slide these assemblies into the gear box housing sliding the drive shaft through the drive shaft lip seal.

**NOTE:** While assembling the gear assemblies into the gear box housing, be careful with the drive shaft seal and the softer brass worm gear and brass drive worm gear from the drive motor.

5. Continue to drop the gear assemblies into the gear box, align the bearings with the bearing seats in the

housing on both assemblies. Drop the gear and pinion (*smaller*) bearing into its seat first, while wiggling that gear set align the drive shaft bearing and wiggle it into its seat. When both are seated continue to next step.

6. With the gear box still positioned with the open cover side up, fill the gear box with six (6) ounces (U.S.) (175cc's) of good quality worm gear oil (*Specification - SAE 90 weight - AGMA#5 - EP Compounded*). When pouring the gear oil, wet the gears and bearings with the oil.
7. Wet with gear oil and place the large wave washer on the end of the drive shaft bearing and the small wave washer on the end of the gear and pinion bearing.
8. Clean the mating surfaces of the side cover and the gear box and check that the cover dow guide pins are properly installed in the cover.
9. Insert the rubber seal into the groove in the cover.
10. Using the cover dow guide pins, place the cover onto the gear box housing.
11. Secure using the four (4) hex cap screws, torque screws evenly to 90 in. lbs.
12. Install the drive motor back onto the machine.

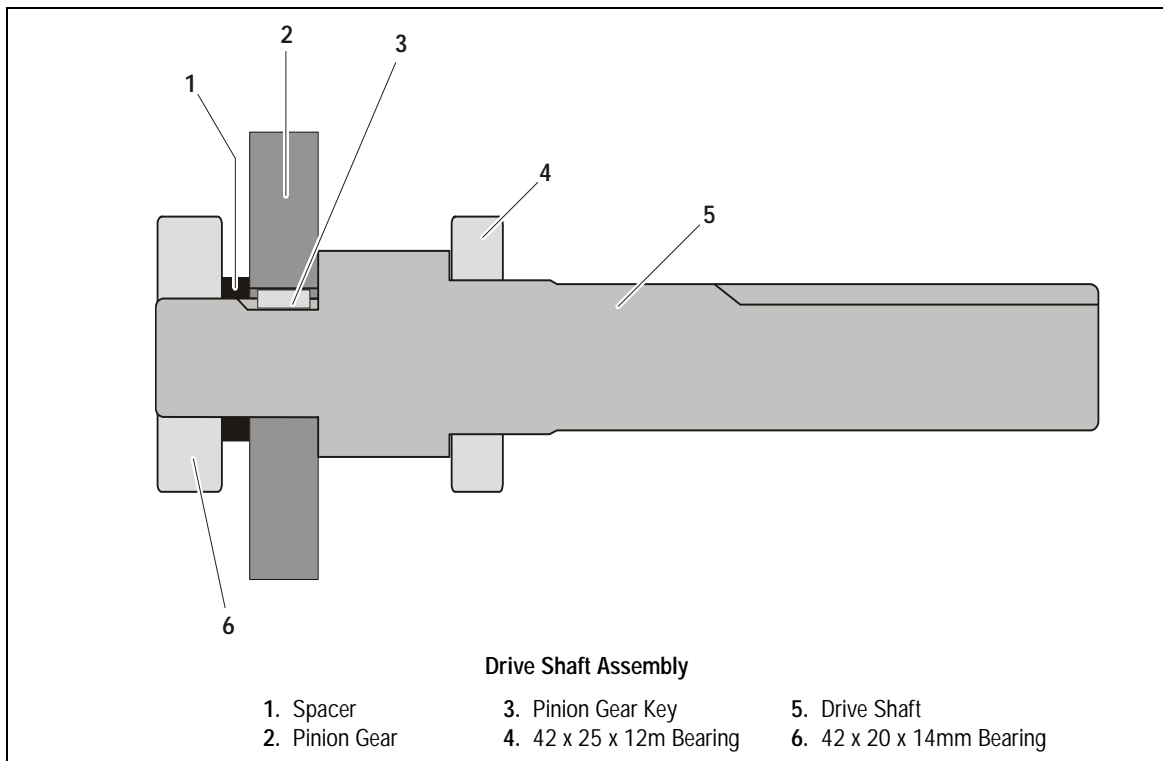

3.6 POT HOLE PROTECTION SYSTEM

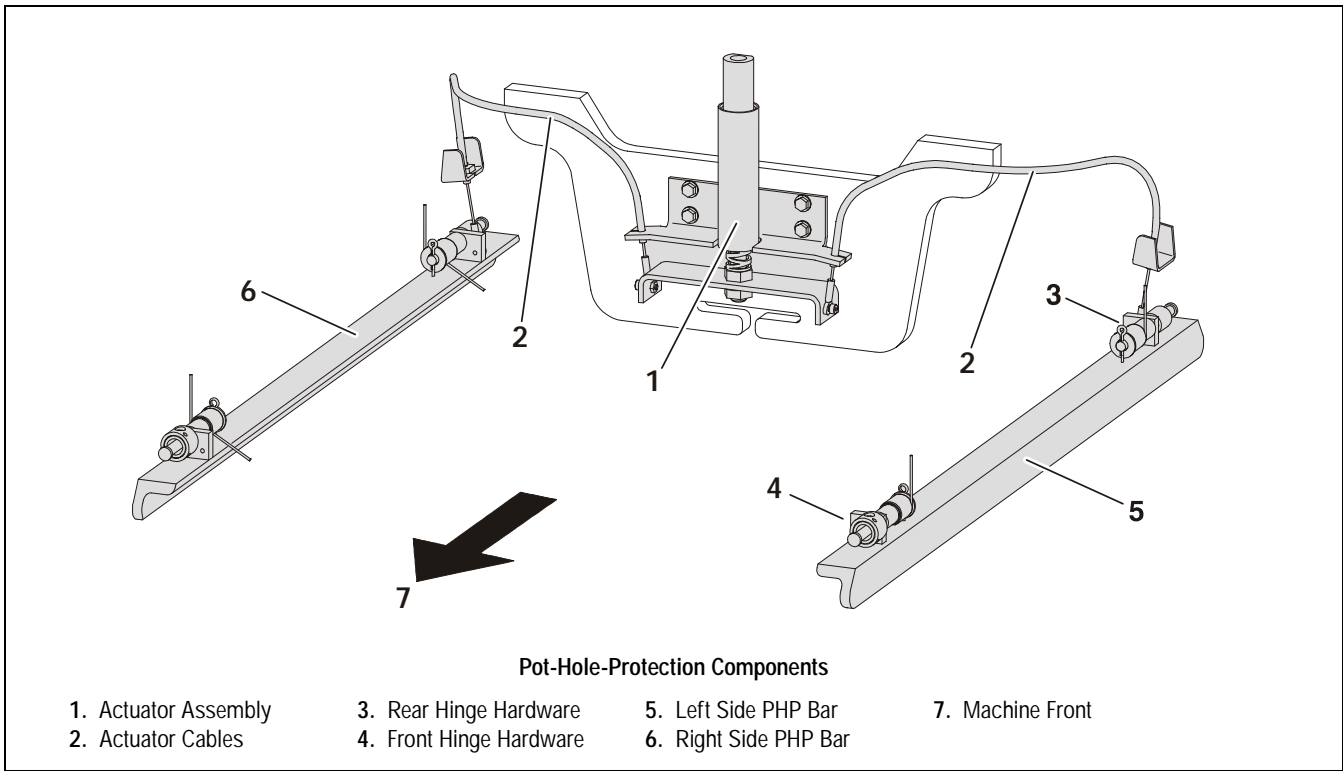
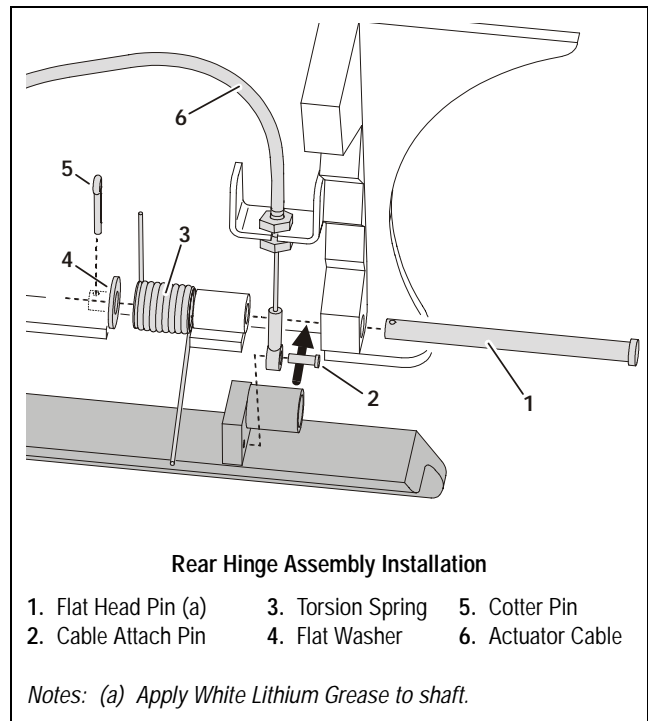
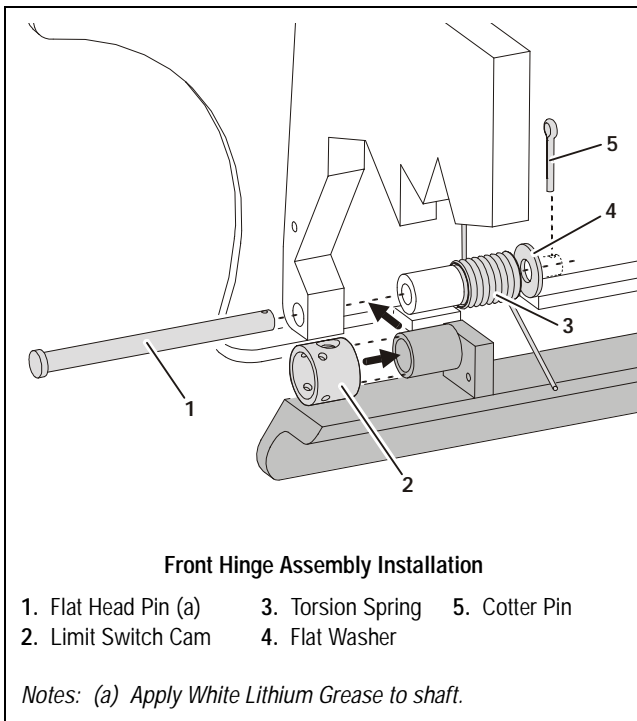
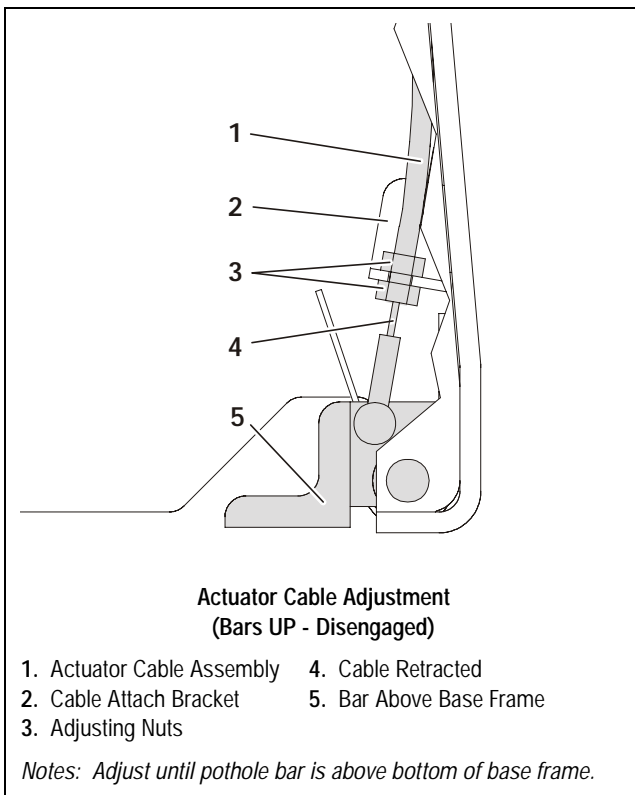
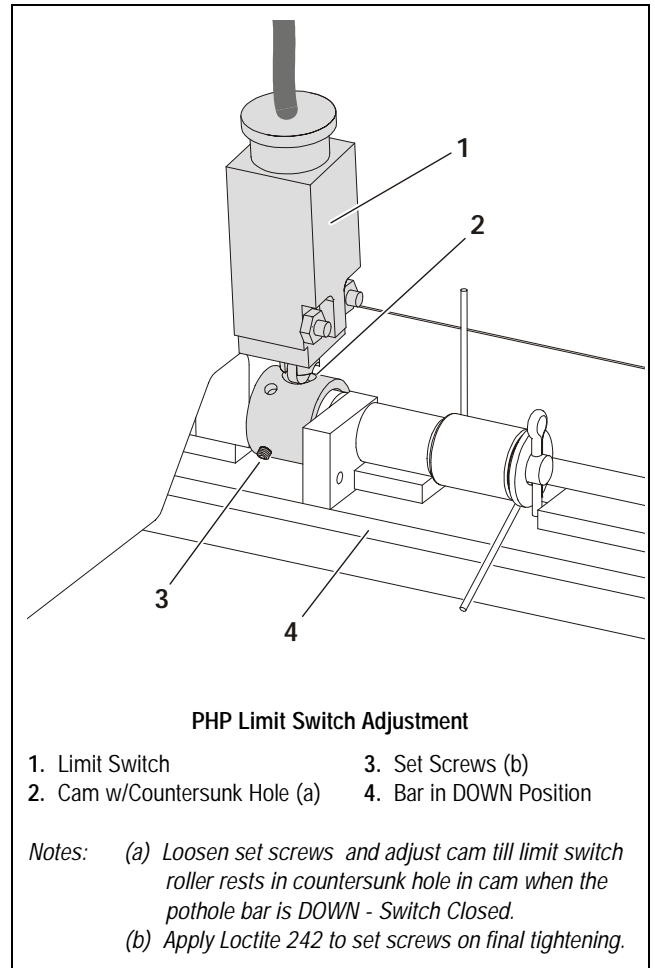
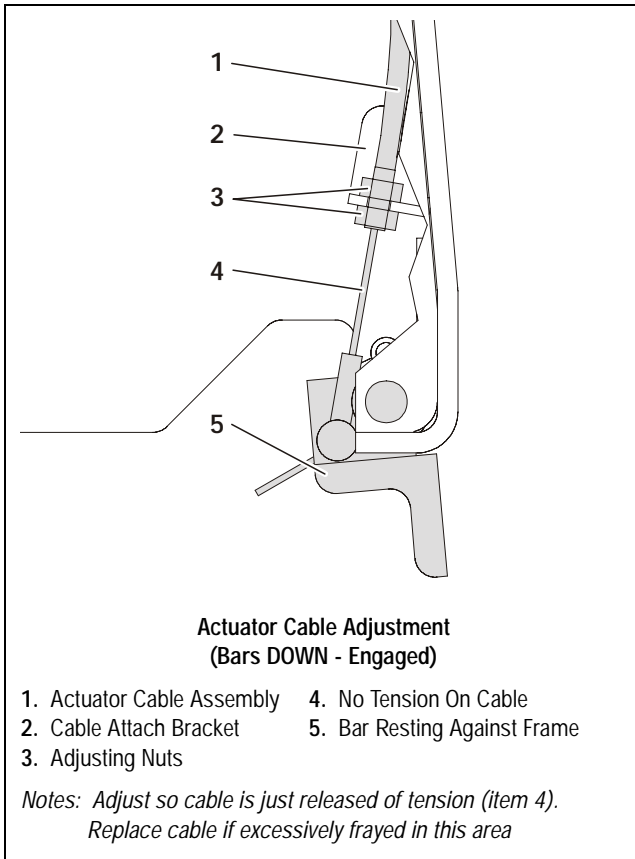

Figure 3-9. Pot-Hole-Protection System Components.





### 3.7 BATTERY/BATTERY CHARGER - SERVICE PROCEDURES

#### Battery Low Voltage Warning Indicators

The Platform Control Console and Ground Control Station indicate battery low voltage at three (3) Warning Levels.

Table 3-1. Battery Low Voltage Warning Indicators.

**IMPORTANT:** The 3 Levels of Battery Low Voltage Warning indication will only activate on DVL/DVSP machines with version 29 or later Ground Control Module software (implemented 8/2004). However, machines with earlier versions of software must follow the same LED/BAR indicator guidelines and battery charging cycles to maximize battery life.

WARNING LEVEL	INDICATOR LOCATION		RESULT	ACTION REQUIRED TO CLEAR FAULT
	PLATFORM CONTROL LED	GROUND CONTROL LCD		
LEVEL-1			<ul style="list-style-type: none"> <li>• 3 LEDs/BARS Flashing with an audible beep.</li> <li>• Machine will Operate - No Control Functions Locked Out.</li> </ul>	Charge batteries to a level of four (4) LEDs/BARS or more before operating.
LEVEL-2			<ul style="list-style-type: none"> <li>• 2 LEDs/BARS Flashing with an audible beep.</li> <li>• Platform Lift-UP Function is Locked Out.</li> </ul>	Charge batteries for a minimum of four (4) continuous hours or eight (8) LEDs/BARS lit before operating. (a)
LEVEL-3			<ul style="list-style-type: none"> <li>• 1 LED/BAR Flashing with an audible beep.</li> <li>• Drive and Platform Lift-UP Functions Locked Out.</li> </ul>	Charge batteries for a minimum of four (4) continuous hours or eight (8) LEDs/BARS lit before operating. (a)

**NOTE:** (a) To maximize battery life, it is recommended that the factory supplied batteries be charged continuously for a minimum of 4 hours or until 8 bars are lit on the ground station LCD Display before operating the machine. When drained to Warning Level 2 or 3, batteries must be charged until 8 bars are lit on the ground station LCD display to clear the fault code.

#### Diagnosics

Continued operation of the machine in a low voltage state will damage (sulfate) the batteries. Eventually this will cause shorter cycle times before recharge is needed as well as progressively shorter charging time before 100% charge complete light illuminates.

1. If the cycle time of your machine becomes drastically reduced try the following solutions:
  - a. Cycling the battery charger several times after the green light comes on will break through most sulfated batteries. Do this by plugging the charger into the proper receptacle and charging until a full charge is indicated. After a full charge is indicated unplug the battery charger and plug it in again. Repeat this procedure several times.
  - b. Remove the batteries and place them, individually, on a 12 volt automotive type charger that

supplies a constant high current. This should overcome any sulfated batteries.

**NOTE:** When battery voltage becomes too low the machine will begin to pull to the left when driven.

#### Battery Condition Testing

**NOTE:** Batteries in storage should be kept at 12.5V or higher.

Clean batteries terminals, using a non-metallic brush and a solution of baking soda and water. Rinse with clean water. After cleaning, thoroughly dry batteries and coat battery terminals with an anti-corrosion compound.

Before testing for battery condition, the open circuit voltage should be taken from each battery. If the voltage of the batteries differs by 0.3 volts or more, the lower voltage battery should be replaced.

**Battery Testing Can Be Performed In Two Ways:**

1. The batteries can be tested using a battery tester capable of testing 12V 100Ah AGM VRLA (*Valve Regulated Lead Acid*) batteries, using the instructions of the battery tester manufacturer.
2. If an appropriate battery tester is unavailable, the batteries can be tested by fully charging them with the charger that is installed in the machine. Then check the battery voltage of each battery - 4 hours - after charging is complete. Batteries less than 12.72 volts should be replaced.

**NOTE:** *If a faulty charger is suspected, the batteries can be charged using a charger that supplies 2.45 volts/cell. Charging should be terminated when the charge current drops below 1 amp.*

**Battery Replacement**

Replacement battery(s) must be of equivalent voltage and amperage output as the OEM battery(s) in order for the machine to operate to as manufactured specifications. Battery replacement part weight must also be 65 lb. (30Kg) in order to maintain machine stability as manufactured.

**⚠ WARNING**

**DO NOT REPLACE ITEMS CRITICAL TO STABILITY, SUCH AS BATTERIES, WITH ITEMS OF DIFFERENT WEIGHT OR SPECIFICATION. DO NOT MODIFY UNIT IN ANY WAY TO AFFECT STABILITY.**

**Battery Charger General Information****IMPORTANT**

**DO NOT ATTEMPT TO DISASSEMBLE THE BATTERY CHARGER IF MACHINE IS STILL UNDER WARRANTY. OPENING THE BATTERY CHARGER WHILE THE MACHINE IS UNDER WARRANTY WILL VOID THE CHARGER WARRANTY. IF UNDER WARRANTY REQUEST A REPLACEMENT CHARGER FROM THE FACTORY.**

**ALSO BEFORE REPLACING ANY COMPONENT, USE THE CHARGER MANUFACTURERS TROUBLESHOOTING GUIDE SHIPPED WITH THE MACHINE TO CHECK THE INTERNAL AC AND DC CIRCUITS AND DETERMINE WHICH COMPONENT HAS FAILED. A WIRING DIAGRAM FOR THIS MODEL DUAL VOLTAGE-SCR CHARGER IS INCLUDED AT THE END OF THIS SECTION OF THE MANUAL, SEE FIGURE 3-10.**

The DVL and DVSP battery charger allows for replacement of the following internal components. Consult your Illustrated Parts Manual for part numbers of these components which are available from the JLG Parts Department:

- Transformer
- Printed Circuit Board
- Shunt Assembly
- Interlock Relay
- SCR Rectifier
- AC Circuit Breaker
- DC Circuit Breaker
- AC Voltage Selector Switch
- Wet/VRLA Charging Profile Selector Switch

Replacement and troubleshooting of these components requires removal of the battery charger from its mounting position on the machine.

**Battery Charger Troubleshooting**

If batteries are not charging properly use the following steps to assist in resolving the problem.

1. Be sure the charger is plugged into the proper receptacle and there is power to that receptacle.
2. Be sure all battery connections are tight.
3. If charger does not come on, check connections at the charger. Make sure all connections are tight.
4. If charging over night, ensure there is power to the receptacle at all times and not being turned off at the end of the shift.

**Battery Charge/Flash Code LED Indicator on Platform Control Console**

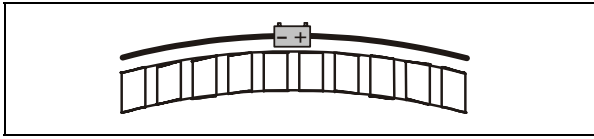

**NOTE:** Normal battery charging will occur with a voltage reading as low as .24V.

On normal power-up and operation this series of LEDs visually indicates the amount of charge left in the batteries.

- (+) GREEN LEDs lit indicate maximum charge.
- (-) RED LED's lit indicate minimum charge remaining.
- The number of LEDs lit will change depending on the level of charge in the batteries.

If battery voltage falls below 16.8 volts a fault condition will occur and the machine will stop operating. The batteries will need recharged.

**Battery Charging Status Indicators Mounted on Ground Control Station Cover**

The battery charging status indicators are mounted just above the Charger AC input receptacle on the center cover section at the rear of the machine.

When first plugged in, the charger runs through a self-diagnostic test, lighting the LEDs in sequence, then charging will begin. The following descriptions indicate charging status after diagnostic test is complete.

**NOTE:** Be sure batteries are fully charged before disconnecting the battery charger. Failure to do so will result in reduced battery life.

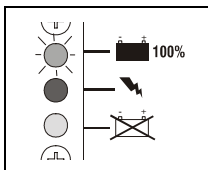

**CHARGE COMPLETE**  
GREEN (TOP) LED ON  
100% Complete

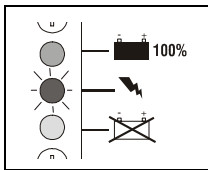

**CHARGING**  
AMBER (MIDDLE) LED ON  
Charge Incomplete

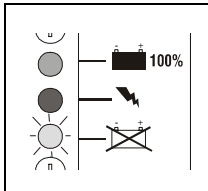

**CHARGING PROBLEM**  
RED (BOTTOM) LED ON  
Consult Troubleshooting Section of the Service Manual or the Charger SCR Manual in Manual Storage Box.

**Wet/VRLA Battery - Charging Profile Switch**

The DVL and DVSP battery charger is equipped with a manually selectable charge profile switch, located on the rear panel. This switch must be set properly to select the charging profile required for either **WET** gassing lead acid batteries or **VRLA** - Valve Regulated Lead Acid, gelled/agm type lead acid batteries.

The machine is equipped from the factory with VRLA - valve regulated lead acid batteries, and the switch is set from the factory to **VRLA**. If the factory batteries are replaced with wet gassing batteries, set this switch to **WET**.

**IMPORTANT**

**AN IMPROPER PROFILE SETTING MAY DAMAGE THE BATTERIES AND SHORTEN THE BATTERY'S LIFE.**

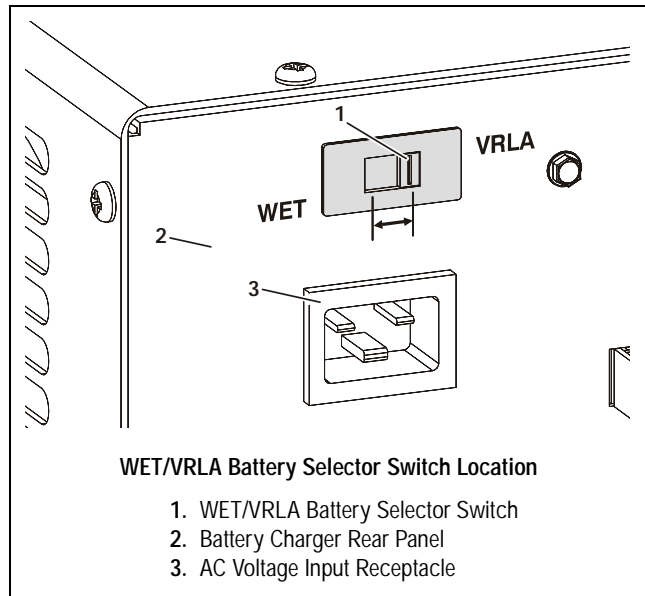

**General Component Installation Notes**

When removing components make note of the wiring connections before disconnecting the wiring between the components within the charger assembly. Only disconnect enough wiring to remove a component.

The battery charger manual supplied with the machine contains a wiring diagram for the charger as well as Figure 3-10. at the end of this section of the manual.

**Battery Charger Installation**

1. Disconnect the positive (+) battery cable from the left side battery.
2. Carefully raise the lift to gain access to the underside of the base frame. Refer to "Positioning Lift For Access to Components Located Under the Base Frame" in Section 2.
3. Disconnect the wiring connectors from the back of the charger assembly.
4. Remove the four (4) capscrews and washers securing the charger to the base frame on the front of the charger.
5. Swing the front tie down lug up and remove the charger from the machine and place on a suitable work bench for disassembly.

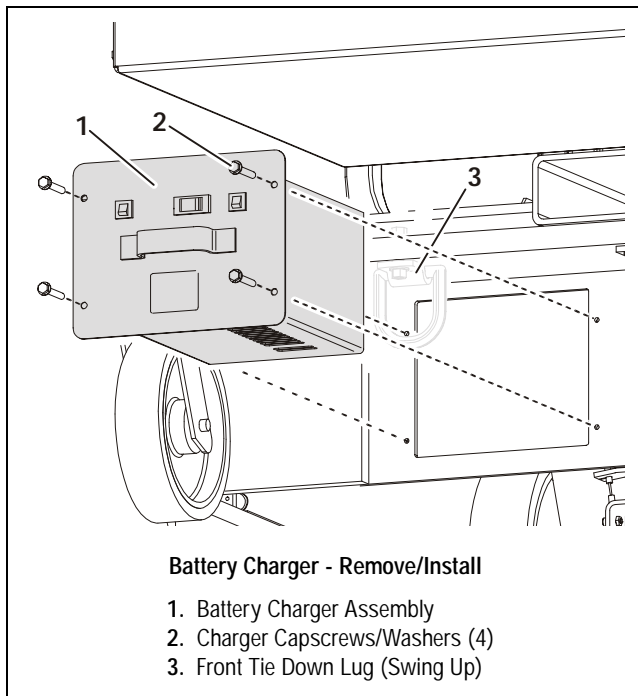

**Battery Charger - Remove/Install**

1. Battery Charger Assembly
2. Charger Capscrews/Washers (4)
3. Front Tie Down Lug (Swing Up)

**Cover Installation**

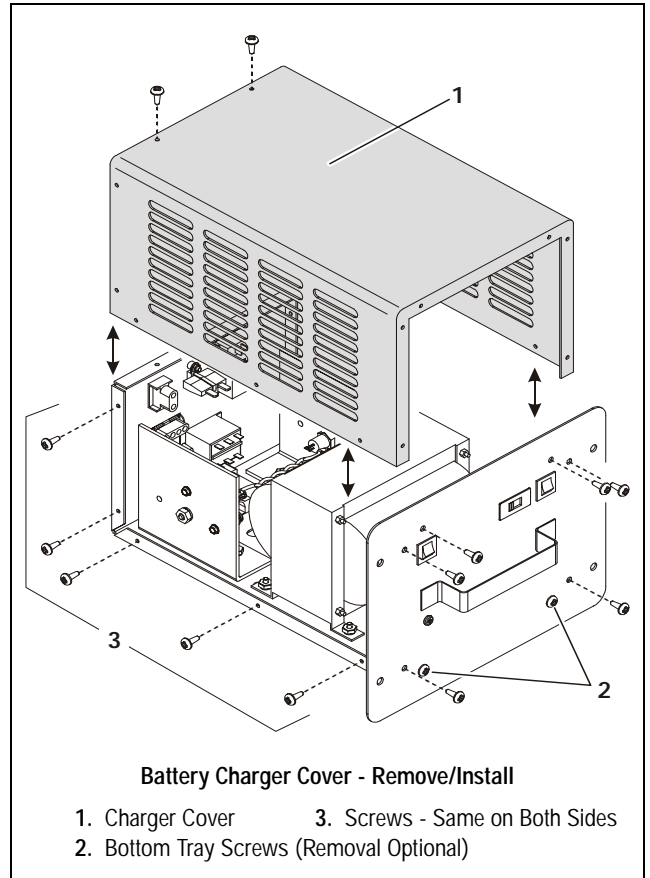

**Battery Charger Cover - Remove/Install**

1. Charger Cover
2. Bottom Tray Screws (Removal Optional)
3. Screws - Same on Both Sides

**AC Line Fuse Installation**

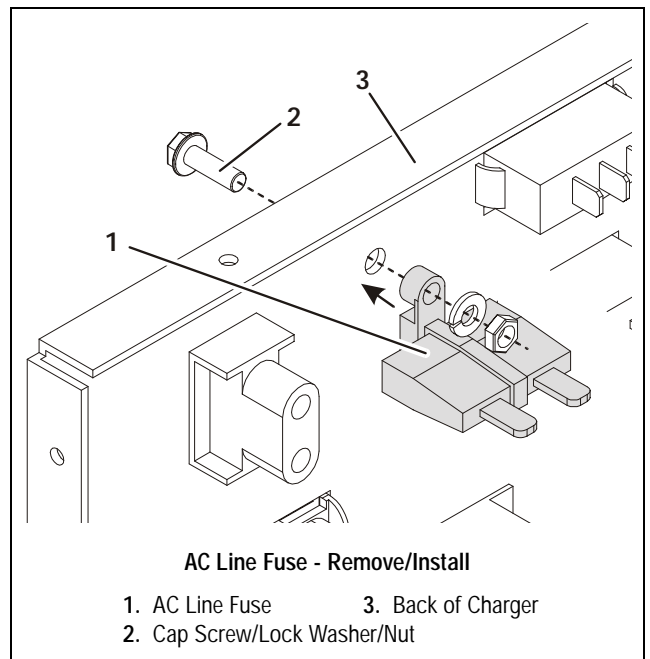

**AC Line Fuse - Remove/Install**

1. AC Line Fuse
2. Cap Screw/Lock Washer/Nut
3. Back of Charger

## SECTION 3 - BASE COMPONENTS

### Interlock Relay Installation

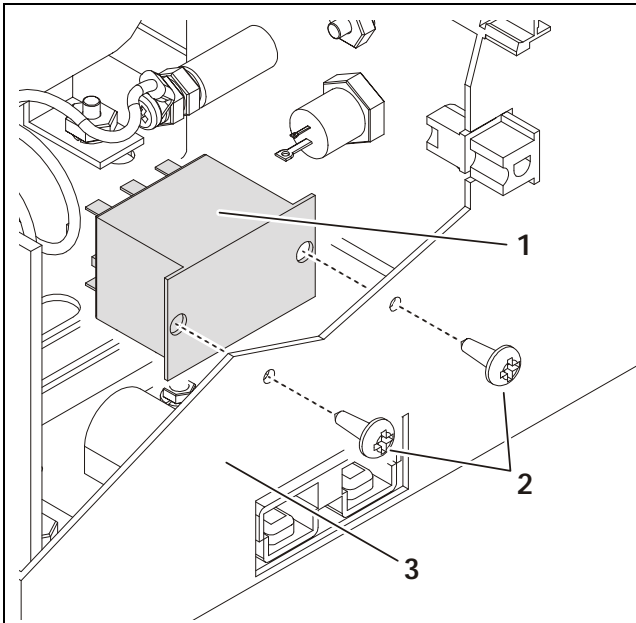

**Interlock Relay - Remove/Install**

- 1. Interlock Relay
- 2. Attach Screws (2)
- 3. Back of Charger

### Shunt Assembly Installation

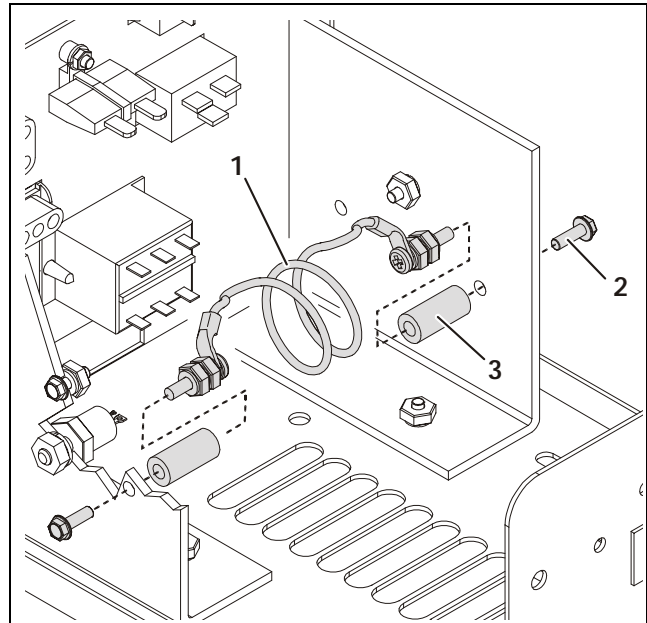

**Shunt Assembly - Remove/Install**

- 1. Shunt Assembly
- 2. Cap Screws (2)
- 3. Spacers (2)

### Wet/VRLA Switch Installation

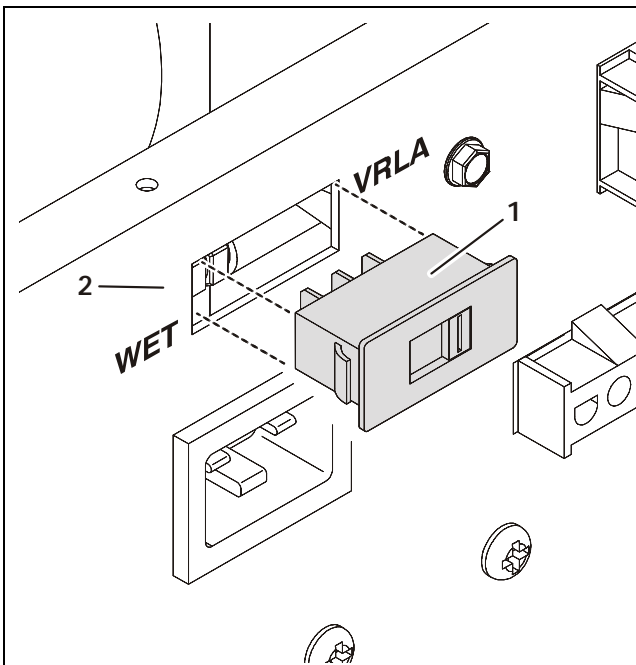

**Wet/VRLA Switch - Remove/Install**

- 1. Wet/VRLA Switch
- 2. Back of Charger

### SCR Rectifier Installation (Either Side)

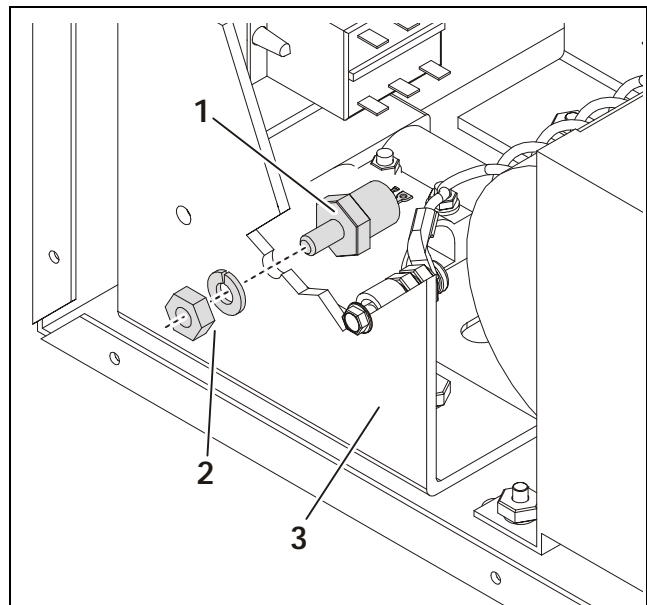

**SCR Rectifier - Remove/Install  
(Same Mounting on Both Sides)**

- 1. SCR Rectifier
- 2. Nut/Lock Washer
- 3. Aluminum Mount Plate



**Transformer Installation**

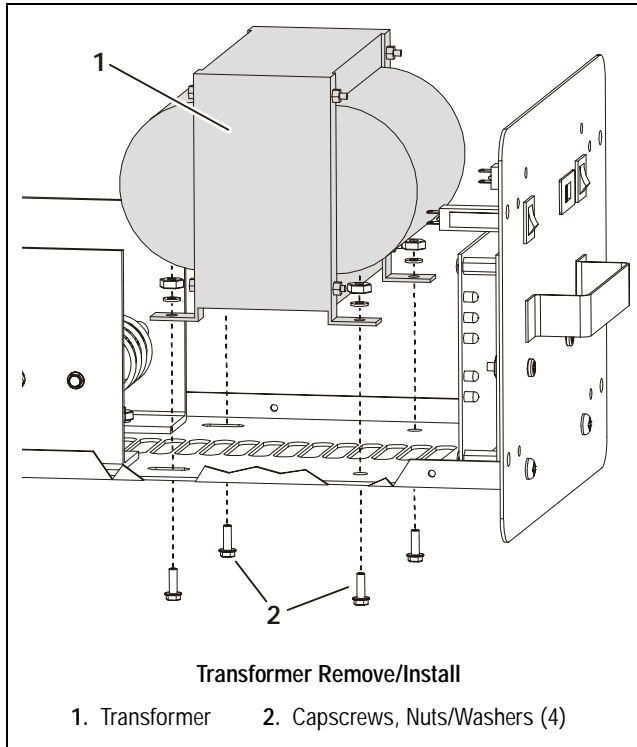

**DC Circuit Breaker/Voltage Select Switch Installation**

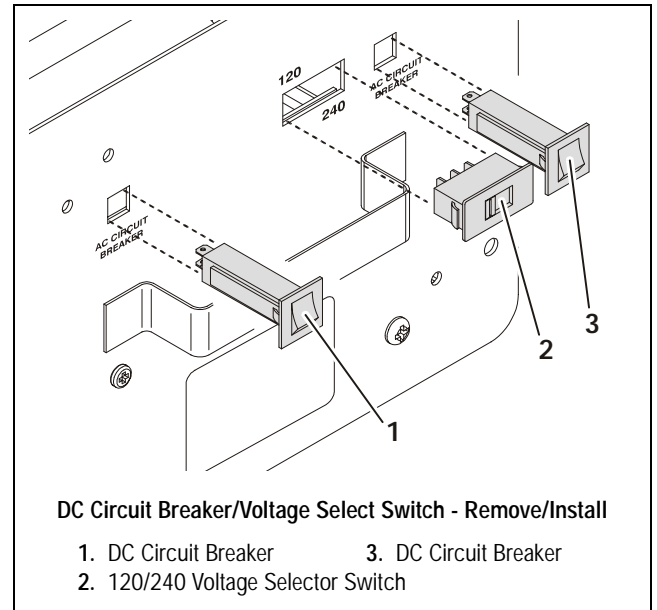

**Printed Circuit Board Installation**

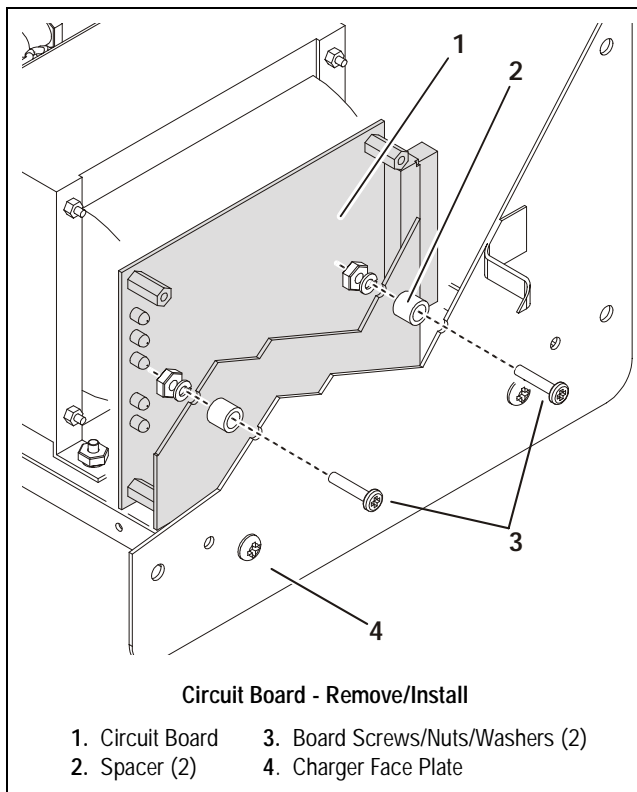

SECTION 3 - BASE COMPONENTS

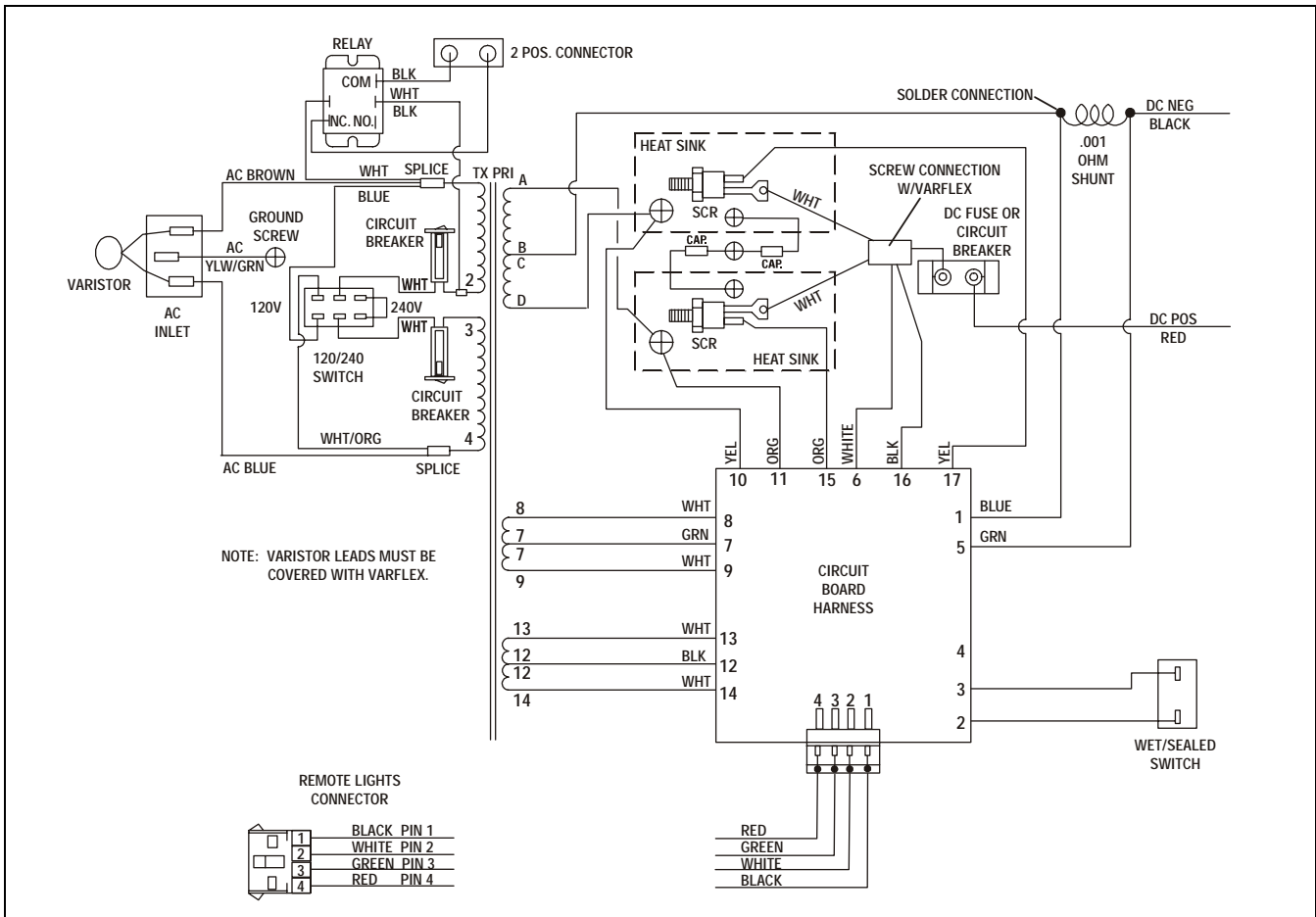

Figure 3-10. DVL/DVSP - SCR Dual Voltage - Battery Charger Wiring Diagram.

SECTION 4. CONTROL COMPONENTS

4.1 CONTROL COMPONENTS OVERVIEW

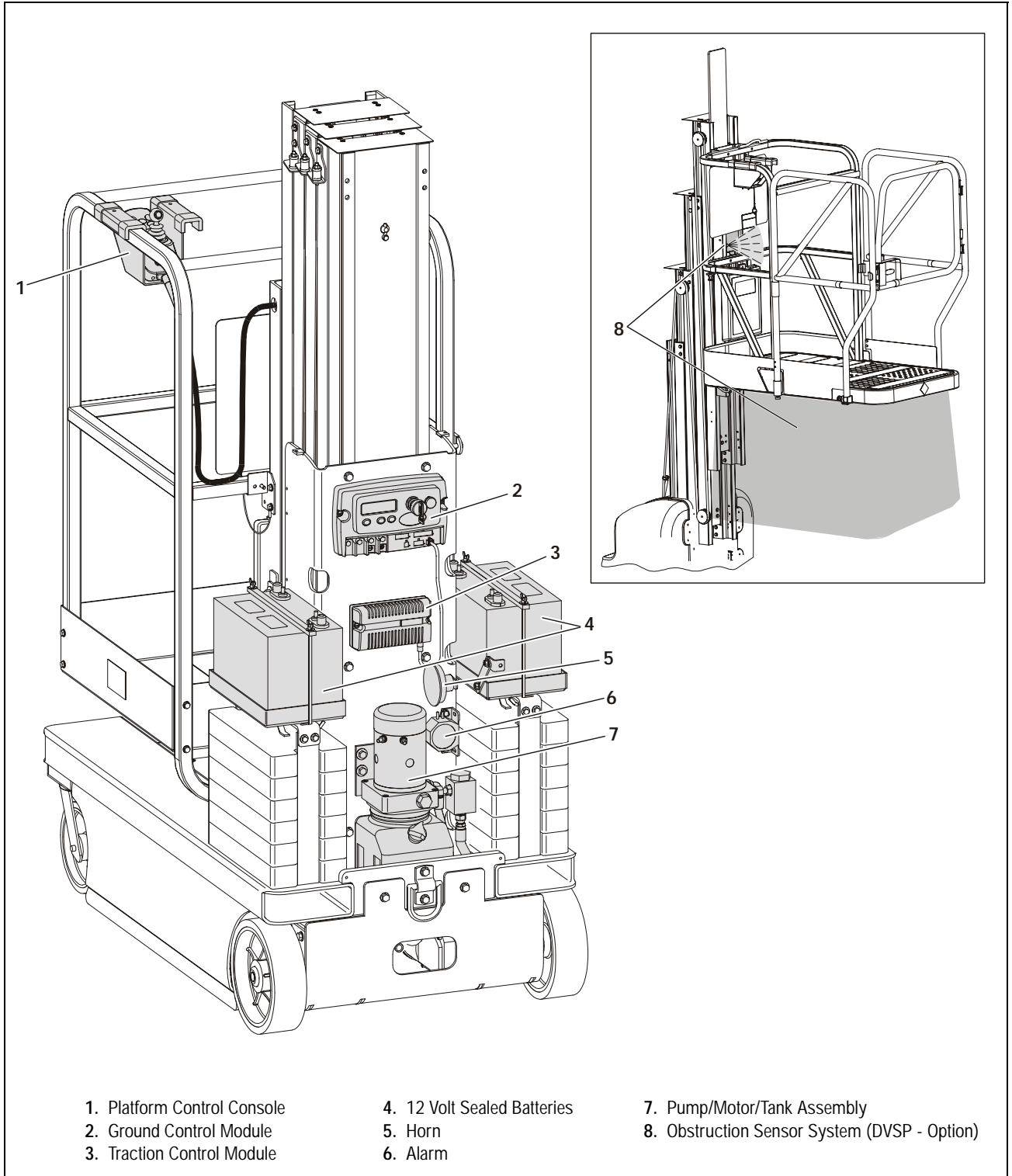
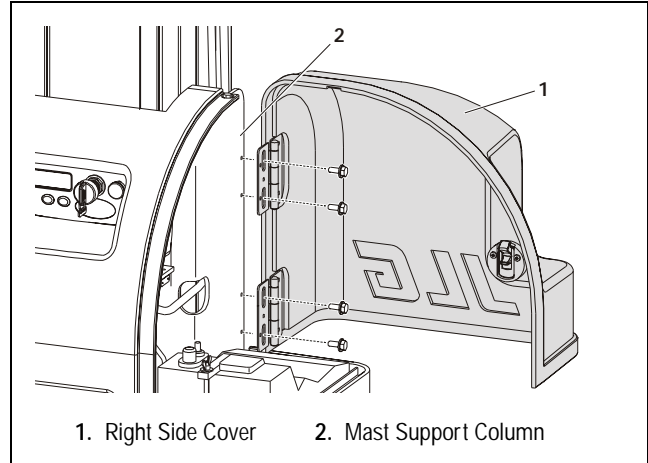
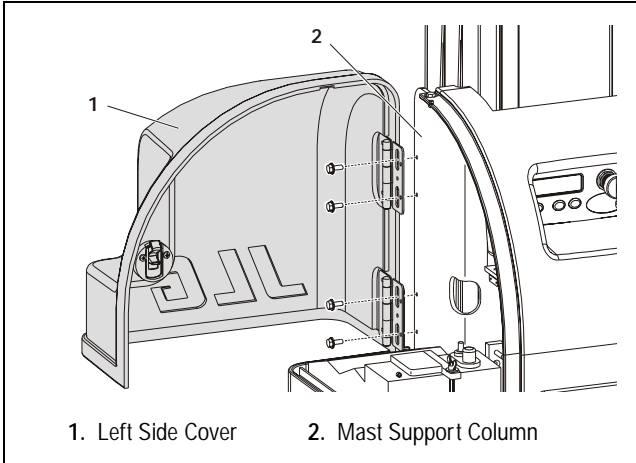

Figure 4-1. Control Components Location - DVL/DVSP.

## SECTION 4 - CONTROL COMPONENTS

### 4.2 CONTROLS COVER INSTALLATION

#### Battery Cover Doors



#### Center, Left and Right Lower Covers

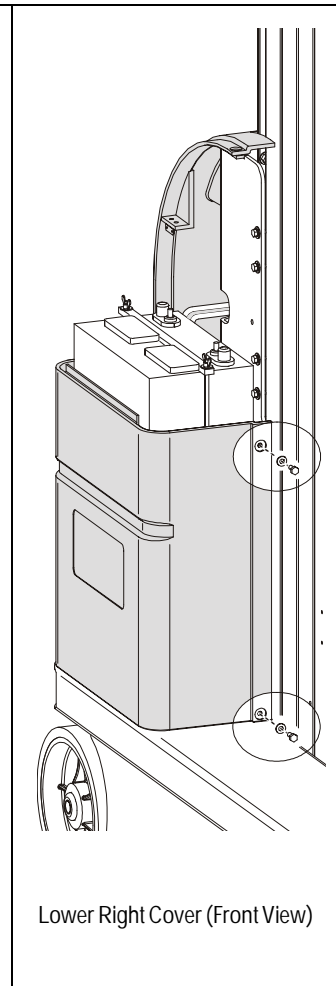
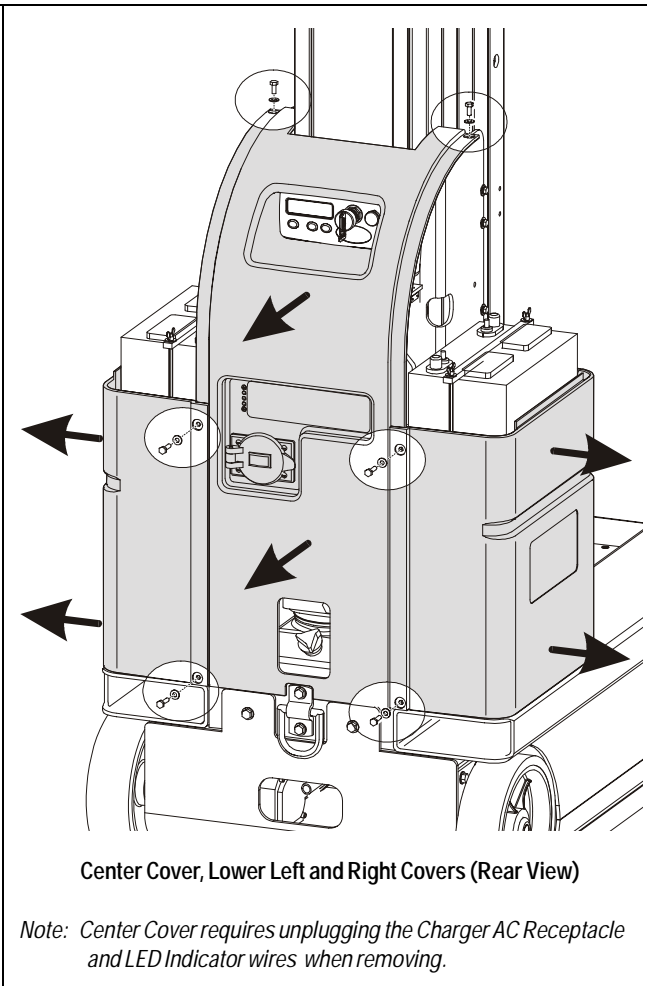
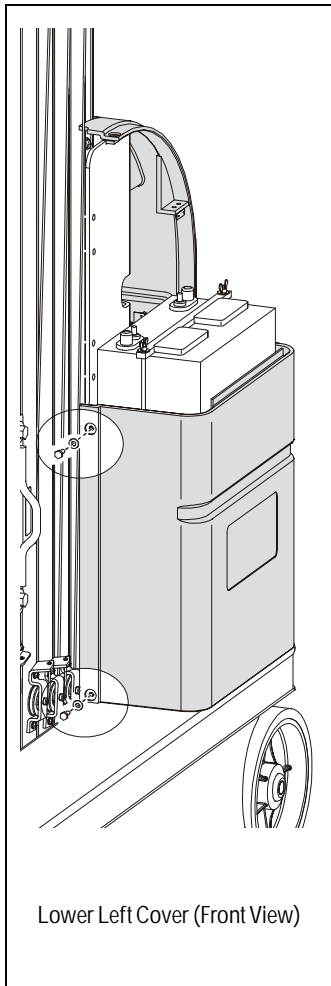

**4.3 CONTROL COMPONENTS - INSTALLATION**

**IMPORTANT**

BEFORE REMOVING ANY COMPONENT FROM THE ELECTRICAL SYSTEM, DISCONNECT THE POSITIVE TERMINAL FROM THE LEFT SIDE BATTERY.

**Ground Control Module**

The Ground Control Module is located under the center cover at the rear of the machine and is mounted on the mast support column. All electrical components on the machine operate directly or indirectly through the Ground Control Module. The module is currently programmed at the factory with the machines operating profile. If replacing a Ground Control Module the new module may require some programming to enable any optional equipment. See Section 4.5, Ground Control Module - Programming.

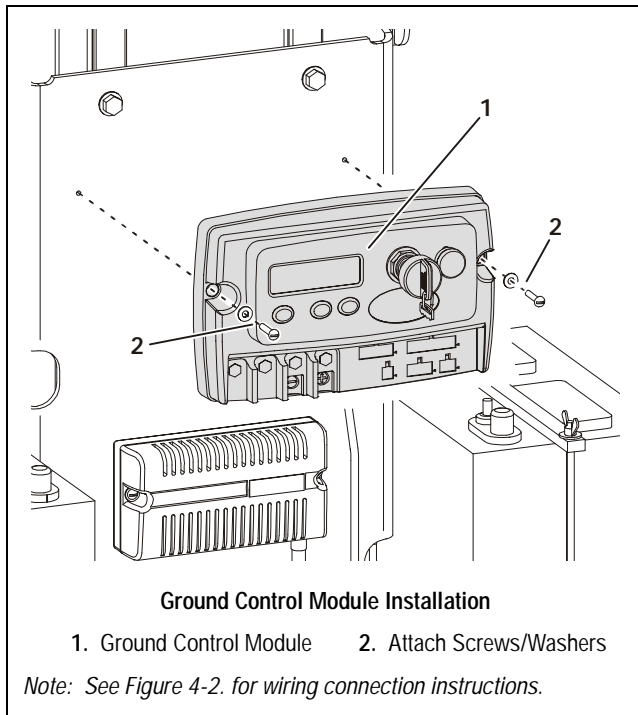

**Traction Control Module**

The Traction Control Module is mounted below the Ground Control Module on the mast support column.

This module controls the voltage to the drive motors as regulated by the Ground Control Module from signals received from the Joystick Controller located on the Platform Control Module.

There are no internal parts serviced on this module.

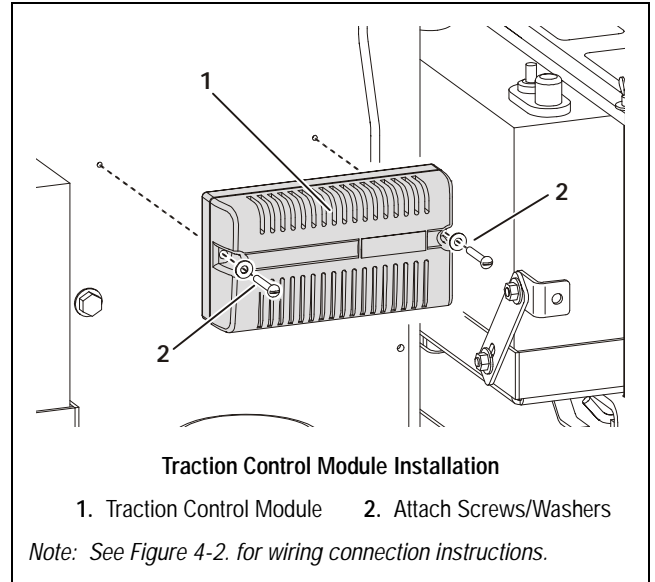

**Platform Control Console Installation**

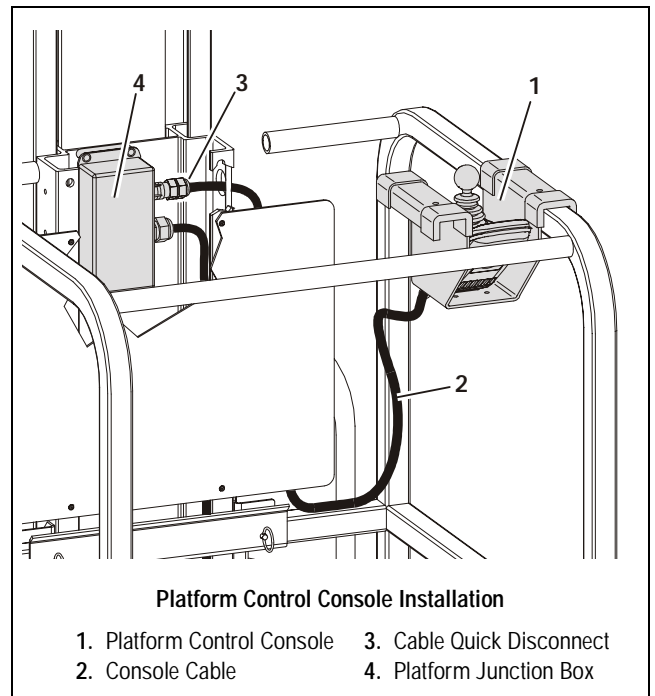

## SECTION 4 - CONTROL COMPONENTS

### Battery Installation

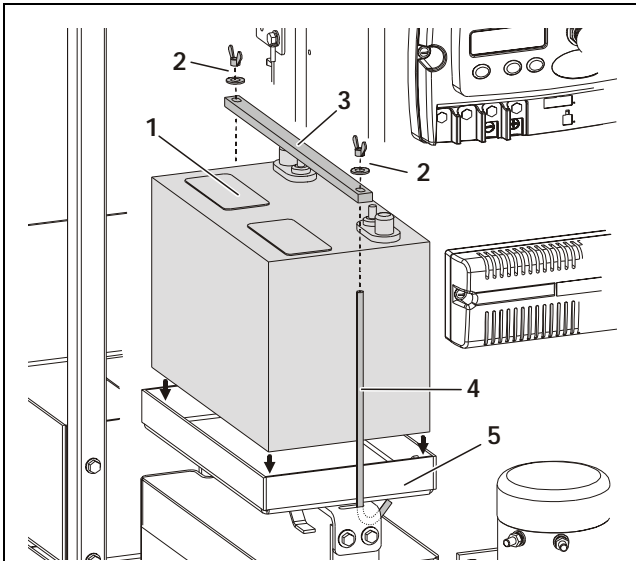

#### Battery Installation

1. Battery
2. Wing Nut/Washer
3. Cross Bar
4. J-Hook - Hold Down Rod
5. Battery Tray

Note: See Figure 4-2. for wiring connection instructions.  
Installation same for either side battery.

### Alarm Installation

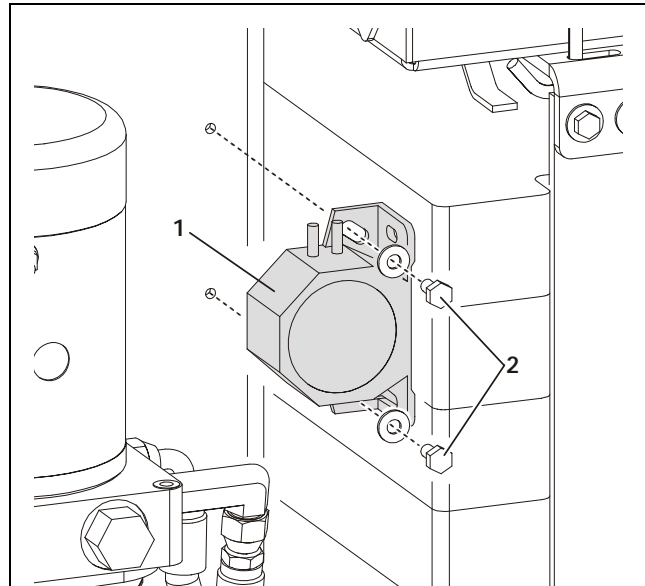

#### Alarm Installation

1. Alarm Assembly
2. Attach Screws/Washers

Note: See Figure 4-2. for wiring connection instructions.

### Horn Installation

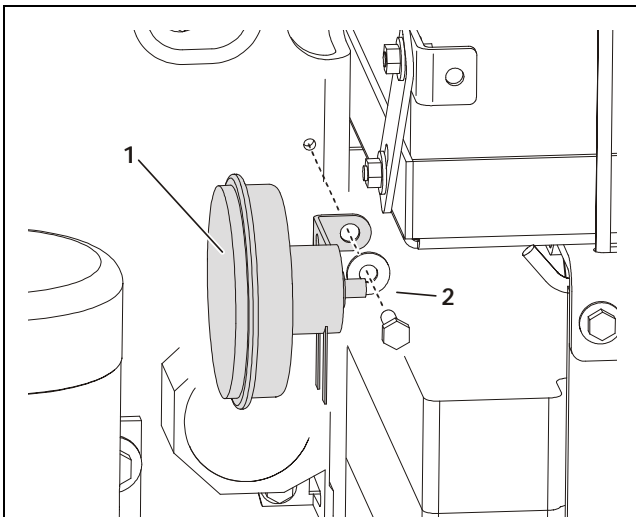

#### Horn Installation

1. Horn Assembly
2. Attach Screws/Washers

Note: See Figure 4-2. for wiring connection instructions.

**Battery Installation (EE Spec Machines Only)**

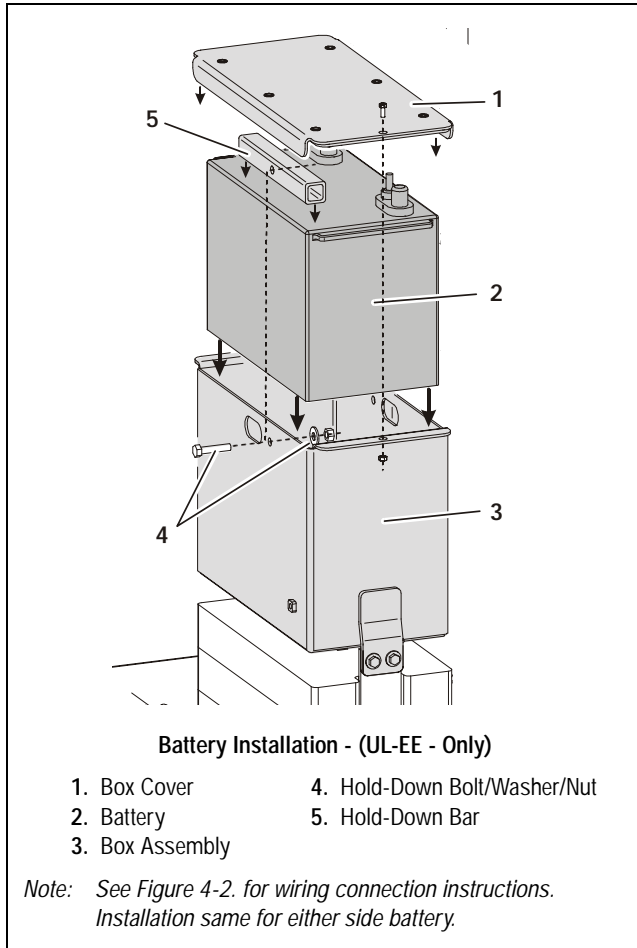

**Master Disconnect Switch - (EE Spec Machines Only)**

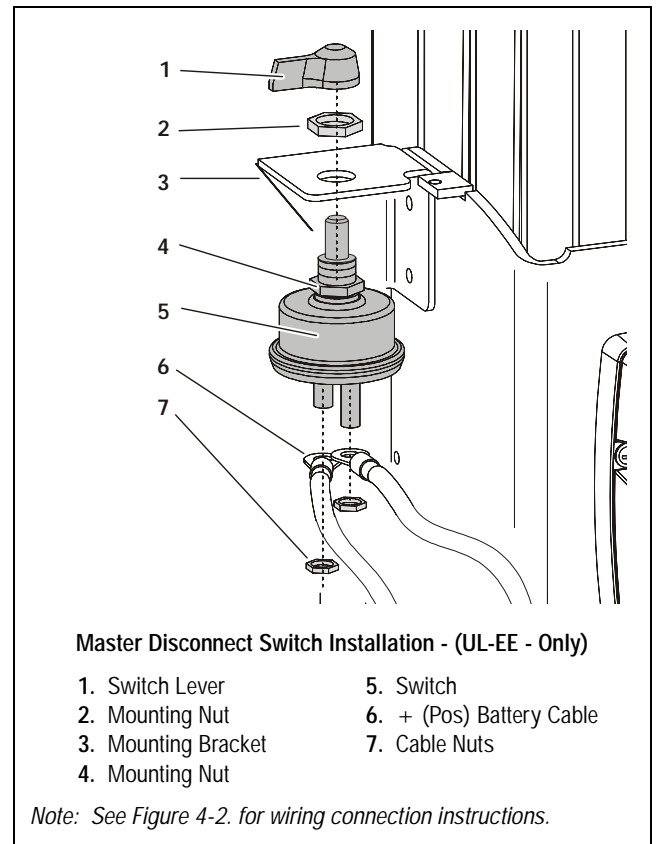

**Fuse Box - (EE Spec Machines Only)**

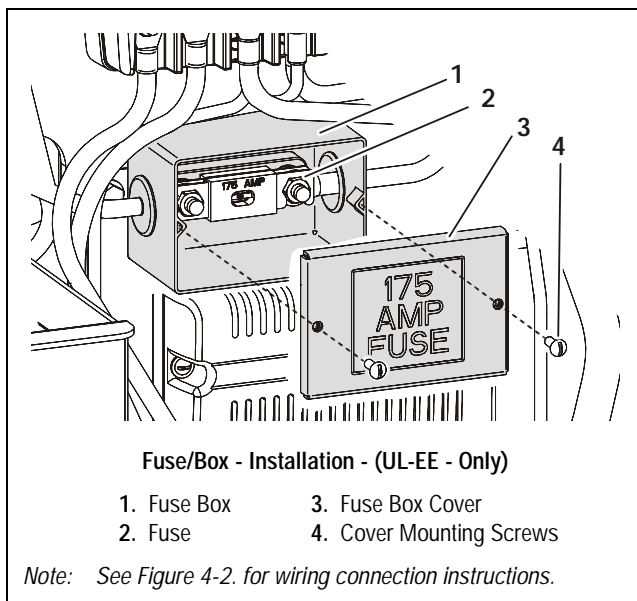

SECTION 4 - CONTROL COMPONENTS

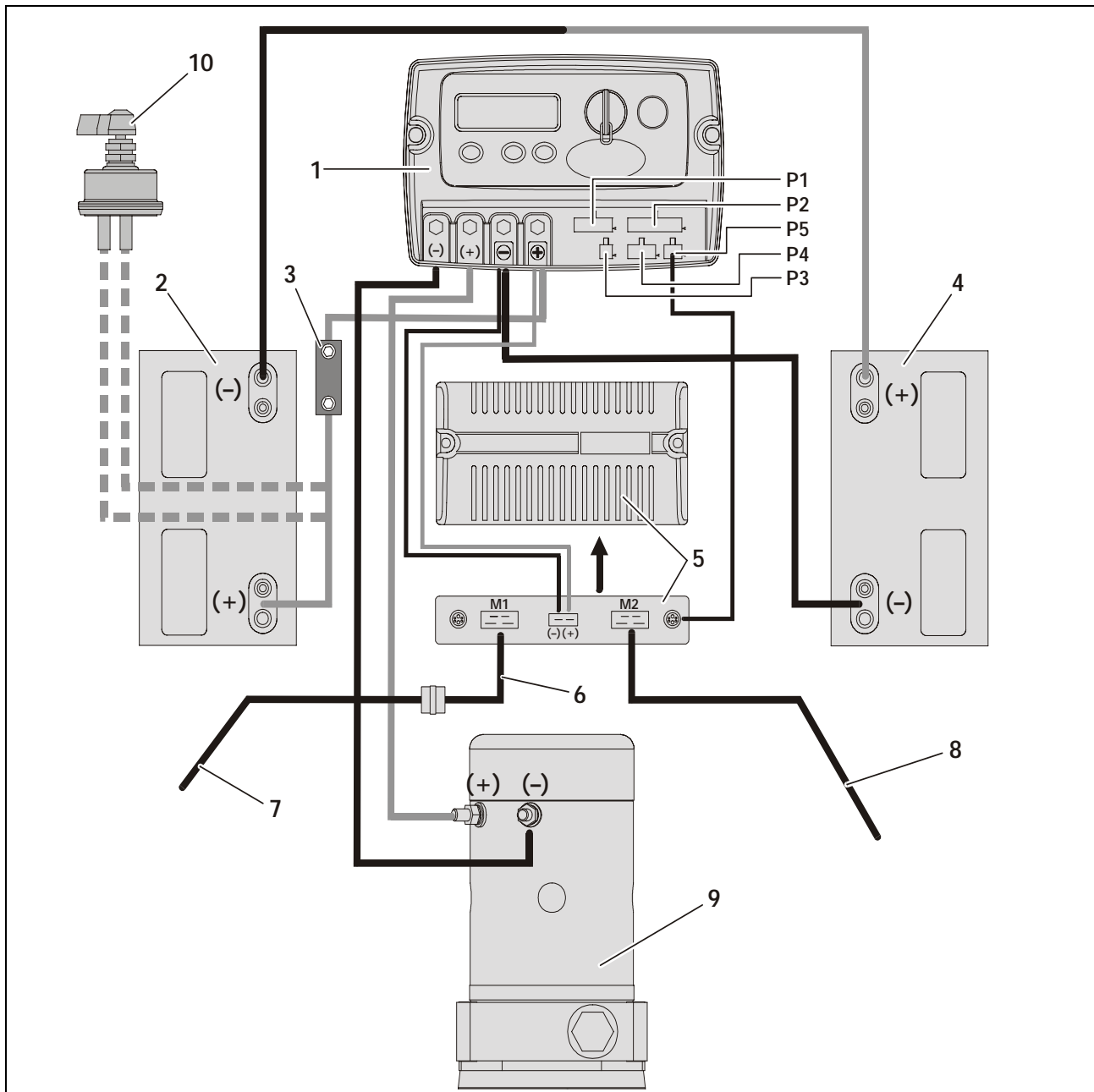

- |                              |   |                                  |
|------------------------------|---|----------------------------------|
| 1. Ground Control Module (a) | 5. Traction Control Module (a)                | 9. Pump/Motor/Tank Assembly (b)  |
| 2. Left Side Battery (b)     | 6. Left Drive Motor Harness Reverser (a)      | 10. Master Disconnect Switch (c) |
| 3. 175 Amp Fuse              | 7. Power Cable To Left Drive Motor/Brake (a)  |                                  |
| 4. Right Side Battery (b)    | 8. Power Cable To Right Drive Motor/Brake (a) |                                  |

Ground Control Module Plugs: P1 - Horn, Alarm, Beacons, Lift Down Valve Harness (a) P4 - Platform Junction Box Harness (a)  
 P2 - PHP, Elevation/Speed, Charger Limit Switch Harness (a) P5 - Joystick Protocol Harness (a)  
 P3 - Programmable Security Lock Harness (Option) (a)

Notes: (a) Apply di-electric grease JLG Part Number 3020038 to wiring harness terminals, to prevent moisture from entering module.  
 (b) Seal NEG (-) and POS (+) posts with battery grease to prevent corrosion.  
 (c) Machines equipped with the UL-EE specification (option) only.

Figure 4-2. Component Electrical Connections.



**4.4 GROUND CONTROL MODULE - SERVICE PROCEDURE**

**IMPORTANT**

DO NOT ATTEMPT TO DISASSEMBLE THE GROUND CONTROL MODULE IF MACHINE IS STILL UNDER WARRANTY. OPENING THE GROUND CONTROL MODULE WHILE THE MACHINE IS UNDER WARRANTY WILL VOID THE WARRANTY. IF UNDER WARRANTY REQUEST A REPLACEMENT MODULE FROM THE FACTORY.

The DVL Series and DVSP Ground Control Module allows for field replacement of two (2) components internal to the module.

- Emergency Stop Switch
- Power Selector Switch (Key)

**IMPORTANT**

ELECTROSTATIC DISCHARGE CAN DAMAGE COMPONENTS ON THE INTEGRATED CIRCUIT BOARD. PLACE THE GROUND CONTROL MODULE ON A NON-CONDUCTIVE SURFACE WHEN OPENING.

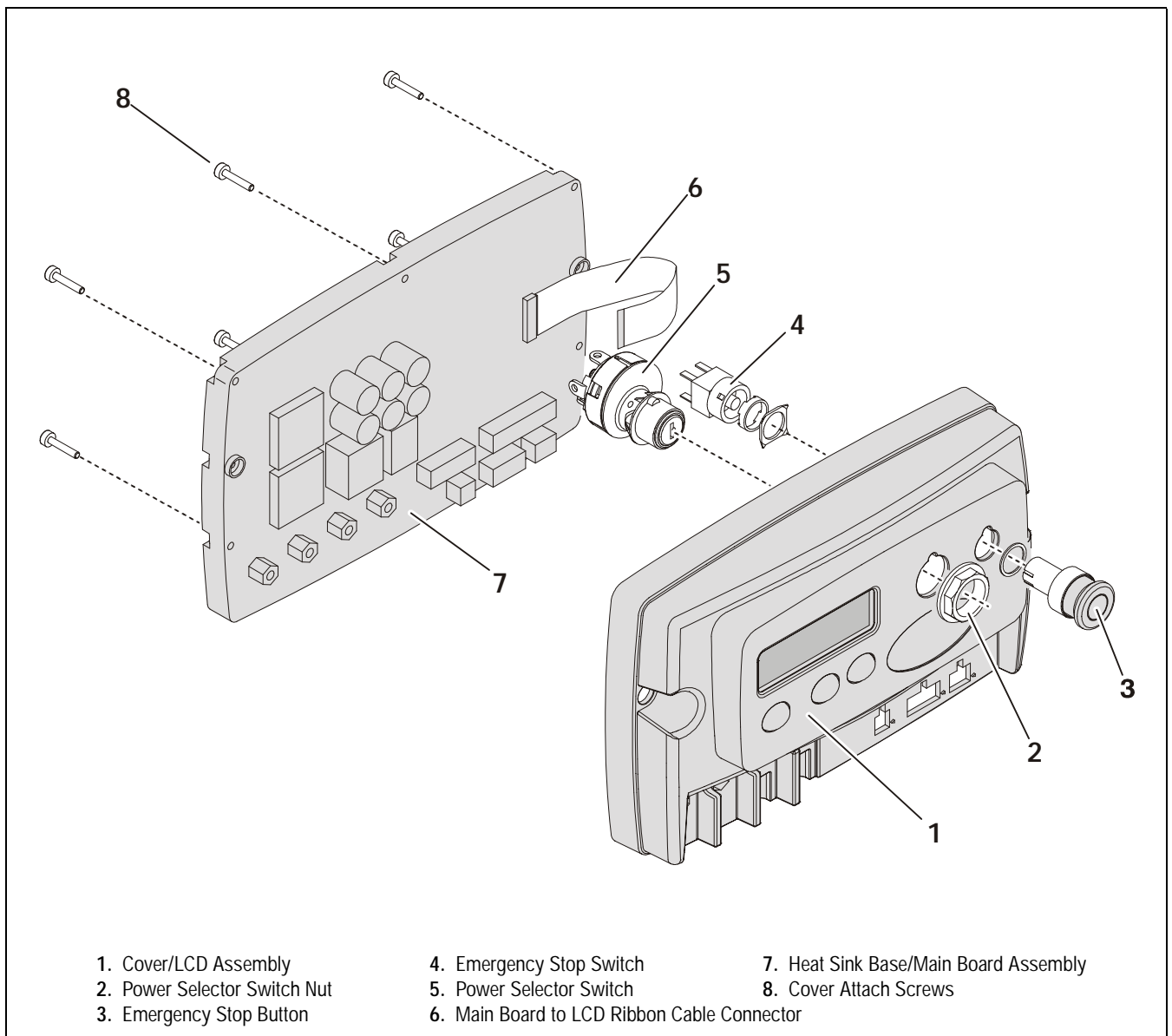

- |                              |   |                                       |
|------------------------------|---|---------------------------------------|
| 1. Cover/LCD Assembly        | 4. Emergency Stop Switch                    | 7. Heat Sink Base/Main Board Assembly |
| 2. Power Selector Switch Nut | 5. Power Selector Switch                    | 8. Cover Attach Screws                |
| 3. Emergency Stop Button     | 6. Main Board to LCD Ribbon Cable Connector |                                       |

Figure 4-3. Ground Control Module Components.

## SECTION 4 - CONTROL COMPONENTS

### Cover Removal/Installation

#### IMPORTANT

THE MAIN CIRCUIT BOARD AND THE SMALLER LCD CIRCUIT BOARD MOUNTED TO THE COVER ASSEMBLY, ARE CONNECTED BY A RIBBON CABLE. REMOVE THE COVER CAREFULLY ONCE THE COVER SCREWS ARE REMOVED FROM THE BACK OF THE MODULE.

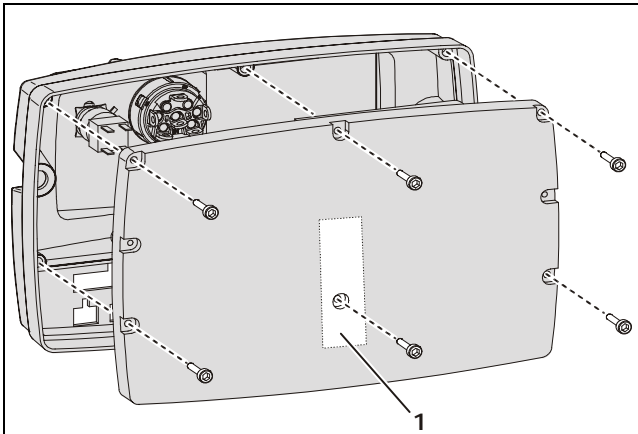

#### Cover Installation

1. Remove the (6) Hex Socket Screws from the Heat Sink/ Base. One screw is under the Warranty/Tamper Label.

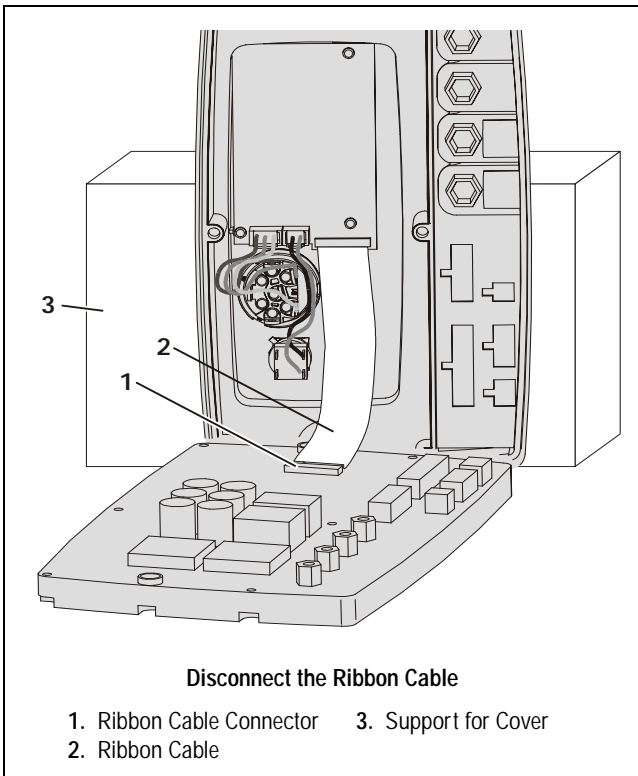

#### Disconnect the Ribbon Cable

1. Ribbon Cable Connector
2. Ribbon Cable
3. Support for Cover

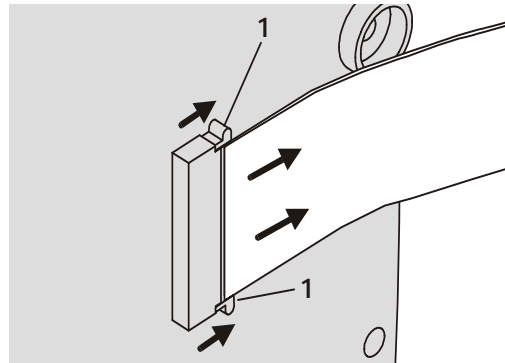

#### Release Ribbon Cable

1. Ribbon Cable Connector Tabs  
(Push tabs away from connector to release cable then slide cable out of connector)

*Note: Connector works same at both ends of the ribbon cable.*

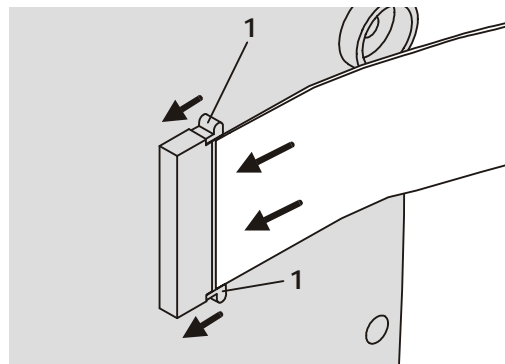

#### Reconnecting Ribbon Cable

1. Ribbon Cable Connector Release Tabs  
(Slide cable into connector then push tabs back into connector)

*Note: Connector same at both ends of the ribbon cable.*

Power Selector/EStop Switch Installation

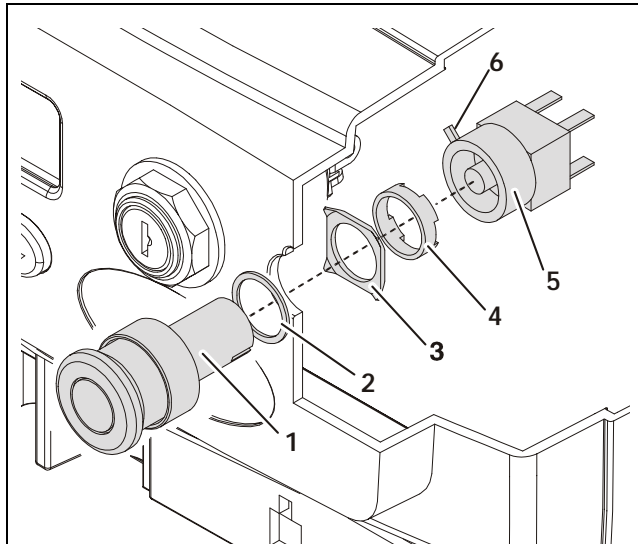

Emergency Stop Switch Installation

- 1. Emergency Stop Button
- 2. Button Seal
- 3. Square Lock Washer
- 4. Nut
- 5. Emergency Stop Switch
- 6. Switch Lock/Release Lever

*Note: Tighten nut enough to keep button from turning. Reattach wires to same terminals on new switch.*

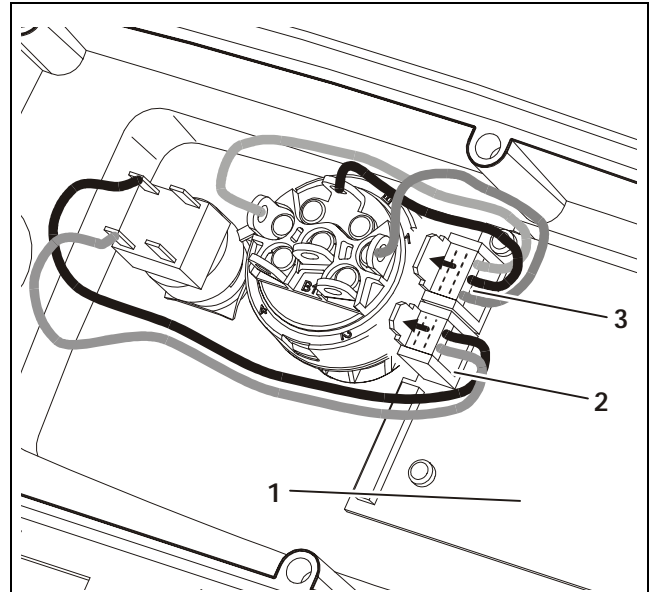

Power Selector/EStop Switch - Connectors Location

- 1. LCD and Button Circuit Board
- 2. Emergency Stop Switch Connector
- 3. Main Power Selector Switch Connector

*Note: To release switch connectors, push tab on top of connector.*

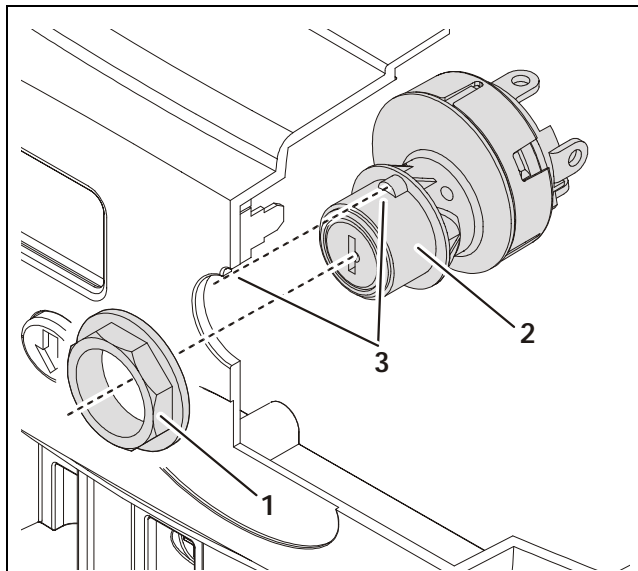

Power Selector Switch Installation

- 1. Nut
- 2. Power Selector Switch
- 3. Align and insert tab on switch into slot on cover.

*Note: Reattach wires to the same terminals on new switch.*

### 4.5 GROUND CONTROL MODULE - PROGRAMMING

#### General

The DVL/DVSP machine Ground Control Module allows on-board programming of various component and control function personality settings.

Programming may be required under circumstances such as:

- Replacement of the Ground Control or Traction Control Module some components or optional equipment may not be enabled under the standard default settings of the replacement unit.
- Optional equipment has been added to the machine in the field and that function must be enabled before operation.
- Customizing the machine to fit a specific application, such as changing the LCD display language, programming operating speeds such as braking, turning or lifting speeds.

#### Programming Levels

There are three (3) **password protected** programming levels, from highest to lowest, the levels are:

- **Level-1:** JLG Engineering Settings
- **Level-2:** Service and Maintenance Settings -  
**Level-2 Password:** 91101
- **Level-3:** Operator Settings -  
**Level-3 Password:** 33271

#### **IMPORTANT**

**THE LEVEL 1: JLG ENGINEERING SETTINGS ARE NOT DISPLAYED IN THE PROGRAMMABLE SETTINGS UNDER PASSWORD LEVEL-2 OR LEVEL-3. LEVEL-1 SETTINGS MUST NOT BE MODIFIED UNLESS DIRECTED BY JLG ENGINEERING DEPARTMENT PERSONNEL.**

**Level-1: JLG Engineering Settings** include voltage, amperage, and ohm output settings that are within the operating parameters of various machine components. This Level can adjust all programmable settings.

**Level-2: Service and Maintenance Settings** allow modification to machine personality settings such as lift speeds, drive speeds, as well as various switch polarity settings, also enable various optional equipment if installed. This level can also adjust Level-3 settings.

**Level-3: Operator Settings** allow the direct user to modify a few settings such as the language setting of text output to the Ground Control Module LCD screen, setting machine sleep time, and enabling the detection of the horn and beacon components.

#### Activating Programming Mode

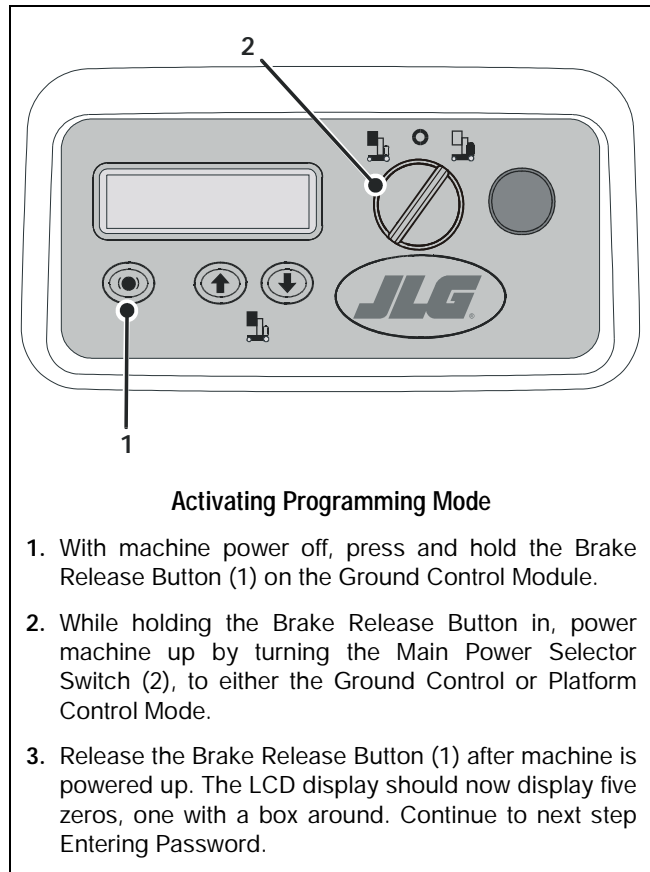

#### Activating Programming Mode

1. With machine power off, press and hold the Brake Release Button (1) on the Ground Control Module.
2. While holding the Brake Release Button in, power machine up by turning the Main Power Selector Switch (2), to either the Ground Control or Platform Control Mode.
3. Release the Brake Release Button (1) after machine is powered up. The LCD display should now display five zeros, one with a box around. Continue to next step Entering Password.

**NOTE:** If machine did not power up, check that both the Ground Control Module - Emergency Stop Button, and the Platform Control Console - Emergency Stop Button, are in the RESET position.

Also, if machine is equipped with the (PSL) Programmable Security Lock option, see Section 3.10 of your Operators Manual for additional machine power-up steps.

**Entering Password**

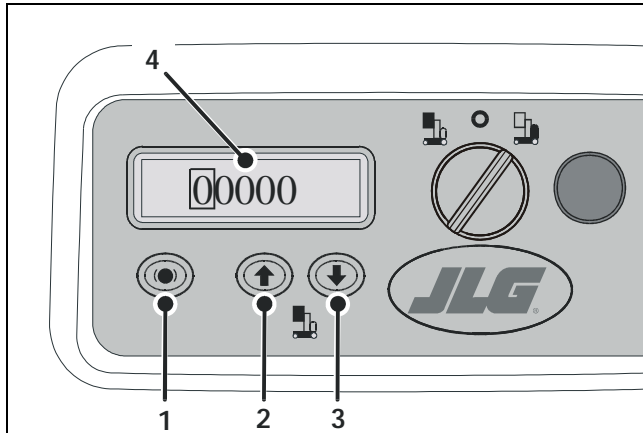

**Entering Password**

1. The Brake Release button (1) moves the box (around digit) from left to right to select which digit to change.
2. Platform UP button (2) increases the numerical digit.
3. Platform DOWN button (3) decreases the numerical digit.
4. Change all five digits (4) to match password level, then press the Brake Release button (1) again.

**Programming Mode Selection**

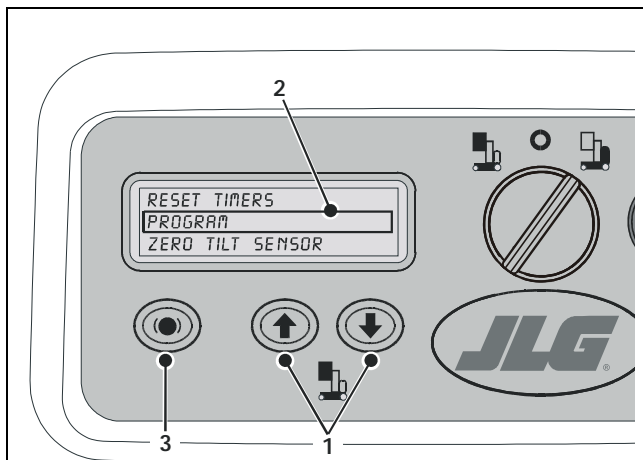

**Programming Mode Selection**

1. Use Platform UP/DOWN buttons (1) to move the selection box (2) up or down to select item to program.
2. Press the Brake Release button (3) to enter selected mode then move on to Selecting Programmable Item to Adjust.

**Selecting Programmable Item to Adjust**

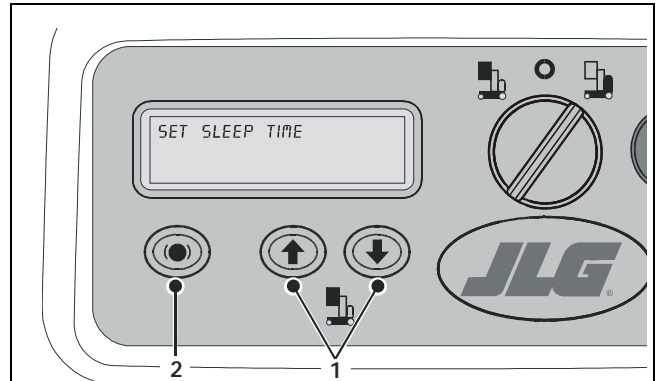

**Selecting Programmable Item to Adjust**

1. Use the Platform UP/DOWN buttons (1) to scroll through the list of programmable items available to your programming level.
2. Once a programmable item to be adjusted is selected, press the Brake Release button (2) to enter that settings' adjustment mode.

**Adjusting Programmable Setting**

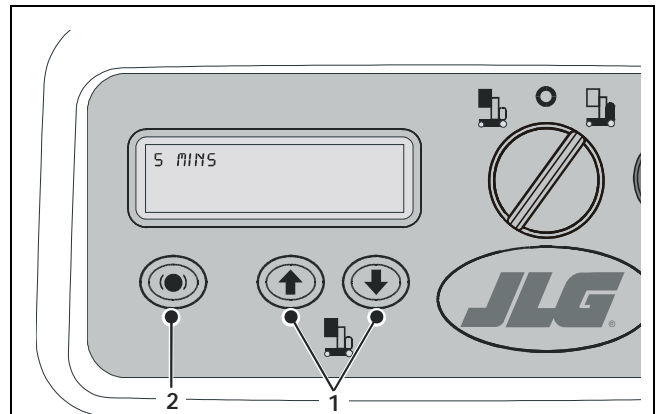

**Adjusting Programmable Setting**

1. Adjust the programmable setting using the Platform UP/DOWN buttons (1), see Table 4-1 for range of settings for the item selected.
2. Once parameter is set for the programmable item, press the Brake Release button (2), this will enter the parameter and return you to the Programmable Settings Menu.

**TO EXIT Programming Mode** after entering programmable settings, power machine off with either the Main Power Selector Switch or Emergency Stop Button.

## SECTION 4 - CONTROL COMPONENTS

### Service Programming Mode - (Level-2)

In the Service Programming Mode the following items are shown on the main menu:

- Reset Timers
- Program
- Tilt Sensor
- OSS Sensor

**NOTE:** There are two production modules available at this time, one for North/South American and European languages, and one for Asian languages. All programmable items between these modules are identical with the exception of language selection.

#### Reset Timers

This setting displays five (5) timers as described following:

- **Trip Time:** This timer shows total accumulated hours since last trip timer reset. This is the hour meter reading displayed on the Ground Control Module LCD Display during normal machine operation.
- **Traction Time:** Displays the amount of accumulated DRIVE hours on the machine's current drive components.
- **Lift UP Time:** Displays the amount of accumulated time the machine has operated the Lift UP function.
- **Lift DOWN Time:** Displays the amount of accumulated time machine has operated the Lift DOWN function.
- **Total Time:** Displays the total amount of time accumulated by the Traction, Lift UP and Lift DOWN Timers.

Of these five (5) timers, only the Trip Timer can be RESET back to zero (00000.0).

#### Program

Allows service personnel to program the Level-2 and Level-3 items shown in Table 4-1.

#### Tilt Sensor

Allows service personnel to reset the Ground Control Module's internal digital Tilt Sensor to zero (0.0) degrees in both the X and Y axis.

### **⚠ DANGER**

ZEROING THE TILT SENSOR REQUIRES THE MACHINE TO BE RESTING ON A SURFACE CHECKED WITH A DIGITAL LEVEL MEASURING WITHIN 0.0 DEGREES LEVEL IN BOTH THE X AND Y AXIS DIRECTIONS.

**NOTE:** When entering this mode the LCD will display in real time the current X and Y degree readings of the tilt sensor. The reading being displayed is based on the previous zero setting and may not reflect level of the machines current resting surface.

1. Position the machine on a level surface verified level in both the X and Y axis with a digital level.
2. Select "Zero Tilt Sensor" from the menu and press the Brake Release button.
3. The current tilt sensor readings are displayed. To zero both the X and Y direction sensor setting to the machines' present resting surface, press the Brake Release button.
4. Select "Back to Main Menu" and press the Brake Release Button.
5. Power machine off and begin operation.

#### OSS Sensor

Displays current Obstruction Sensor System status (Detection - YES/NO). Also if an object is detected, the sensor(s) detecting the object and distance the object is from the sensor is displayed.

1	DETECTION	---	---	NO		
2	1	∅in	0	4	∅in	0
	2	∅in	0	5	∅in	0
3	3	∅in	0	6	∅in	0

**OSS Sensor LCD Display Mode**

1. Detection Indicator - Yes/No
2. Sensor numbers
3. Object distance from sensor
4. Signal strength

*Note: This screen can be viewed while another person performs the transducer sensor check, see Section 4.9.*

### Operator Programming Mode - (Level-3)

In the Operator Programming Mode the following items are shown on the main menu (Also See Table 4-1):

- Tilt Sensor
- Program

**NOTE:** There are two production modules available at this time, one for North/South American and European languages, and one for Asian languages. All programmable items between these modules are identical with the exception of language selection.

#### Tilt Sensor

Allows viewing current tilt sensor individual X and Y direction degree reading.

#### Program

Allows the Operator to program Level-3 items shown in Table 4-1.

Table 4-1. DVL/DVSP Ground Control Module - Field Programmable Settings and Factory Preset.

Level-2: Service Level Settings		On LCD Display: YES = ✓ HIGH = ↑	
Level-3: Operator Level Settings		NO = ✕ LOW = ↓	
LEVEL	PROGRAMMABLE ITEM	FACTORY PRESET	SETTING RANGE
2	Back to Main	-	Return to Programming Menu
3	Set Language  <i>NOTE: There are two production modules available at this time, one for North/South American and European Languages, and one for Asian Languages.</i>	1	1 - English 6 - Italian 2 - German 7 - Swedish 3 - Dutch 8 - Brazilian Portuguese 4 - French 9 - Finnish 5 - Spanish
		2	1 - English 3 - Japanese 2 - Chinese
2	Set Maximum Lift Up Speed	100%	0 - 100%
2	Set Maximum Lift Down Speed	100%	0 - 100%
2	Zero the On-Board Tilt Sensor	NO	YES/NO
2,3	Set Sleep Time	5 MINS	0 - 60 MINS
2	Set Polarity Of Left Pot Hole Input 1	2	0 - Disabled / 1 - LOW / 2 - HIGH
2	Set Polarity Of Right Pot Hole Input 2	2	0 - Disabled / 1 - LOW / 2 - HIGH
2	Set Polarity Of Up Limit/elevation Input	HIGH	HIGH/LOW
2	Set Polarity Of Charger Inhibit	HIGH	HIGH/LOW
2,3	Set Polarity Of The Keypad Code	LOW	HIGH/LOW
2	Set Polarity Of Ancillary Input 1	LOW (a)	HIGH/LOW
2	Set Polarity Of Ancillary Input 2	LOW (b)	HIGH/LOW
2,3	Enable Detection Of Horn Open Circuit	NO (c)	YES/NO
2,3	Enable Detection Of Beacon Open Circuit	NO (c)	YES/NO
2	Enable Obstruction Sensor System (OSS)	NO	YES/NO
2	Enable Detection Of Aux. #1 Open Circuit	NO (d)	YES/NO
2	Enable Detection Of Aux #2 Open Circuit	NO (d)	YES/NO
2	Acceleration (Platform Lowered)	40	1 - 100
2	Deceleration (Platform Lowered)	45	1 - 100
2	Turn Acceleration (Platform Lowered)	30	1 - 100
2	Turn Deceleration (Platform Lowered)	30	1 - 100
2	Maximum Forward Speed (Platform Lowered)	100	1 - 100
2	Minimum Forward Speed (Platform Lowered)	30	1 - 100
2	Maximum Reverse Speed (Platform Lowered)	100	1 - 100
2	Minimum Reverse Speed (Platform Lowered)	20	1 - 100
2	Maximum Turn Speed (Platform Lowered)	30	1 - 100
2	Minimum Turn Speed (Platform Lowered)	10	1 - 100
2	Minimum Forward Speed (Platform Elevated)	20	1 - 100
2	Minimum Reverse Speed (Platform Elevated)	20	1 - 100
2	Maximum Turn Speed (Platform Elevated)	5	1 - 100
2	Motor Compensation	90 mOhms	0 - 500 mOhms
3	Forward Alarm Disable	NO	YES/NO
3	OSS Diagnostic	NO	YES/NO
2	Mode Select Delay (Drive/Lift Mode active before timeout)	5 Sec.	0 - 60 Seconds
2	Invert Lift Direction	X	YES/NO
2	Lift Lock Delay	5 Sec.	0 - 60 Seconds

**Notes:** (a) DVSP Models equipped with stock-picker platform and mid-gate interlock (drive inhibit) switch are factory preset to HIGH.  
 (b) DVSP Models equipped with 12 ft. lift-limit-switch option are factory preset to HIGH.  
 (c) DVSP Models this feature is standard equipment and are factory preset to YES.  
 (d) This circuit is currently unused on both DVL/DVSP Models.

## 4.6 PLATFORM CONTROL CONSOLE - SERVICE PROCEDURES (MACHINES S/N - 0130007616 TO PRESENT)

### General

#### **IMPORTANT**

DO NOT ATTEMPT TO DISASSEMBLE THE PLATFORM CONTROL BOX IF MACHINE IS STILL UNDER WARRANTY. OPENING THE PLATFORM CONTROL BOX WHILE THE MACHINE IS UNDER WARRANTY WILL VOID THE WARRANTY. IF UNDER WARRANTY REQUEST A REPLACEMENT BOX FROM THE FACTORY.

The platform control console allows for replacement of nine (9) components.

- Emergency Stop Switch
- Key Switch
- Joystick Assembly
- Display/Controller Module
- Drive/Lift Mode Selector Switch
- Horn Button Switch
- Rear Cover
- Wiring Harness Connector Socket
- Mounting Bracket

### Remove Platform Control Console

First remove the platform control console completely from the platform assembly, See Section 4.3, Control Components - Installation, Platform Control Console Installation.

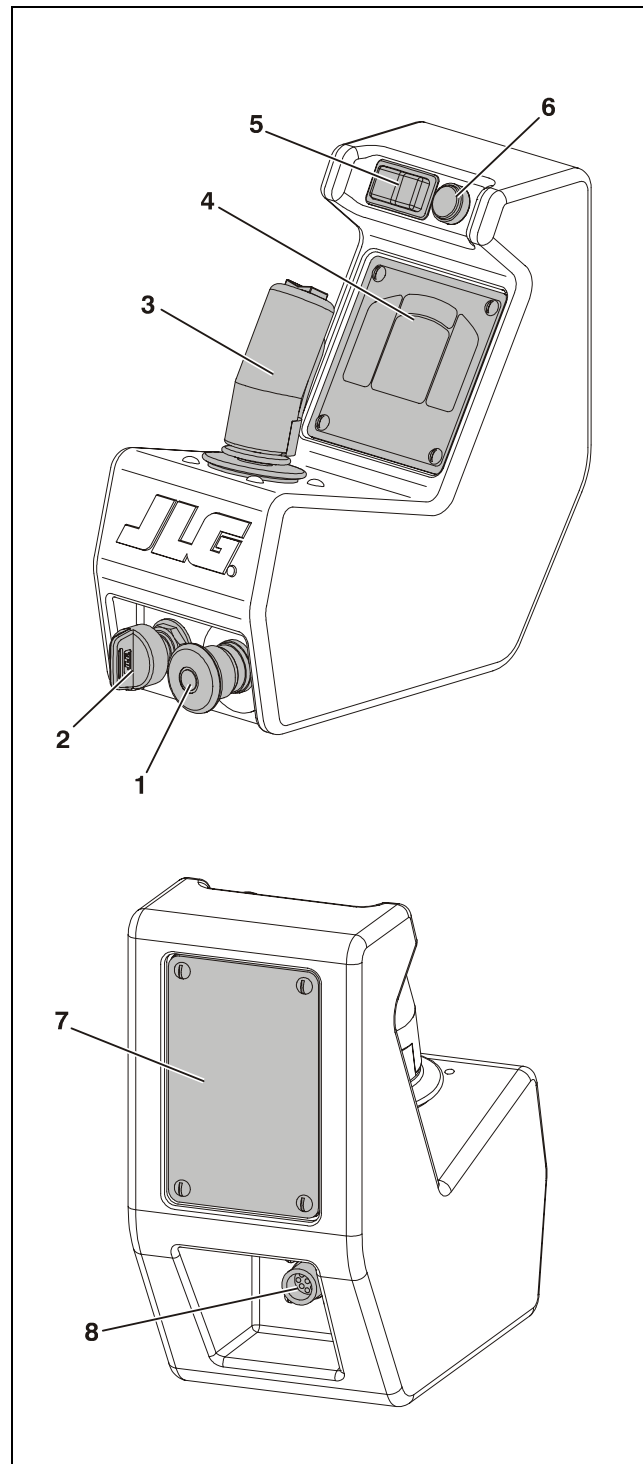

Figure 4-4. Platform Control Console Components.

- |                              |                                    |
|------------------------------|------------------------------------|
| 1. E-Stop/Shutdown Switch    | 5. Drive/Lift Mode Selector Switch |
| 2. ON/OFF Key Switch         | 6. Horn Button Switch              |
| 3. Joystick Assembly         | 7. Rear Cover                      |
| 4. Display/Controller Module | 8. Wiring Harness Connector        |



### Display/Controller Module Electrical Connections

The internal switches and joystick controller of the platform console, plug directly into the Display/Controller Module. This module then relays the signals from these switches to the Ground Control Box through the communications cable running to the platform junction box mounted to the mast under the platform.

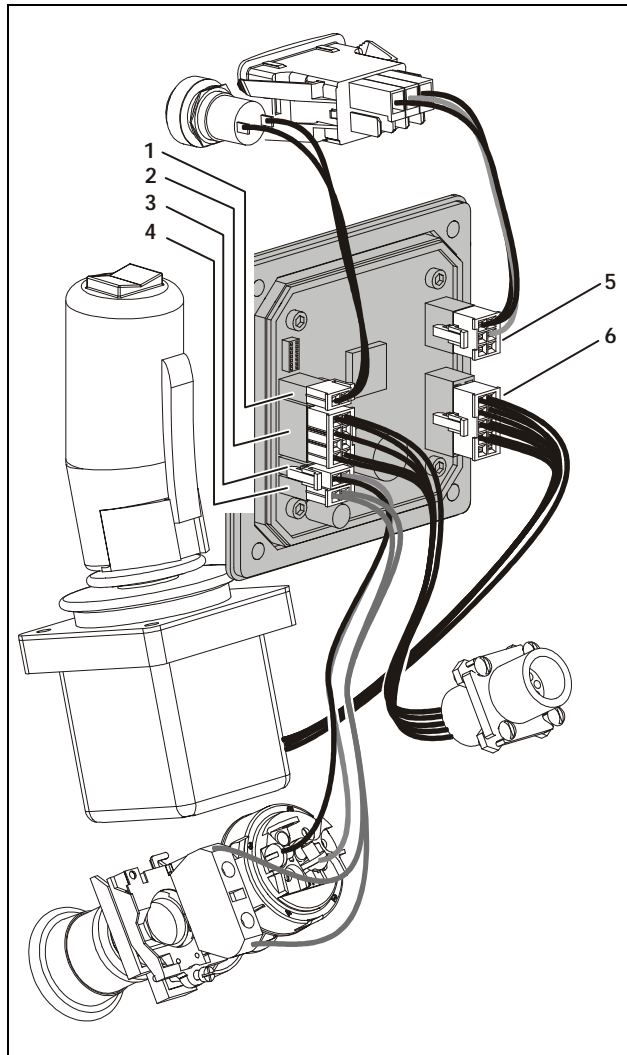

Platform Console - Circuit Board Connections

- |   |  |
|---|--|
| 1. Horn Switch - (C5)                                   | 4. E-Stop/ShutDown Switch - (C4)       |
| 2. Communications Cable to Platform Junction Box - (C6) | 5. Drive/Lift ModeSelect Switch - (C7) |
| 3. ON/OFF Key Switch (C3)                               | 6. Joystick - (C8)                     |

**Note:** The (C) numbers shown after the description above represent the corresponding identification of the plug on the module's circuit board.

### Mounting Bracket - Install/Remove

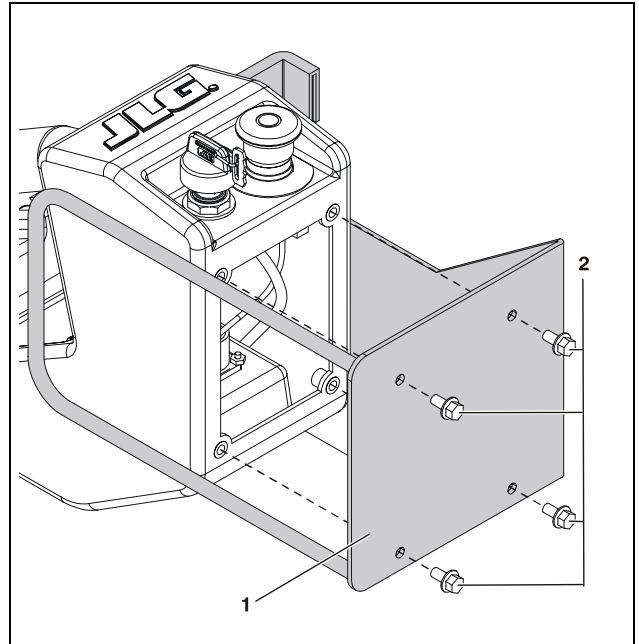

Platform Console - Mounting Bracket

- |                     |                       |
|---------------------|-----------------------|
| 1. Mounting Bracket | 2. Bracket Screws (a) |
|---------------------|-----------------------|

**Note:** (a) Apply Loctite #242 to screw threads on final assembly.

### Rear Cover - Install/Remove

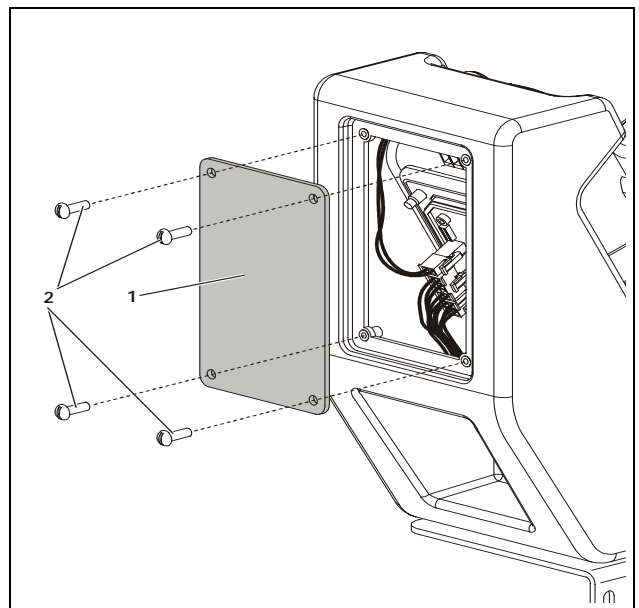

Platform Console - Rear Cover Installation

- |               |                          |
|---------------|--------------------------|
| 1. Rear Cover | 2. Cover Mounting Screws |
|---------------|--------------------------|

Display/Controller Module - Install/Remove

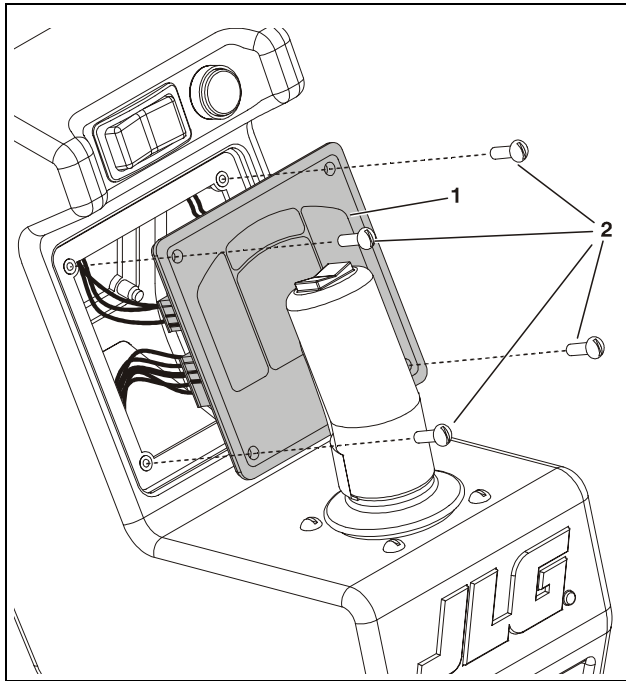

Platform Console - Display Module

- 1. Display/Controller Module (a)
- 2. Mounting Screws

**Note:** (a) Unplug all connections on the back of the module before removing from console.

Horn Button Switch - Install/Remove

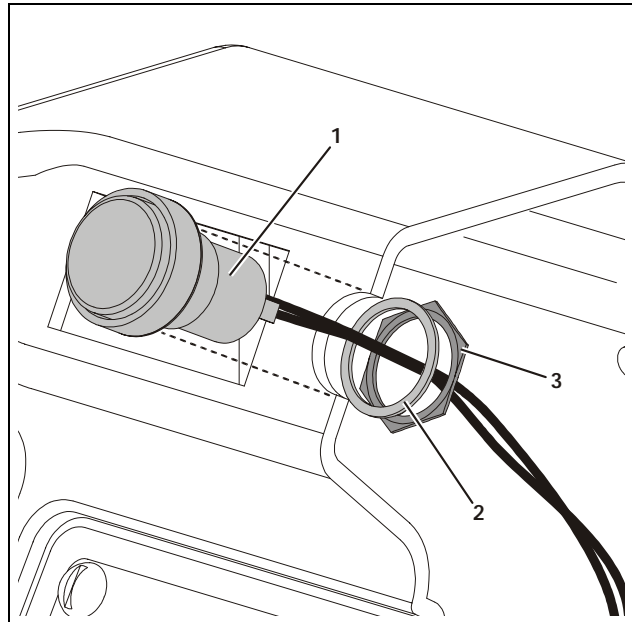

Platform Console - Horn Switch Installation

- 1. Horn Button Switch (a)
- 2. Lock Washer
- 3. Nut

**Note:** (a) Remove rear cover, unplug wire, remove nut and lock washer then slide switch out of console.

Drive/Lift Mode Switch - Install/Remove

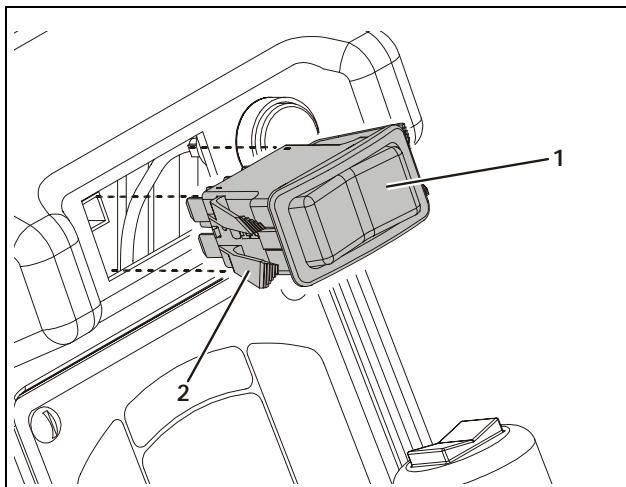

Platform Console - Drive/Lift Mode Select Switch

- 1. Switch Assembly (a)
- 2. Locking Tabs

**Note:** (a) Remove rear cover, unplug switch wire, press tabs to remove.

Key Switch - Install/Remove

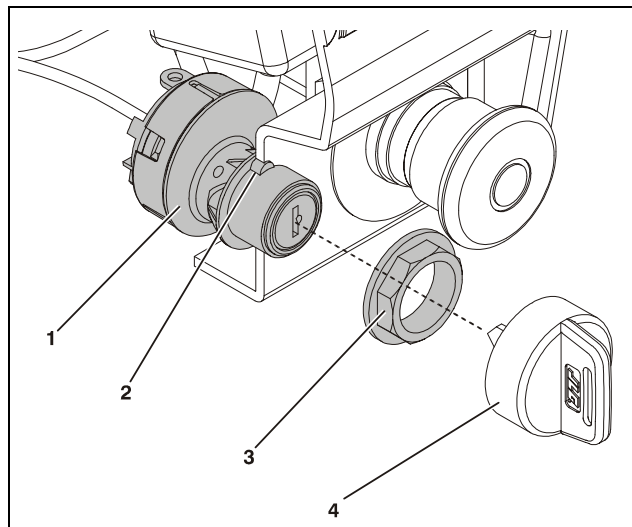

Platform Console - Key Switch Installation

- 1. Key Switch (a)
- 2. Notch
- 3. Attach Nut
- 4. Key

**Note:** (a) Remove mounting bracket on bottom of console to gain access to the key switch assembly.

E-Stop/ShutDown Switch - Install/Remove

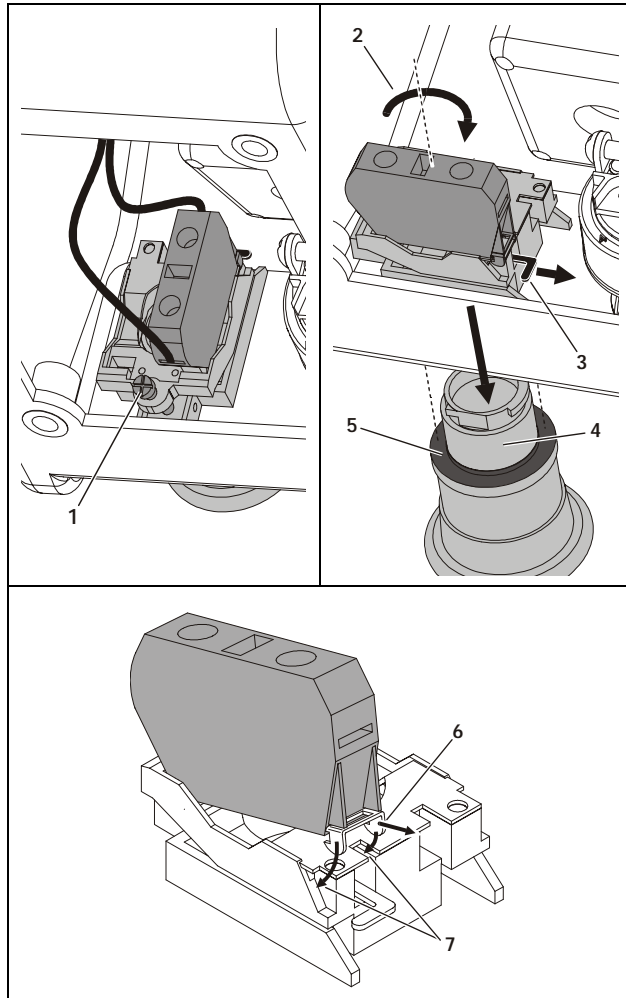

Platform Console - E-Stop Switch Installation

- |   |                                      |
|---|--------------------------------------|
| 1. Loosen Switch Set Screw              | 5. Barrel Seal                       |
| 2. Turn Switch 90°                      | 6. Switch to Body Retainer Hooks (a) |
| 3. Pull Spring-Loaded Release Lever Out | 7. Switch Retainer Slots             |
| 4. Remove Barrel Assembly               |                                      |

**Note:** (a) Use a small straight blade screwdriver to extend the spring-loaded retainer hooks (6) out and release the switch from the body.

Joystick Assembly - Install/Remove

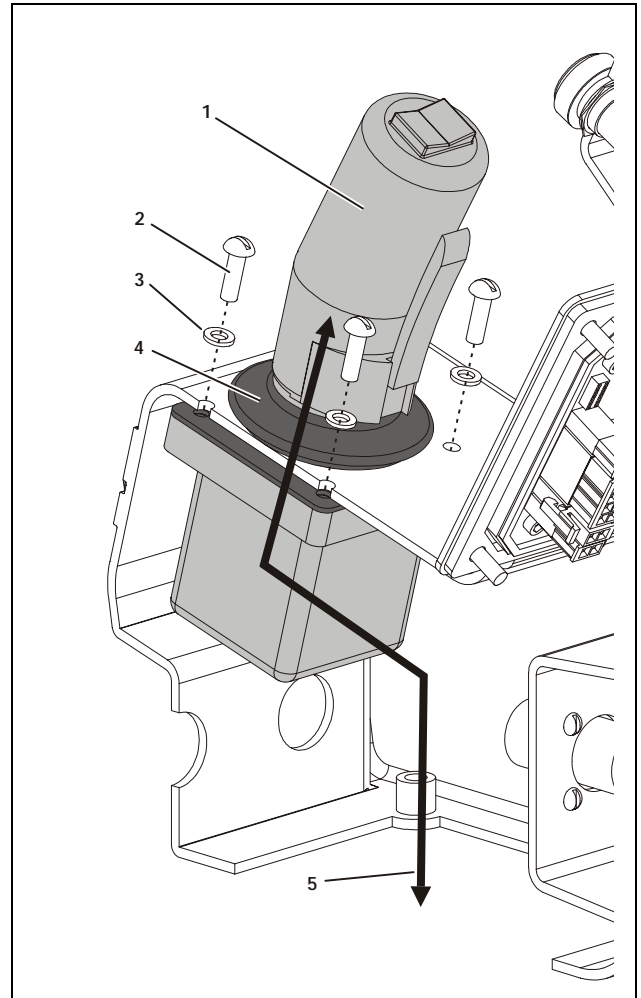

Platform Console - Joystick Installation

- |                           |   |
|---------------------------|---|
| 1. Joystick Assembly      | 4. Rubber Boot/Gasket   |
| 2. Attach Screws (Qty.-4) | 5. Install/Remove through the Access Hole in Bottom of Housing. (a) (b) |
| 3. Nylon Washers (Qty.-4) |   |

**Note:** (a) Remove the console mounting bracket.  
 (b) Remove the key switch and e-stop switch to remove joystick assembly through access hole in bottom of console.

**4.7 PLATFORM CONTROL CONSOLE - SERVICE PROCEDURES (MACHINES PRIOR TO S/N - 0130007616)**

**General**

**IMPORTANT**

DO NOT ATTEMPT TO DISASSEMBLE THE PLATFORM CONTROL BOX IF MACHINE IS STILL UNDER WARRANTY. OPENING THE PLATFORM CONTROL BOX WHILE THE MACHINE IS UNDER WARRANTY WILL VOID THE WARRANTY. IF UNDER WARRANTY REQUEST A REPLACEMENT BOX FROM THE FACTORY.

The DVL Series and DVSP platform control console allows for replacement of four (4) components internal to the box.

- Joystick Assembly
- Emergency Stop Switch
- Upper/Lower Shell Gasket
- Button Pad Switch

ELECTROSTATIC DISCHARGE CAN DAMAGE COMPONENTS ON THE INTEGRATED CIRCUIT BOARD. BE CERTAIN TO DISSIPATE ANY ELECTROSTATIC ENERGY FROM YOURSELF BEFORE DIRECTLY TOUCHING THE CIRCUIT BOARD INSIDE THE CONTROL UNIT. PLACE THE PLATFORM CONTROL BOX ON A NON-CONDUCTIVE SURFACE WHEN OPENING THE BOX AND WORKING DIRECTLY WITH THE CIRCUIT BOARD.

**Remove Platform Control Console**

First remove the platform control console completely from the platform assembly, See Section 4.3, Control Components - Installation, Platform Control Console Installation.

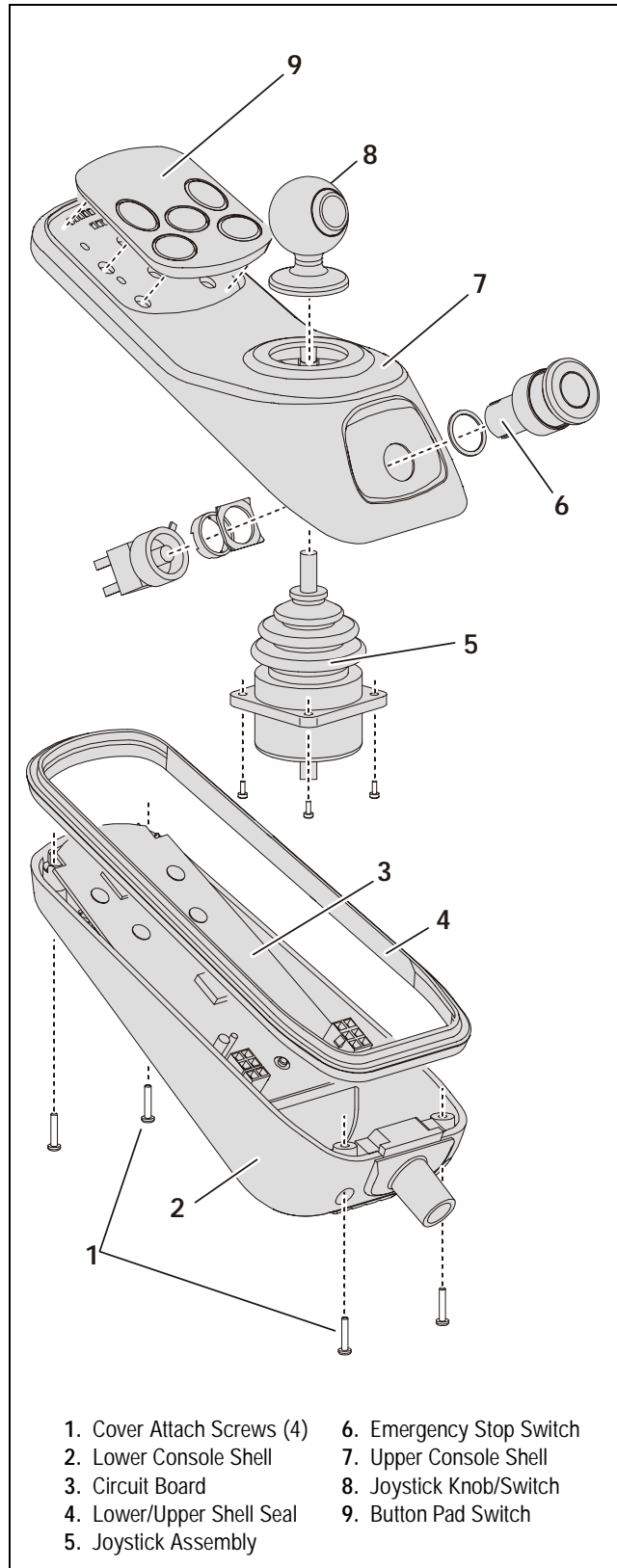

- |                            |                          |
|----------------------------|--------------------------|
| 1. Cover Attach Screws (4) | 6. Emergency Stop Switch |
| 2. Lower Console Shell     | 7. Upper Console Shell   |
| 3. Circuit Board           | 8. Joystick Knob/Switch  |
| 4. Lower/Upper Shell Seal  | 9. Button Pad Switch     |
| 5. Joystick Assembly       |                          |

Figure 4-5. Platform Control Console Components.

Upper/Lower Shell Attach Screws

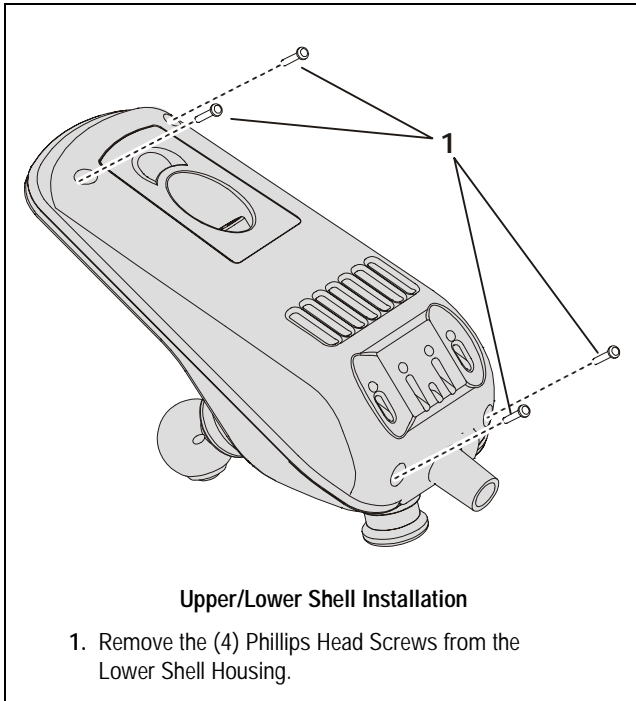

**IMPORTANT**

CAREFULLY SLIDE THE UPPER SHELL HALF FROM THE LOWER SHELL HALF. THE COMPONENTS MOUNTED IN THE UPPER SHELL HALF CONNECT TO THE CIRCUIT BOARD IN THE LOWER SHELL HALF.

Upper/Lower Shell Component Connections

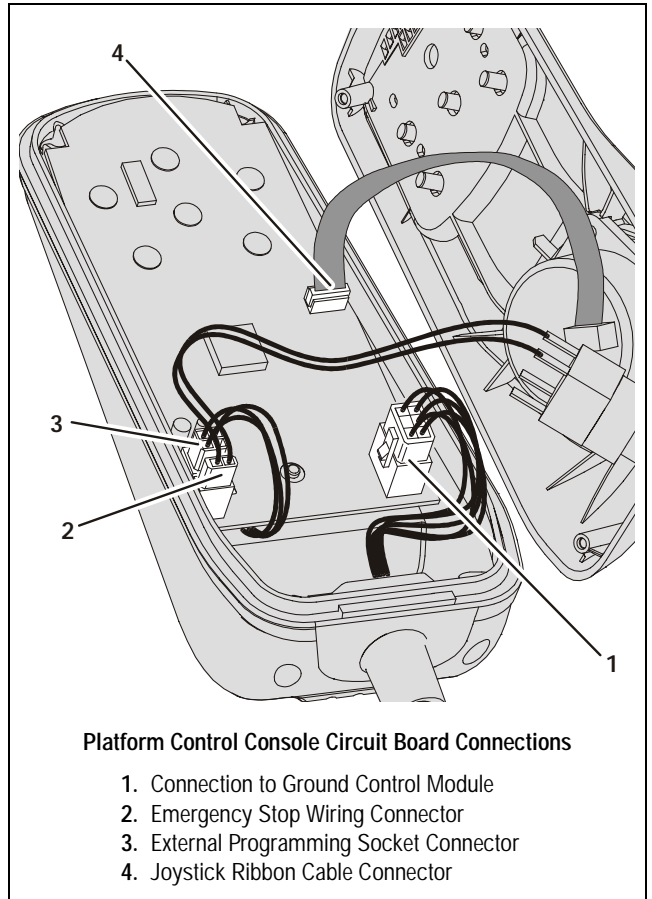

Emergency Stop Switch Installation

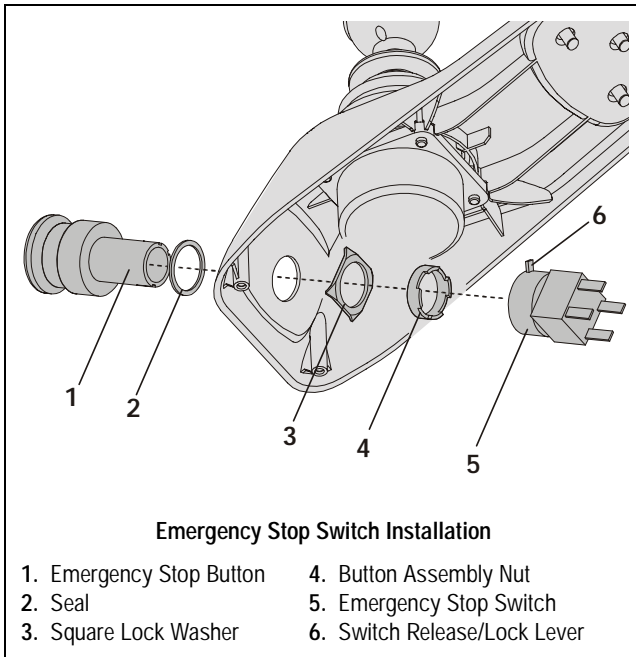

Button Pad Installation

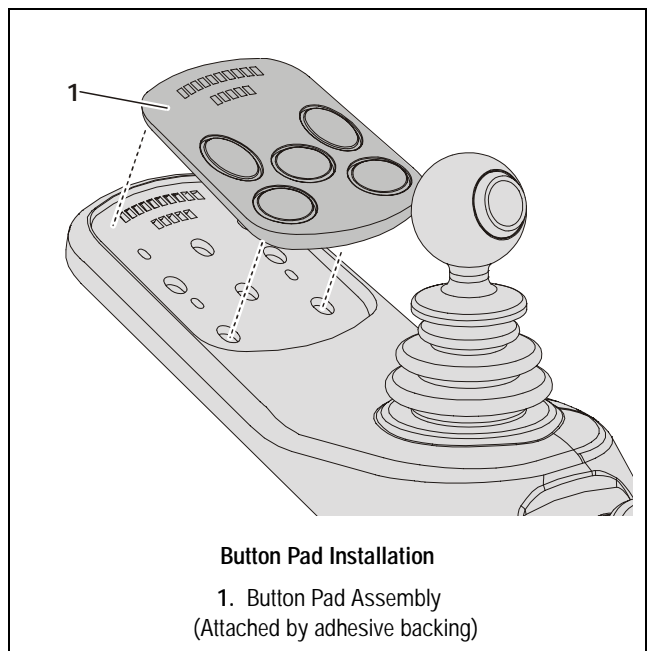

**Joystick Assembly Installation**

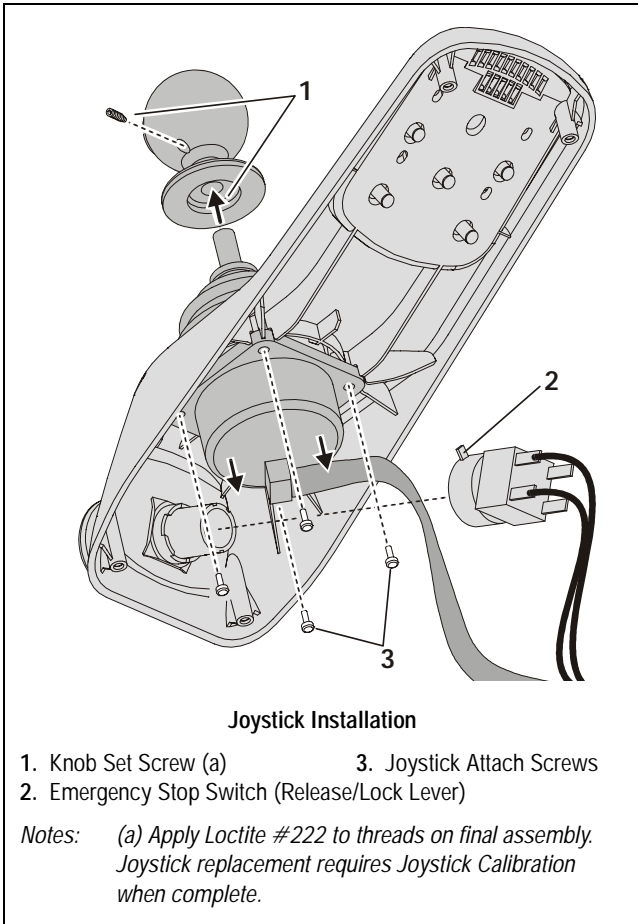

**Joystick Calibration Procedure**

1. Turn off all power to the platform control module.
2. Plug jumper tool JLG Part Number 7024361 into the programming socket under the front of the platform control console. This will short pins two (2) and three (3) in the socket.

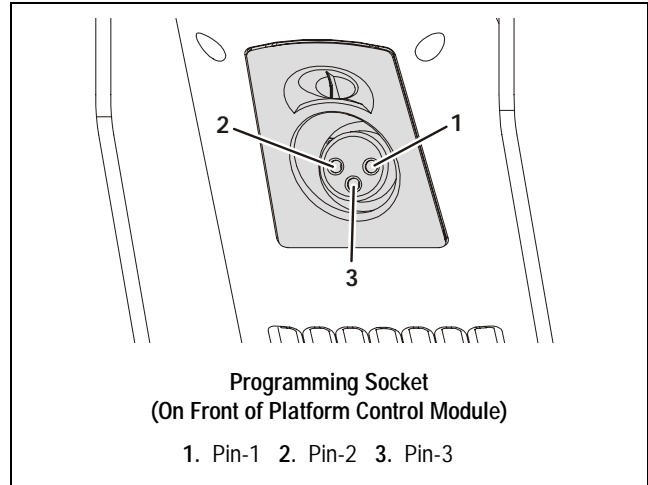

3. Turn the machine power on while holding down the turtle button on the platform control module button pad.
4. The platform control LED's will indicate calibration mode selected - 10 (ALL) LED's flashing.
5. Release the turtle button.
6. Run the joystick shaft around the gate of the of the joystick two (2) to three (3) times. Release the joystick to center.

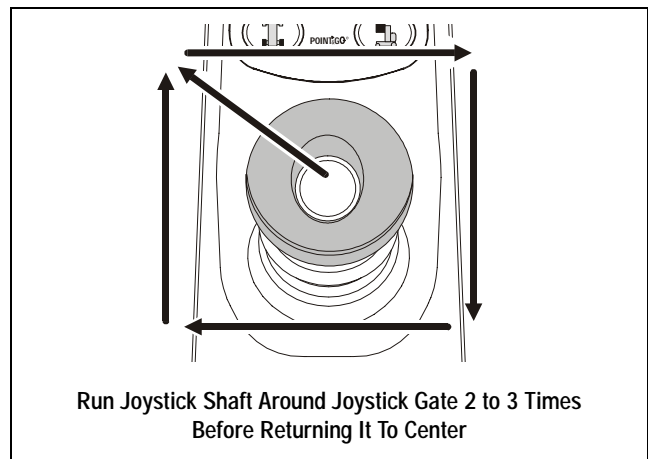

7. Disconnect the jumper tool from the socket under the front of the platform control module.
8. Turn off system power.

The joystick calibration is now complete.

**4.8 PUMP-MOTOR ASSEMBLY - SERVICE PROCEDURE**

**General**

The following is a complete disassembly/assembly of the DVL/DVSP machines' pump/motor assembly. No internal parts to the hydraulic pump are serviced by JLG except for a pump installation seal kit. Also the only parts serviceable internal to the pump electric motor is the motor brush kit.

**NOTE:** During reassembly of the pump/motor assembly, apply a liberal coat of JLG recommended hydraulic fluid to all seals and o-rings. Also keep all internal metal parts clean and coated with hydraulic fluid to prevent surface corrosion. JLG recommends replacing all seals and o-rings when disassembling and reassembling the pump/motor unit.

The motor and motor brushes can be serviced without removing the complete pump/motor unit. However components on the bottom end of the unit will require removal of the complete pump/motor unit. See Pump/Motor/Tank Installation instructions following.

**Inline Hydraulic Filter Installation**

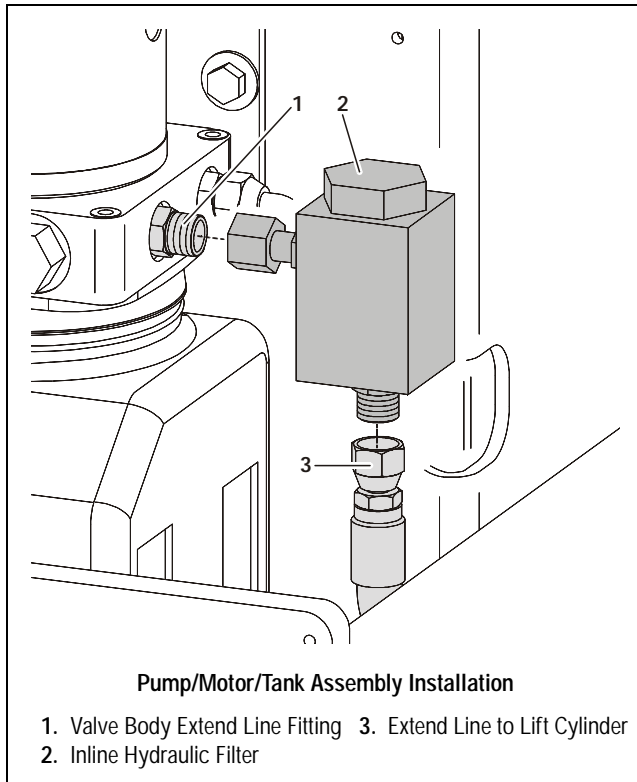

**Pump/Motor/Tank Installation**

**IMPORTANT**

BE CERTAIN THE MAST IS FULLY LOWERED BEFORE REMOVING ANY HYDRAULIC LINES FROM THE PUMP UNIT. WEAR PROTECTIVE GEAR WHEN WORKING AROUND PRESSURIZED HYDRAULIC LINES. REMOVE CONNECTIONS CAREFULLY AND CAP ALL LINES.

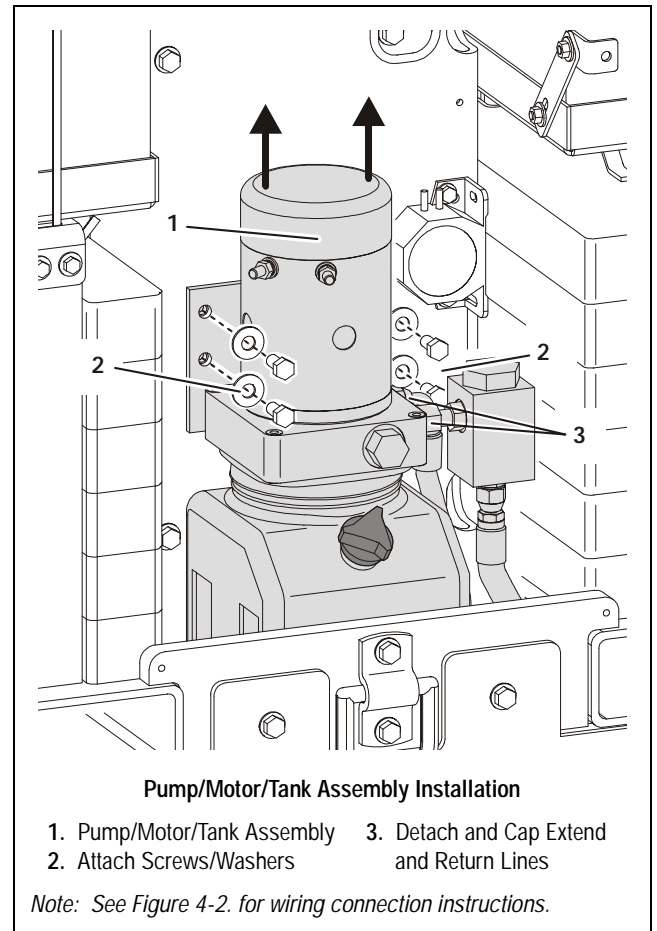

## SECTION 4 - CONTROL COMPONENTS

### Motor Cap/Motor Installation

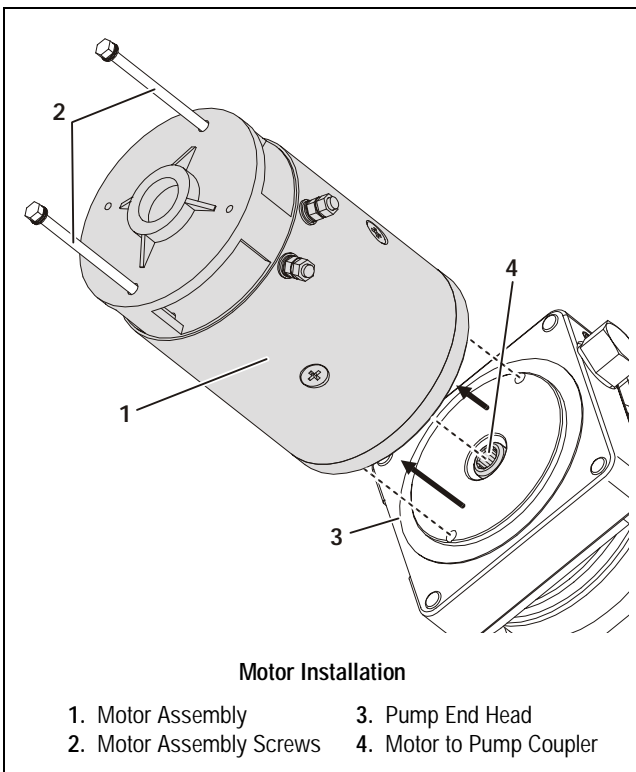
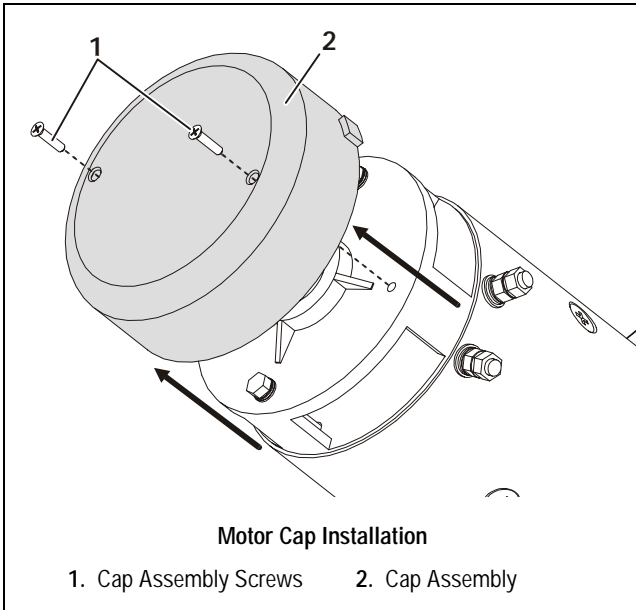

### Motor Brush Installation

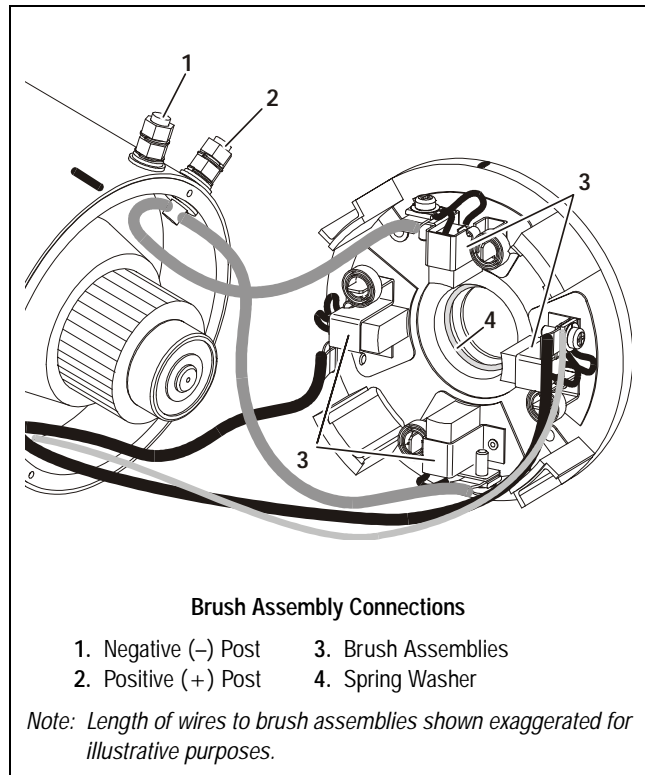
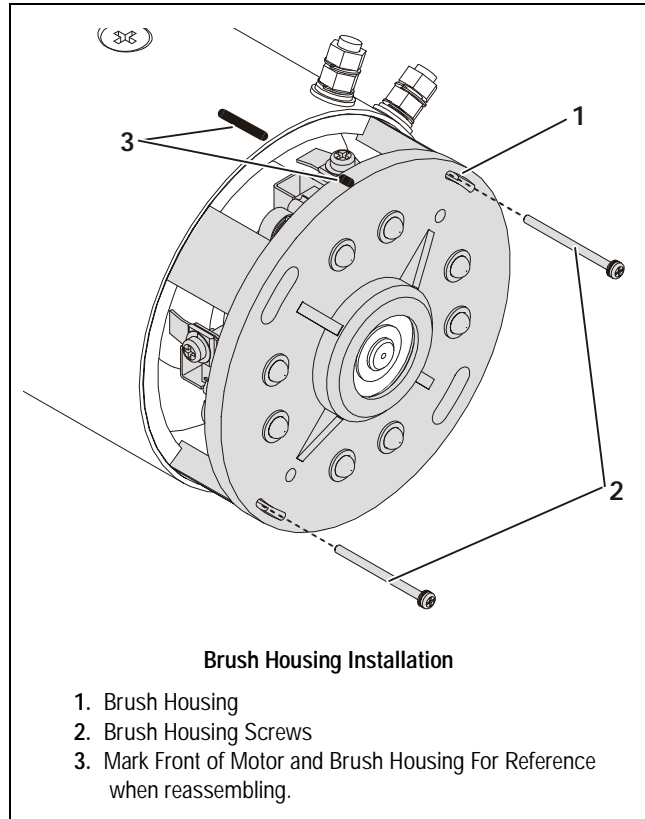



Once brush housing has been removed, inspect the rotor commutator for excessive wear before installing a new brush set.

The rotor commutator surface when new, is approximately 1/8 in. (3mm) in thickness.

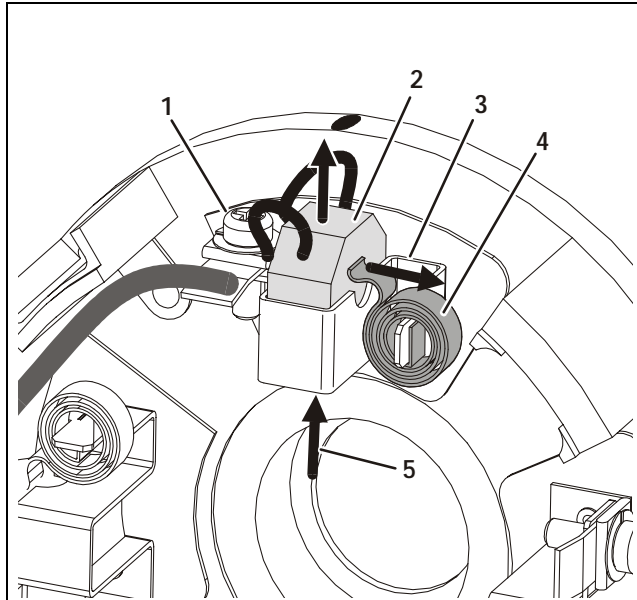

**New Brush Installation**

- 1. Brush Terminal Screw
- 2. Brush
- 3. Brush Holder
- 4. Brush Spring
- 5. (See Installation Note Below)

Installation the same for all four (4) brush assemblies.

*Note: Using a clean towel, push each brush (2) up into it's holder (3), slide the spring (4) over the side of the brush. This will hold each brush in place and allow them to clear the rotor commutator during reassembly.*

*Clean the rotor commutator with a non-conductive electrical cleaner before assembling the brush housing to the motor housing.*

### Brush Housing Final Assembly Tips

It is easier to install the brush housing assembly by sliding the rotor assembly completely out of the other end of the motor housing, then attach the brush housing first. After the brush housing is installed look into the motor housing from the opposite end to check that the positive (+) post wires and static winding wires are positioned not to block the holes for the motor mounting bolts, and are properly positioned around the motor housing.

After final assembly of the brush housing check that all brush terminal screws are tight and the brush springs are positioned properly before mounting the motor to the pump/motor end head.

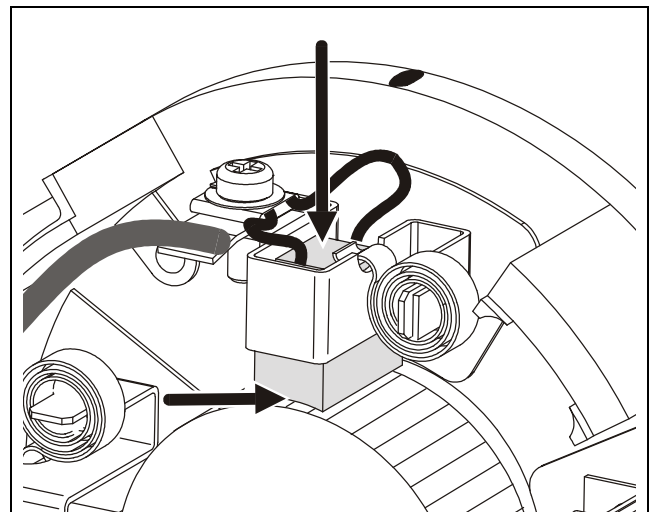

**Brush Final Positioning**

#### **IMPORTANT**

**ONCE THE ROTOR ASSEMBLY IS IN PLACE, REMEMBER TO PUSH EACH BRUSH DOWN UNTIL THE BRUSH FACE IS IN CONTACT WITH THE COMMUTATOR ON THE ROTOR SHAFT AND THE BRUSH SPRING IS PUSHING DOWN ON TOP OF THE BRUSH.**

## SECTION 4 - CONTROL COMPONENTS

### Tank Installation

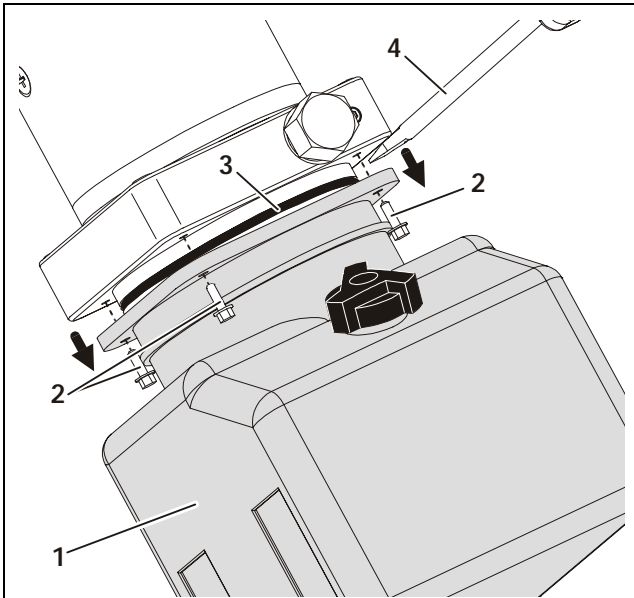

**Tank Installation**

- |                    |   |
|--------------------|---|
| 1. Tank Assembly   | 3. O-Ring Seal                                      |
| 2. Tank Screws (4) | 4. Use Screwdriver to pry tank away from pump head. |

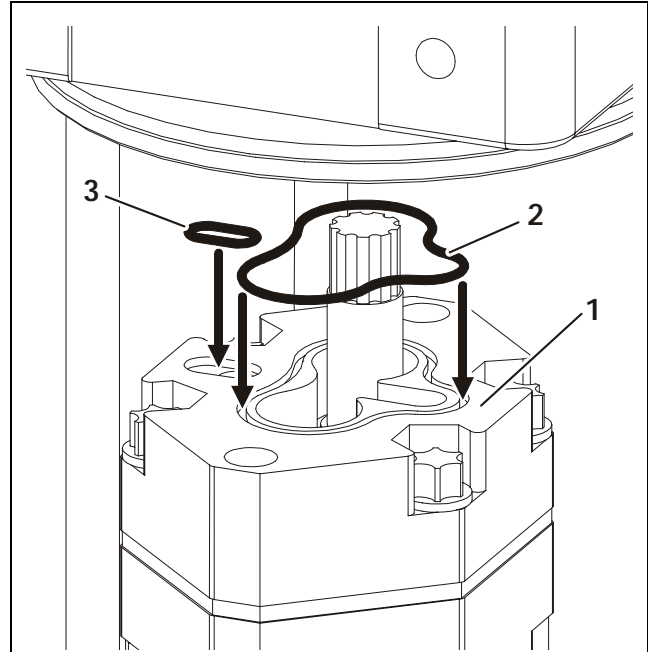

**Pump O-Ring Installation**

- |                  |                |                |
|------------------|----------------|----------------|
| 1. Pump Assembly | 2. O-Ring Seal | 3. O-Ring Seal |
|------------------|----------------|----------------|

### Pump Installation

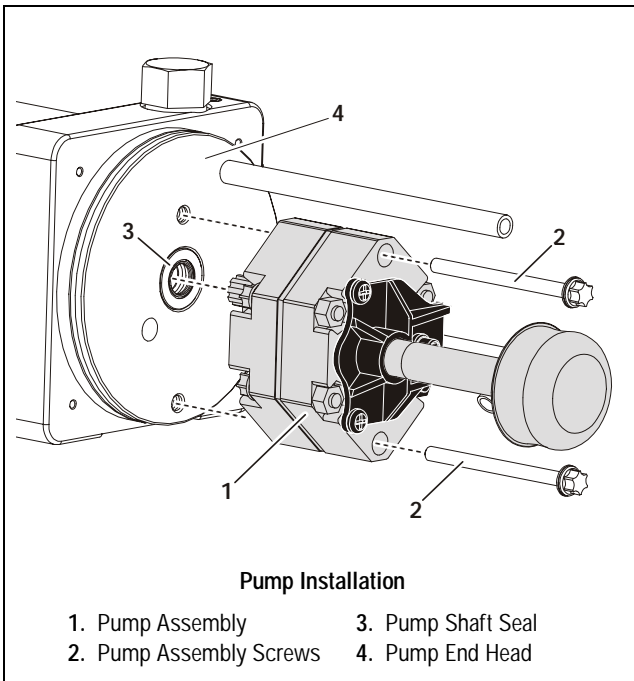

**Pump Installation**

- |                         |                    |
|-------------------------|--------------------|
| 1. Pump Assembly        | 3. Pump Shaft Seal |
| 2. Pump Assembly Screws | 4. Pump End Head   |

### Filter Screen Installation

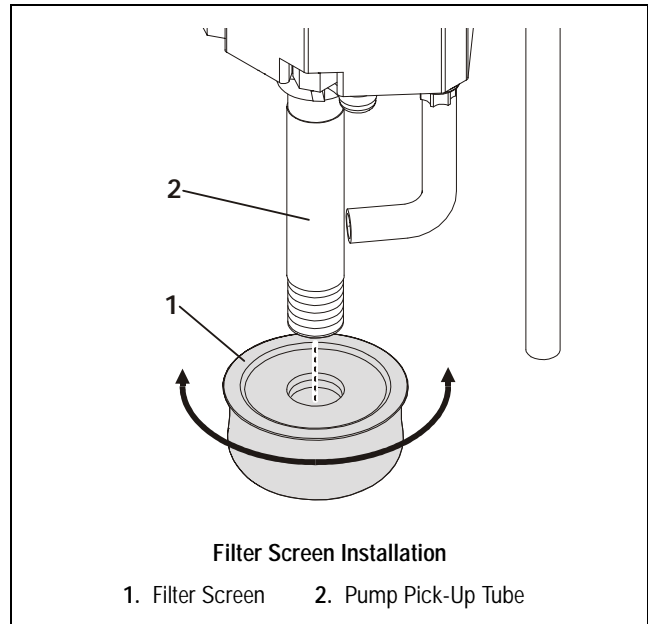

**Filter Screen Installation**

- |                  |                      |
|------------------|----------------------|
| 1. Filter Screen | 2. Pump Pick-Up Tube |
|------------------|----------------------|

**Pressure Adjust Valve Installation**

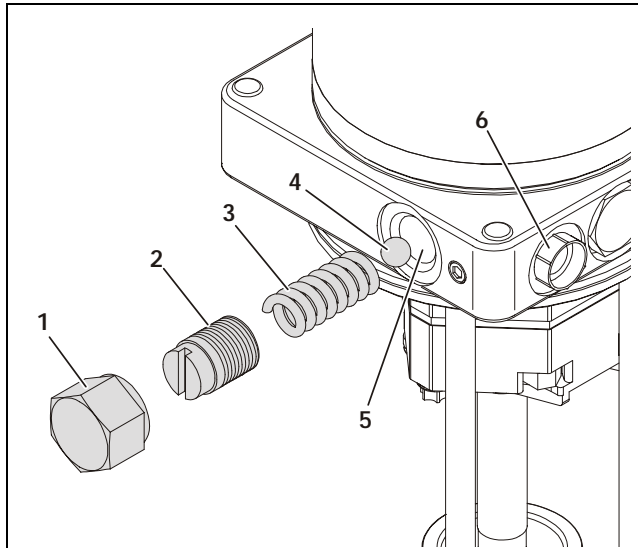

**Pressure Adjust Valve Installation**

- |                     |  |
|---------------------|--|
| 1. Adjust Valve Cap | 4. Valve Ball                                |
| 2. Adjustment Screw | 5. Adjust Valve Port                         |
| 3. Valve Spring     | 6. Extend (Pressure) Port<br>(Shown Plugged) |

*Note: Adjust pressure per specification shown in Section-1 of this Service Manual.*

**Pressure Check Valve Installation**

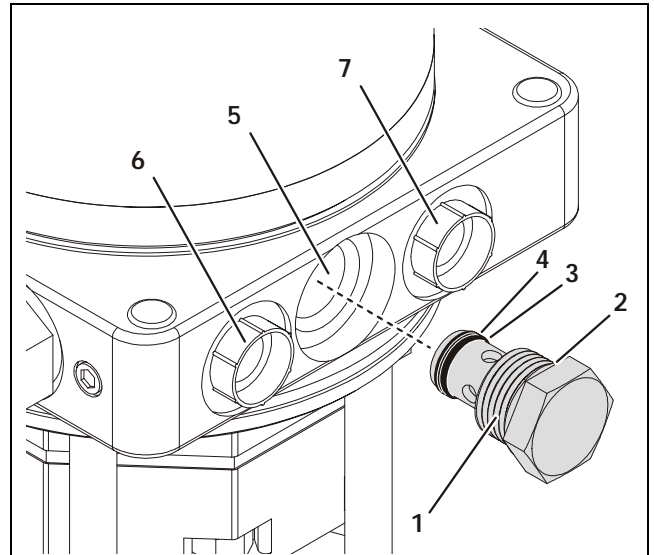

**Pressure Check Valve Installation**

- |                         |                           |
|-------------------------|---------------------------|
| 1. Check Valve Assembly | 5. Check Valve Port       |
| 2. O-Ring Seal          | 6. Extend (Pressure) Port |
| 3. O-Ring Seal          | 7. Return Port            |
| 4. Backing Ring         |                           |

*Note: Extend (Pressure) and Return Ports Shown Plugged*

**4.9 OBSTRUCTION SENSOR SYSTEM - SERVICE PROCEDURE (DVSP - OPTION)**

**General**

The Obstruction Sensor System (OSS) Control Module is mounted between the rails of the mast platform header section under the platform decal billboard at the rear of the DVSP model platform, see illustration below.

The OSS Control Module communicates with the Ground Control Module through the platform electrical junction box also mounted on the mast behind the platform decal billboard.

The OSS Control Module circuit board monitors six (6) channels each channel is wired to an individual transducer sensor mounted under the DVSP model platform. The sensors are mounted in a manner to provide a detection zone

beneath the platform and detect if an object has entered that zone when the platform is being lowered.

**NOTE:** *The OSS only operates normally when the Ground Control Module - Power Selector Switch (Key) is set to PLATFORM CONTROL MODE.*

*When the Power Selector Switch (Key) is set to GROUND CONTROL MODE the OSS will detect an obstruction but will not stop platform downward movement or sound the horn. However, the OSS Control Module LED will flash if a sensor detects the presence of an object.*

An OSS Sensor replacement kit is available from the JLG Parts Department for individual sensors. The kit provides instructions and everything necessary to connect the new sensor to the existing soldered wire ends.

If the OSS Control Module has failed it is recommended to replace the complete OSS system. See Section 6 of this manual for further OSS Troubleshooting instructions.

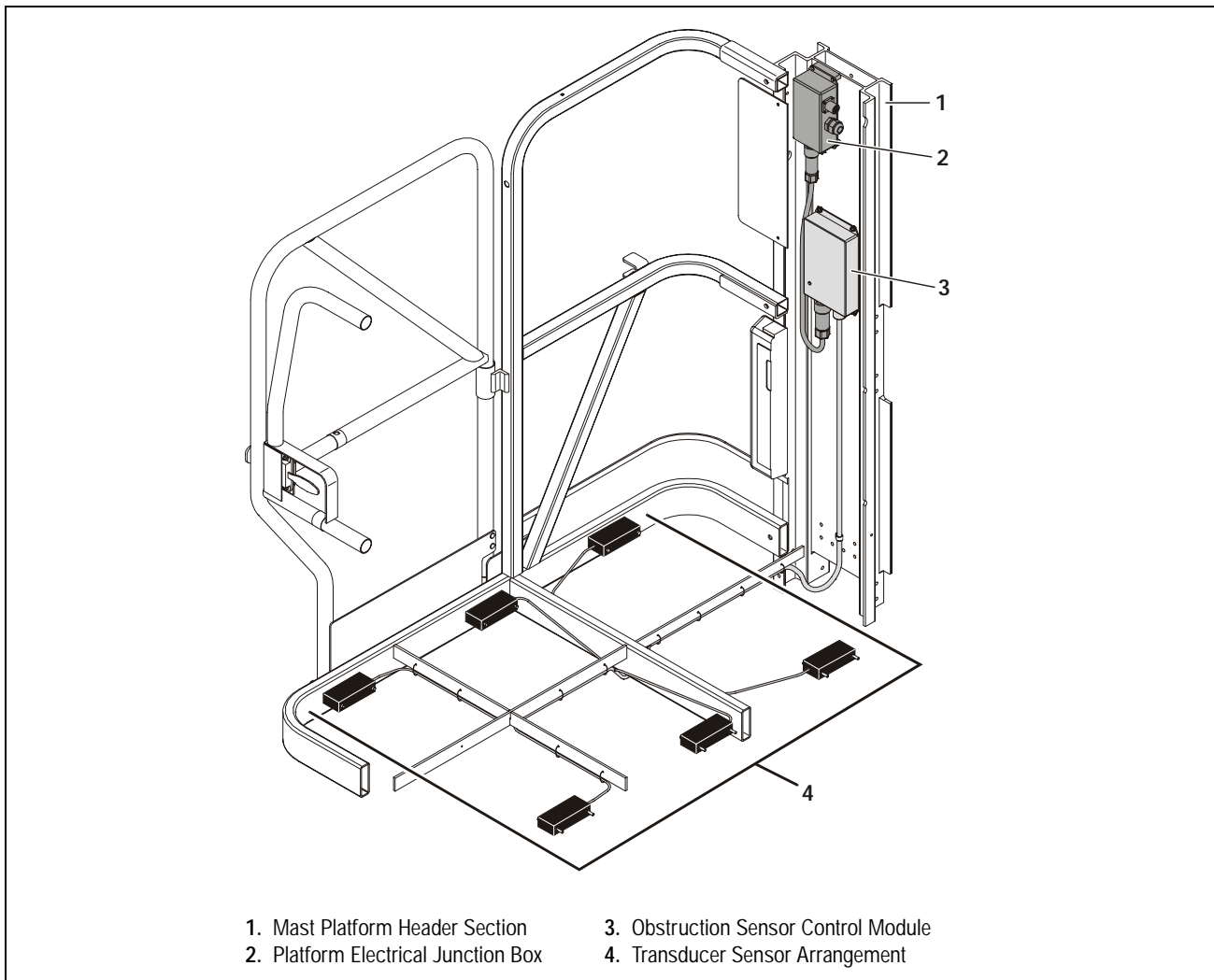

1. Mast Platform Header Section      3. Obstruction Sensor Control Module  
 2. Platform Electrical Junction Box    4. Transducer Sensor Arrangement

**Table 4-2. Obstruction Sensor System Components (Platform Cutaway)**

### Transducer Sensor Check

Perform the following daily Pre-Start Inspection to check if each transducer sensor is working properly.

1. Power up machine by setting the Power Selector (Key) Switch to Ground Control Mode.
2. Raise the platform approximately four (4) to five (5) feet.
3. Hold an object about the size of 8-1/2 x 11 inches directly under one of the sensors. The OSS Control Module (RED) LED will flash if the sensor is working properly.
4. Remove object, allow the LED to stop flashing and check the next sensor, repeat this for all six (6) sensors.

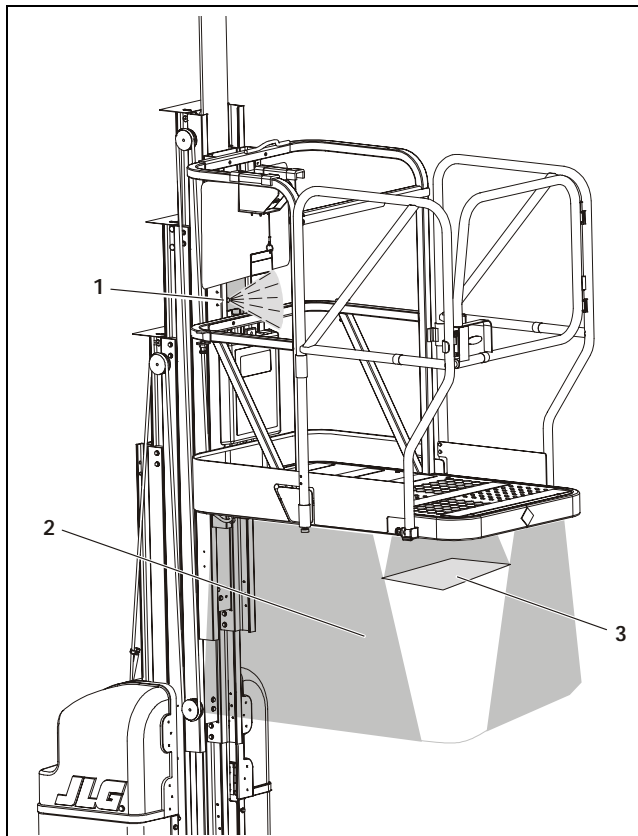

#### Transducer Sensor Check

1. Electronic Module LED Indicator (a)
2. Detection Zone
3. Place a pad of paper or similar size object, 6 to 12 in. (15 to 30cm) individually beneath each transducer to check detection.

Note: (a) The LED Indicator will flash when an object is detected at each sensor. Remove object and allow the LED to stop flashing before testing next sensor.

The Ground Control Module can also display the following sensor detection information when in Level 2 password Service and Maintenance Settings mode.

### OSS Sensor

Displays current Obstruction Sensor System status (Detection - YES/NO). Also if an object is detected, the sensor(s) detecting the object and distance the object is from the sensor is displayed.

1	DETECTION	---	---	---	---	NO
2	1	Øin	0	4	Øin	0
	2	Øin	0	5	Øin	0
3	3	Øin	0	6	Øin	0

#### OSS Sensor LCD Display Mode

1. Detection Indicator - Yes/No
2. Sensor numbers
3. Object distance from sensor
4. Signal strength

Note: This screen can be viewed while another person performs the transducer sensor check, see Section 4.9.

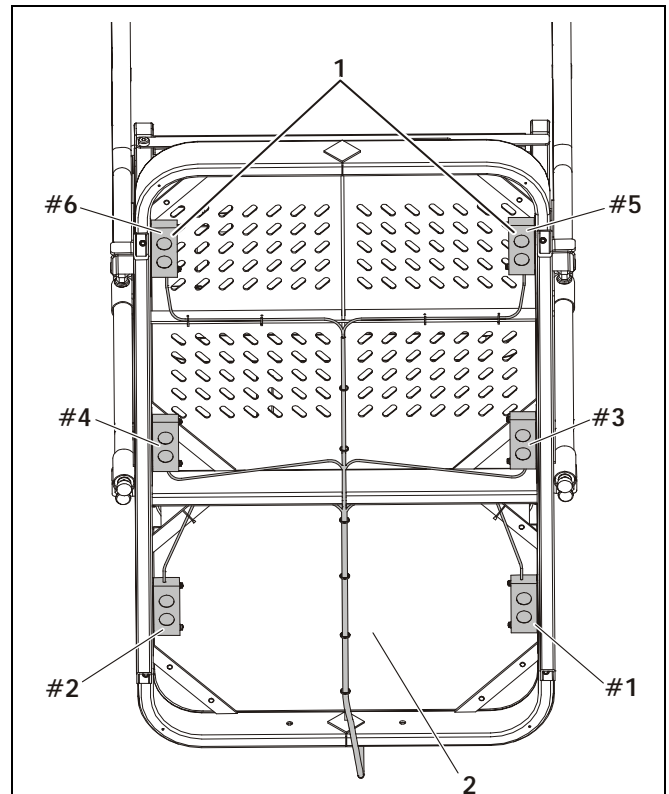

#### Transducer Sensor Locations

1. Transducer Sensors #1 through #6
2. Underside of DVSP Platform

OSS Component Installation

**IMPORTANT**

THE FOLLOWING ILLUSTRATIONS PROVIDE KEY INSTALLATION INSTRUCTIONS FOR THE OSS TO OPERATE PROPERLY.

- The OSS Control Module must be electrically isolated from the mast, see installation instructions.
- The sensor shield tubes attached to the platform's under sides must be properly installed and undamaged to prevent sensor detection of objects outside the platform parameter.
- The area under the platform floor must be free of any objects or debris dangling from beneath the platform to avoid false detection by the sensors.
- DO NOT allow high pressure spray to directly contact the transducer sensor (*circular*) membrane, this will damage the sensor.

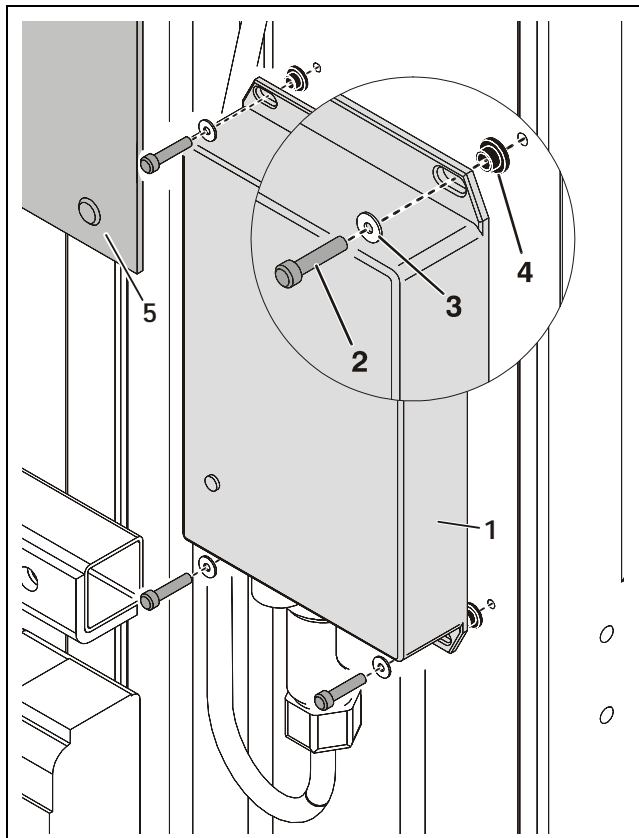

OSS Control Module Installation

- |                       |                        |
|-----------------------|------------------------|
| 1. OSS Control Module | 4. Insulating Bushing  |
| 2. Mounting Screw (a) | 5. Decal Billboard (b) |
| 3. Nylon Washer       |                        |

Notes: (a) Apply Loctite 222 to threads.  
 (b) Drill out pop rivets to remove.

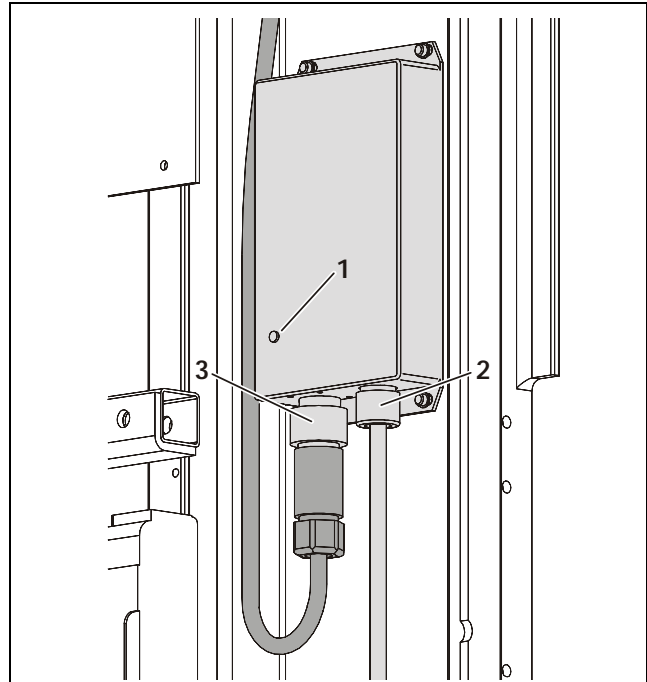

OSS Control Module Connections

- |                                |                         |
|--------------------------------|-------------------------|
| 1. RED LED Detection Indicator | 3. Junction Box Harness |
| 2. Sensor Harness              |                         |

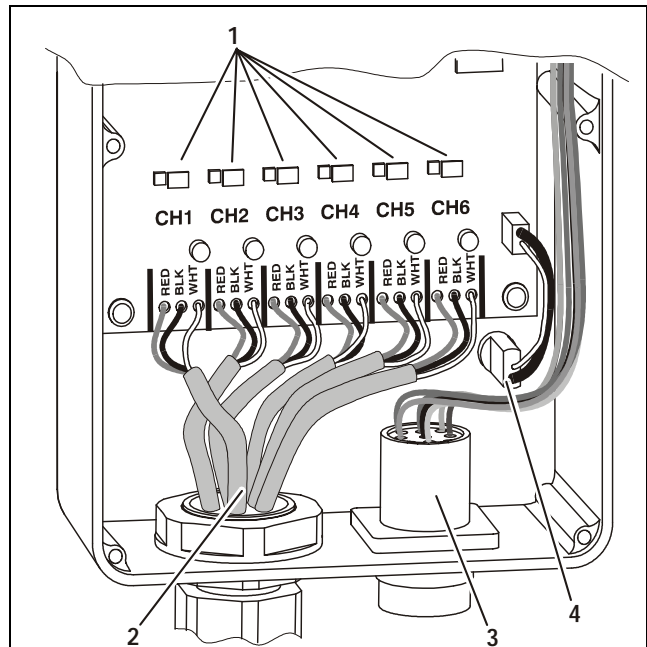

Internal View of OSS Control Module

- |                             |                                   |
|-----------------------------|-----------------------------------|
| 1. Sensor Comm Channels (a) | 3. Wires to Platform Junction Box |
| 2. Sensor Cables            | 4. LED Indicator Light            |

Notes: (a) Channel 1-Sensor 1, Channel 2-Sensor 2, etc.

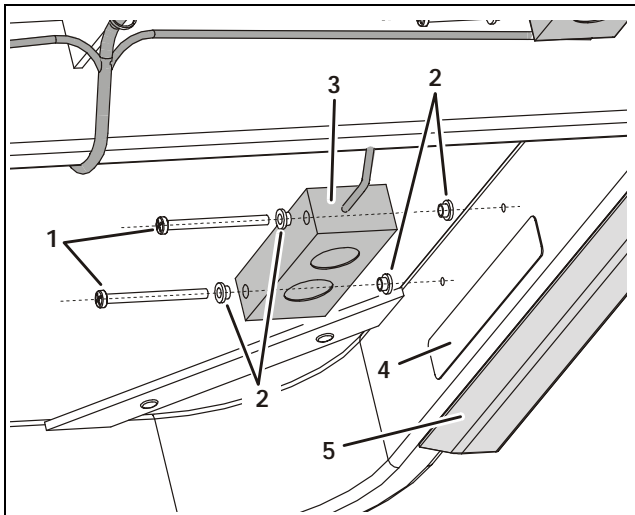

**Transducer Sensor Installation (Typical)**

- 1. Mounting Screws (a)
- 2. Bushings
- 3. Transducer Sensor (b)
- 4. DO NOT Pressure Wash Decal
- 5. Sensor Side Deflector

Notes: (a) Apply Loctite 222 to screw threads and torque to 15 in. lb.  
 (b) Mount sensor with (circular) membrane facing down.

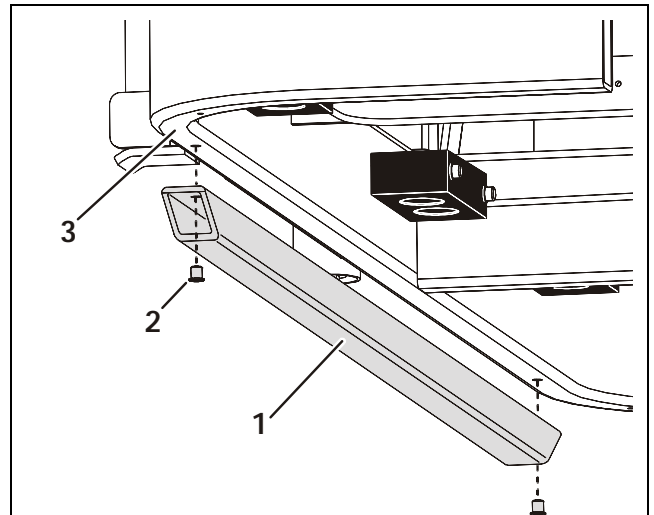

**Sensor Side Deflectors**

- 1. Sensor Side Deflector (a)
- 2. Pop Rivet
- 3. Platform Side Frame

Note: (a) One deflector required on each side of platform. Deflector must be even with, and not extend inside of the platform side frame.

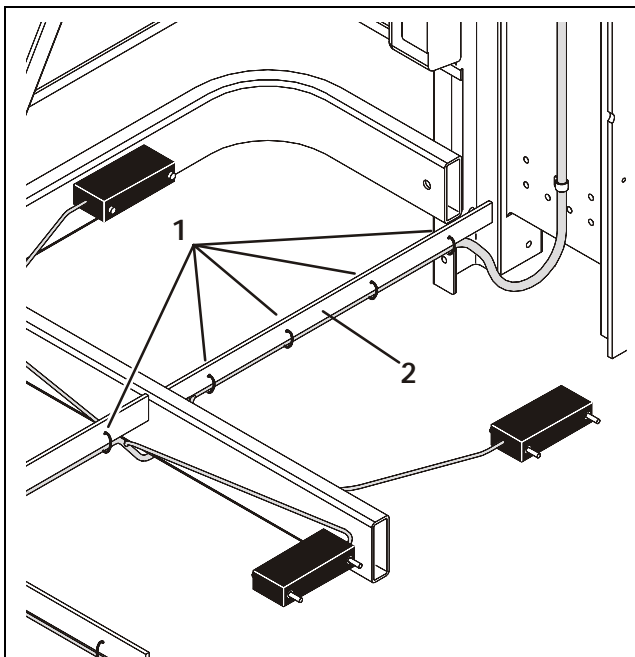

**Secure Transducer Sensor Wiring**

- 1. Nylon Tie Wraps (a)
- 2. Platform Floor Supports

Note: (a) Secure ALL sensor wire cables to platform side frame.

**This page intentionally left blank.**



SECTION 5. MAST COMPONENTS

5.1 MAST COMPONENTS OVERVIEW

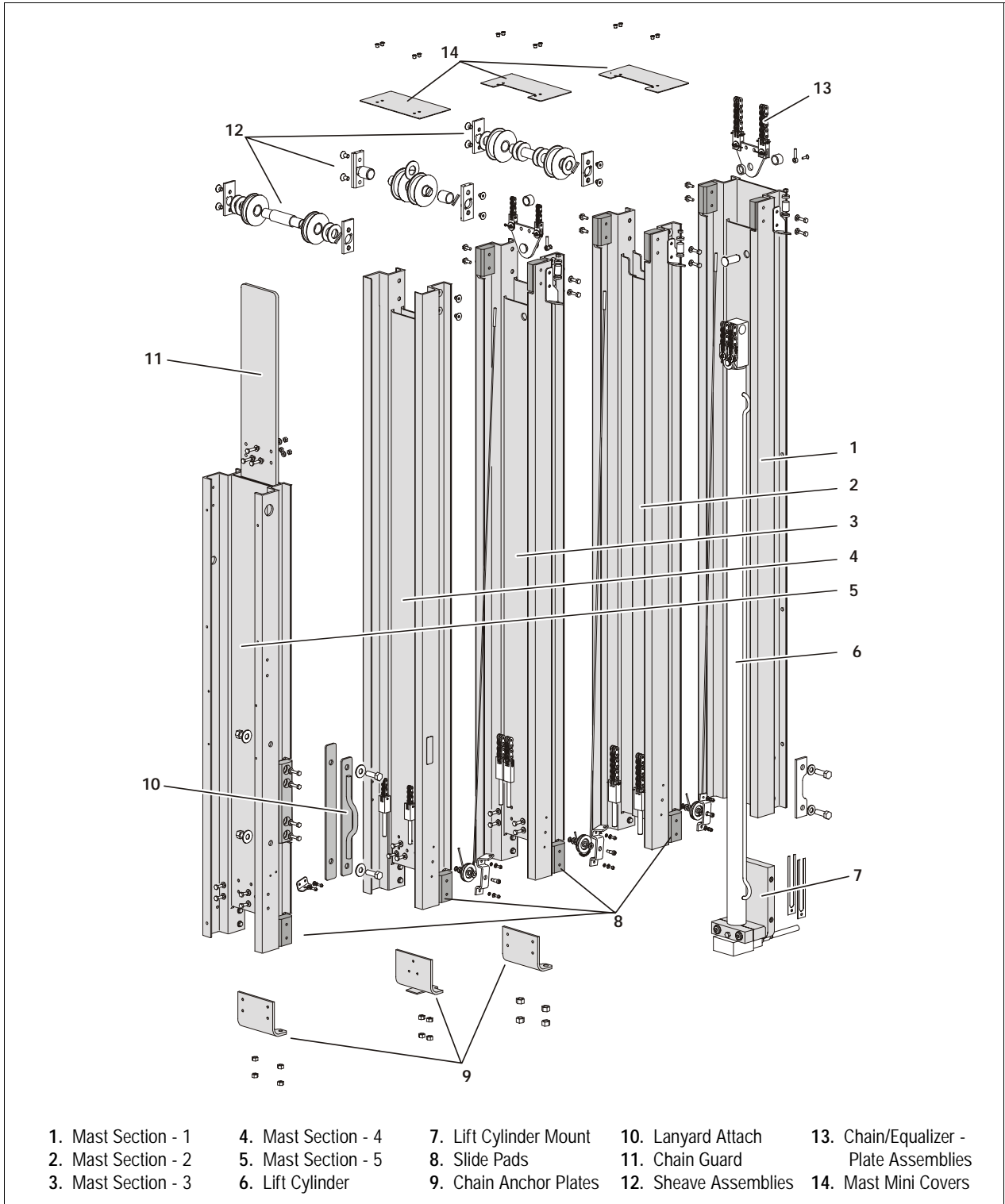

Figure 5-1. Mast Components. (DVL/DVSP)

### 5.2 MAST CHAINS AND SEQUENCING CABLES ADJUSTMENT

#### Mast Chain/Cable Adjustment

The intention of this procedure is to assure equal load distribution between the individual chains of a mast section chain sets. Also to step each front mast section up approximately 7/16 in. (12mm) from the section behind it to allow clearance for the individual mast section covers.

Adjust using the following procedure:

1. With mast retracted, step into the platform and bounce your weight up and down a few times to be certain platform is at the bottom of travel. Be certain all chain/cable sets are seated in their sheaves properly at the top of each mast section.
2. Then with no load in the platform check the side profile of the top of the mast for the amount of adjustment necessary to obtain the 7/16 in. (12mm) step for mast sections-3 and up. (See Illustration)

**NOTE:** Mast section-1 is fixed to the base and mast section-2 is attached to the lift cylinder, these sections require no adjustment.

3. Adjust one mast section at a time starting from the back (section-3, section-4, etc.) of the mast and work forward. (i.e. if three is OK, then jump to four, etc.)
4. To adjust, elevate the platform until the chain/cable anchor adjust nuts are accessible at the front and bottom of each mast section.

#### **WARNING**

**NEVER WORK UNDER AN ELEVATED PLATFORM UNTIL PLATFORM HAS BEEN SAFELY RESTRAINED FROM ANY MOVEMENT BY BLOCKING OR OVERHEAD SLING.**

5. Start with the mast section which needs adjustment and loosen the bottom (*jam*) nut on each chain/cable.

6. Tighten (to raise mast section), or loosen (to lower mast section) the adjusting nut against the anchor plate on each chain/cable. Adjust the nut the amount required to raise or lower the top of the mast section to match the side profile shown in Figure 5-2. when the mast is retracted.

**NOTE:** It is more important that the (threaded ends) studs protruding on the adjustments are equal side to side on a mast section, than it is that the tension in the chains is equal. The chain equalizers will always assure equal tension, but if the adjustment isn't equal as described, the chains may tend to pull to one side or the other.

The threaded end of the chain/cable may need to be restrained while tightening the adjust nut to keep the chain/cable from twisting.

7. Retract the mast all the way and check if the top of the mast sections appear as shown in Figure 5-2.
8. Repeat steps (1) through (7) for remaining mast sections.
9. Once mast section adjustment is completed, apply loctite #242 to the threads under the (*jam*) nuts that were loosened. Then re-tighten the loosened (*jam*) nuts until tight against the top (*adjust*) nut. Chain/cable should have slight tension but should not be taut.
10. (DVSP Only) After all mast adjustments are complete, if necessary adjust the bumpers on the underside of the stock-picker platform so the platform rests slightly above the base frame when it is lowered and empty.

#### Sequencing Cable Adjustment

1. Retract mast completely, and check each sequencing cable on outside of masts for excessive slack. Adjust only to remove slack from cable.
2. Tighten nylock-nut just enough to remove excessive slack from sequencing cable. The springs should not be compressed more than 25% after adjusting.
3. Run mast through several cycles to verify cable/chain adjustments and ensure no interference exists between chain anchor brackets and mast.

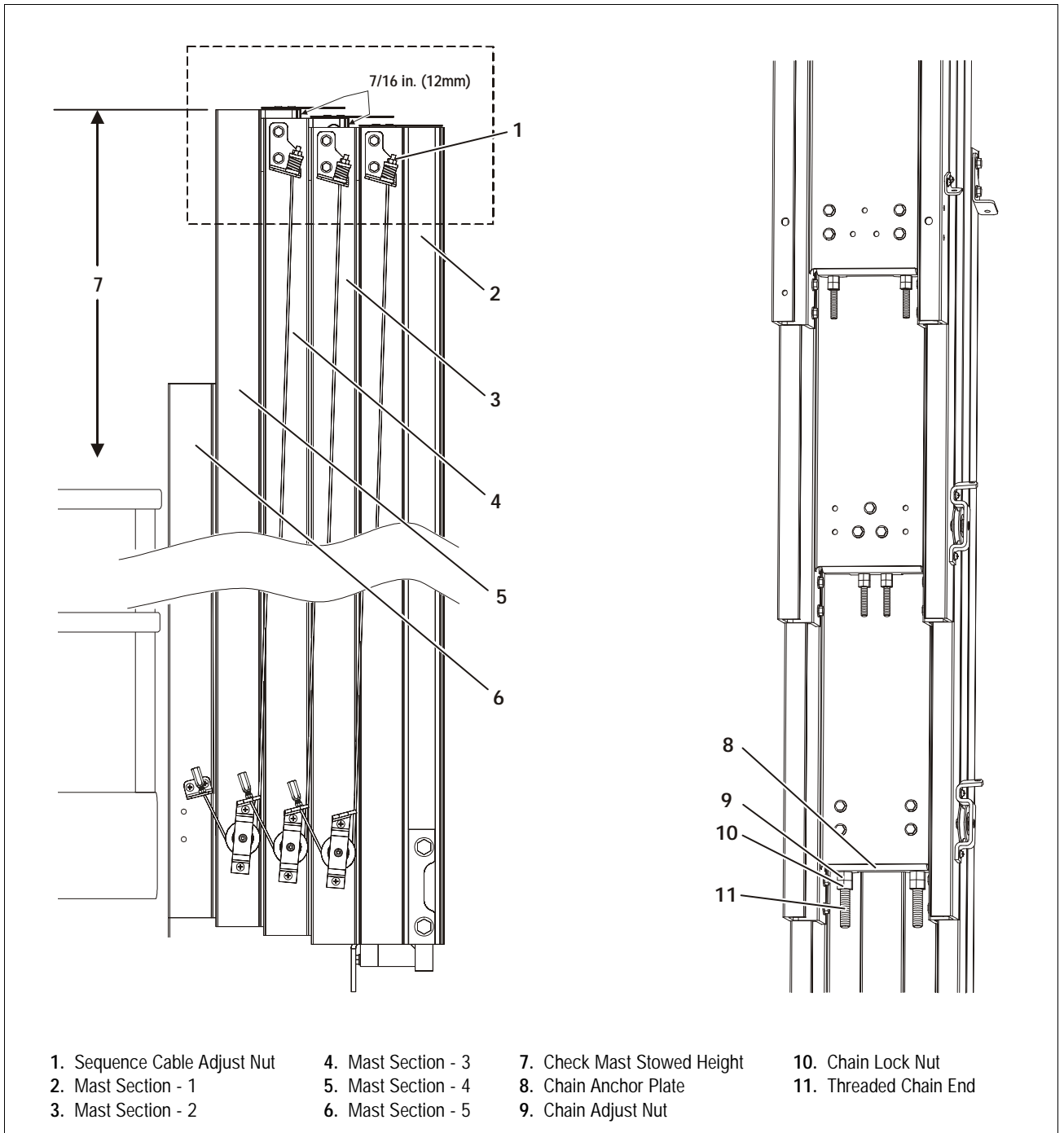

Figure 5-2. DVL/DVSP - Mast Chain and Sequence Cable Adjustment Components.

### 5.3 SEQUENCE CABLE REPLACEMENT KIT

A sequence cable replacement kit is available from the JLG Parts Department to service broken or worn sequence cables. This kit consists of a replacement sequence cable with the threaded (top) end attached same as the top end of the factory cable. Also included is a clamp (drum/socket type) to secure the bottom end of the cable. Use the following procedure to install the replacement cable and clamp kit.

#### Remove Old Cable

1. Remove the locking nut from the threaded end of the cable at the top of the mast and then remove the spring cap, spring, and spacer washers if installed.
2. Slide the threaded top end out of the upper anchor bracket, then at the bottom end pull the cable out through the sheave pulley/anchor bracket until it is completely clear of the machine.

#### Replacement Cable Installation

1. Be certain the mast is completely retracted and at the bottom of travel. Check the mast "Side Profile" at the top of the mast as shown in Figure 5-2., adjust mast sections to proper height if necessary.
2. To determine where the clamp will be installed at the bottom of the replacement cable, temporarily assemble the new replacement cable to the top cable anchor bracket on the mast using the washers, spring, spring cap and lock nut previously disassembled. Thread the lock nut on until approximately 1/8 in. (3mm) of threads are exposed.
3. At the bottom of the mast, thread the loose end of the replacement cable through the proper sheave pulley and through the hole in the sheave pulley/anchor bracket on the mast section ahead of the sheave pulley.
4. Grasp the cable and pull on the cable until the spring at the top of the cable is slightly compressed. Use a black marker to mark the cable on the top side of the sheave pulley/anchor bracket. This will determine where the clamp (drum/socket) sleeve will be positioned on the cable.

#### IMPORTANT

DO NOT CUT THE CABLE AT THE MARKED POINT ON THE CABLE THIS IS ONLY USED AS A REFERENCE FOR POSITIONING THE CABLE SLEEVE WHICH WILL REST AGAINST THE ANCHOR BRACKET ONCE INSTALLED.

### Clamp Installation (Drum/Socket Type)

#### IMPORTANT

THE MANUFACTURER OF THE DRUM/SOCKET CLAMP RECOMMENDS THE USE OF THEIR CABLE CLAMP ASSEMBLY KIT (JLG P/N - 7023275) TO ASSEMBLE THE CLAMP TO THE WIRE ROPE. THE KIT CONSISTS OF VISE JAWS TO HOLD THE WIRE ROPE IN A VISE PROPERLY WITHOUT DAMAGING ANY ROPE STRANDS AND A PLUG DRIVER TO DRIVE THE PLUG INTO THE CENTER OF THE WIRE ROPE AND IS ALSO USED TO FORM THE STRANDS OF THE ROPE DURING ASSEMBLY.

**NOTE:** *The tools in the clamp assembly kit may be fabricated if necessary. The vise clamp consists of vise jaws with a hole drilled 1/32 in. smaller than the diameter of the wire rope you are working with (i.e. 1/8 in. rope - 3/32 in. hole.) The plug driver is a metal tube with a hole in the bottom to allow the strands of the wire rope to be shaped after the plug has been tapped into the center of the wire rope.*

1. Using the recommended vise jaws, clamp the wire rope into a vise with the bottom edge of the black mark made on the wire rope resting just above the vise jaws.

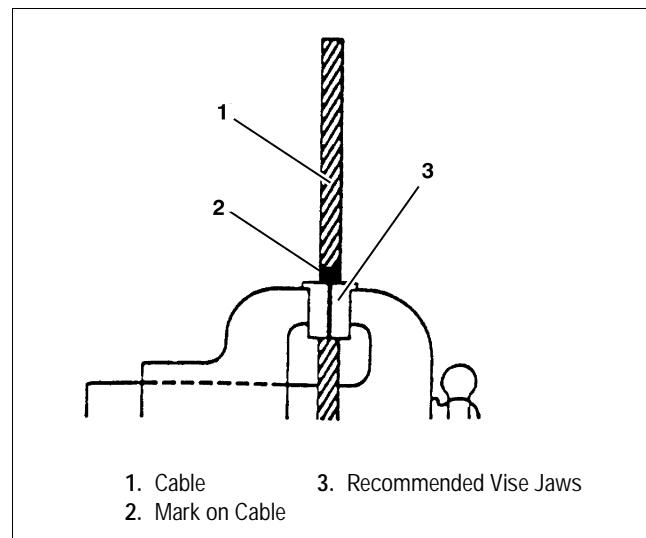

- Twist the sleeve from the clamp kit onto the rope until it is flat against the vise jaws at the mark made on the wire rope.

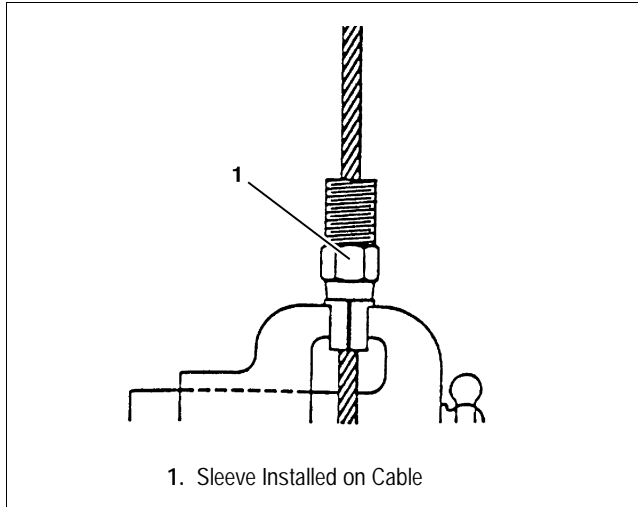

- Use a suitable tool and cut the cable as shown in the illustration following. For 1/8 in. cable the recommended length is 5/8 in. past the end of the sleeve.

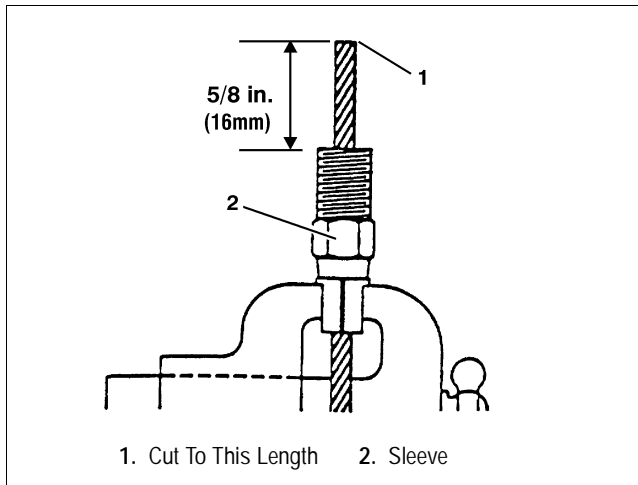

- Unlay the cable strands by gently forcing a screwdriver between the outer strands to unlay the cable. When done properly the outer strands will form a symmetrical basket. Do not straighten out the spiral lay of the strands, unlay any wires that make up the strand, or allow the strands to cross each other inside the sleeve.

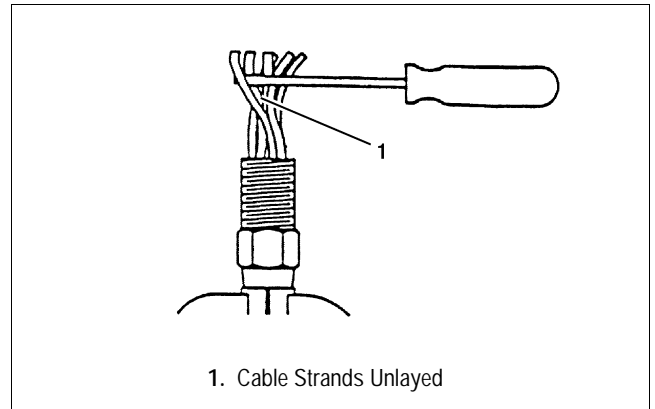

- Install the plug supplied with the kit by placing the plug in the center of the strands starting with the small tapered end of the plug. Use a metal tube (plug driver) and hammer to drive the plug into the sleeve while assuring that the strands are spaced somewhat equally around the plug. Drive the plug until it is firmly seated and no more than 1/3 of the plug is visible from above the sleeve.

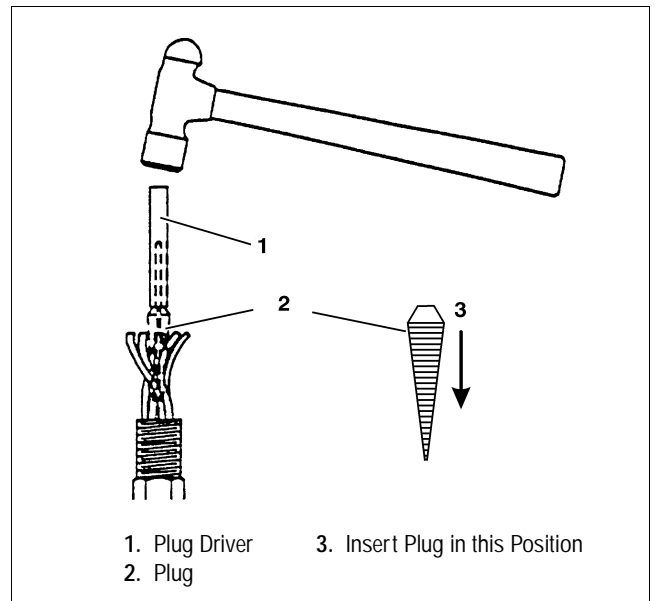

## SECTION 5 - MAST COMPONENTS

6. Reclamp the assembly in the vise on the flats of the sleeve. Using the plug driver, a metal tube or pliers, bend the outer strands toward the center strands enough that the socket can be slipped over all the strands.

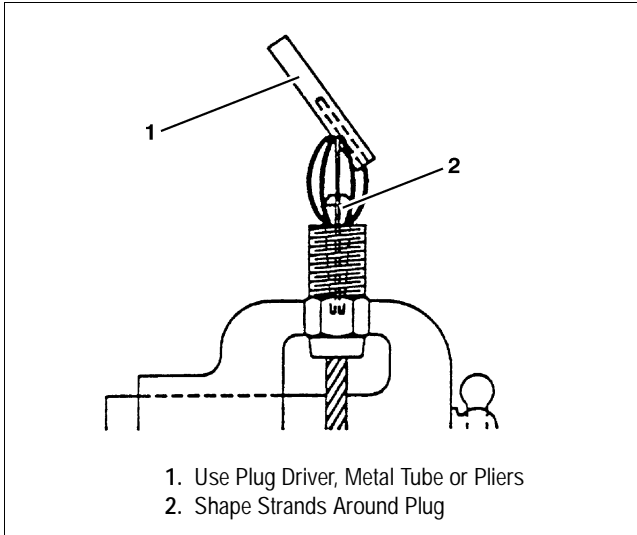

**NOTE:** When assembling stainless steel parts all threads must be coated with a dry lubricant or an anti-seize lubricant to prevent seizing.

7. Coat the threads of the socket and sleeve with lubricant and install the socket by twisting it over the strands of the cable and engage the threads of the sleeve with the socket. Tighten until four threads or fewer are visible. If more than four threads are visible, proof load the cable and retighten the socket fitting. (There is no specific requirement for torque.)

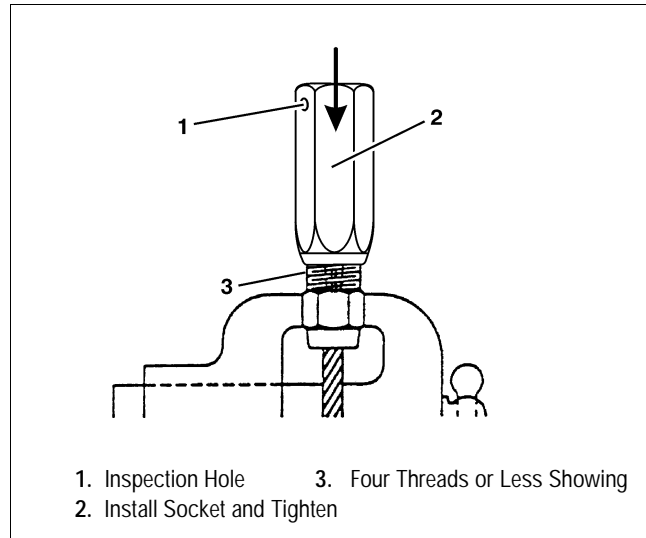

8. Inspect for proper assembly prior to loading the cable. Strands visible through the inspection hole are your assurance of a proper assembly.

**NOTE:** The end of the rope may not be visible in the inspection hole after loading.

9. Install cable on machine and adjust per instructions shown previously in Section 5.2, MAST CHAINS AND SEQUENCING CABLES ADJUSTMENT.

## 5.4 HYDRAULIC LIFT CYLINDER - REMOVAL, INSPECTION AND REBUILD

### **⚠ WARNING**

HYDRAULIC CYLINDERS ARE DESIGNED TO HOLD HYDRAULIC FLUID UNDER HIGH PRESSURE. ENSURE ALL APPROPRIATE MEASURES ARE TAKEN TO RELIEVE RESIDUAL PRESSURE IN THE CYLINDER BEFORE DISCONNECTING LINES.

### Lift Cylinder Removal

Removal of the hydraulic lift cylinder without removing the mast from the machine requires laying the machine on it's back (hood side) with the platform end on top.

1. Remove the following components from the machine before laying machine on it's back:
  - Rear Covers (See Section 4)
  - Batteries (See Section 4)
  - Drive Motor Cover (See Section 3)
2. Seal the vented cap on the hydraulic fluid reservoir by removing the cap, covering the hole with a few layers of plastic wrap or equivalent. Then install and tighten the cap over the plastic wrap to prevent leakage of hydraulic oil from the reservoir while machine is in a layed back position.
3. Use a forklift truck or overhead crane and carefully lay the machine on it's back, place a support under the mast end, keeping mast close to level. (See Figure 5-3.)

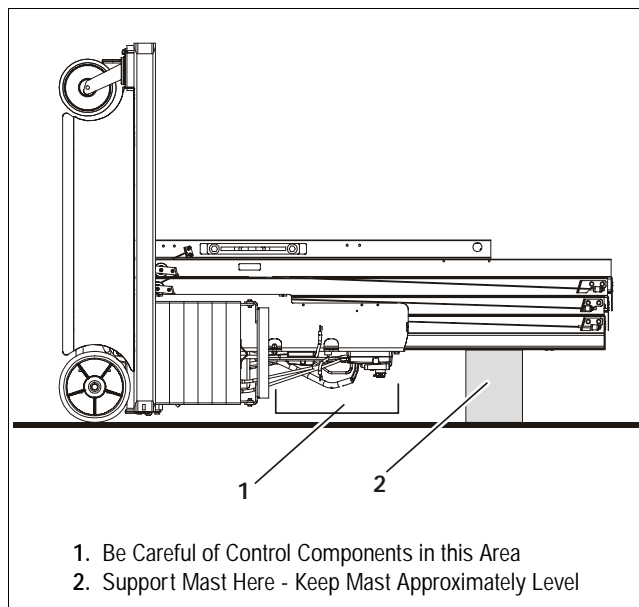
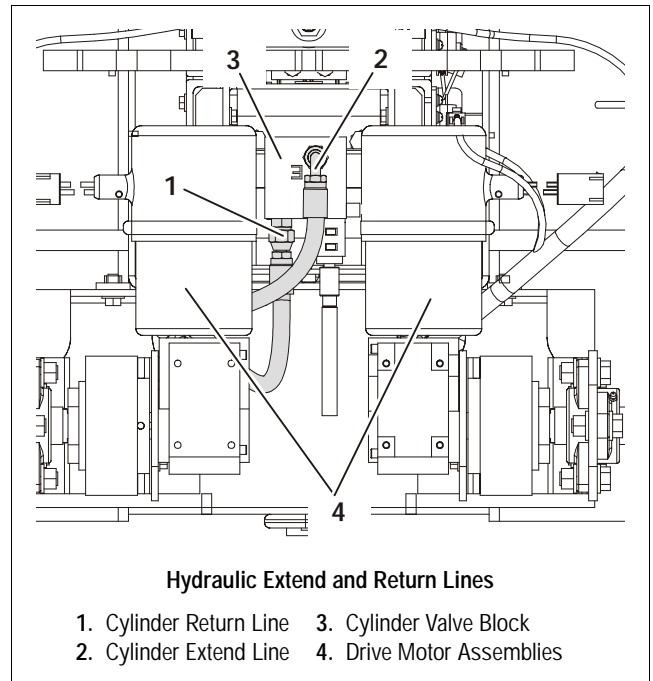
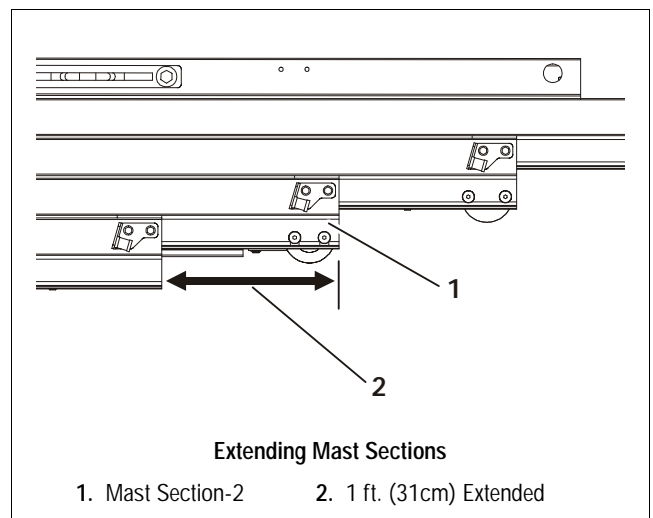

Figure 5-3. Machine Positioned for Cylinder Removal.

4. At the base end, remove and cap the extend and return hydraulic lines.



5. Remove the mini covers from the tops of the mast sections.
6. Manually extend the mast assembly until the top of mast section-2 is extended approximately one (1) foot (31cm), to allow access to the sheave wheel-anchor block at the top of mast section-2 and the lift cylinder.



## SECTION 5 - MAST COMPONENTS

7. Remove the adjust and lock nuts from the chain studs at the bottom of mast section-3.

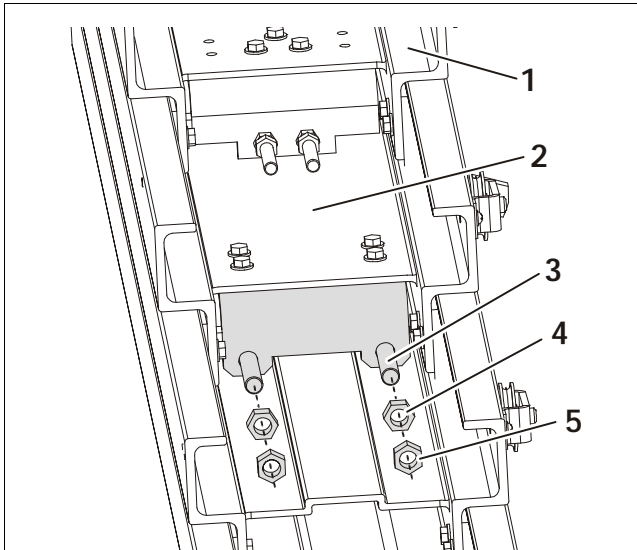

**Chain Assembly - Bottom of Mast Section-3**

- |                            |                 |
|----------------------------|-----------------|
| 1. Mast Section-4          | 4. Adjust Nut   |
| 2. Mast Section-3          | 5. Lock Nut (b) |
| 3. Chain Assembly Stud (a) |                 |

Note: (a) Remove nuts and push studs through anchor plate.

8. Push mast sections-3, 4 and 5 back towards the base assembly allowing the top of mast section-2 to be completely exposed.

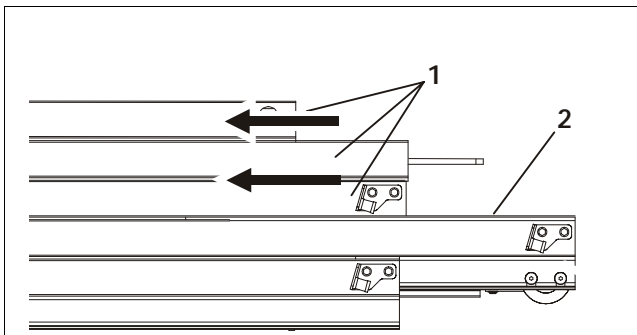

**Exposing Top of Mast Section-2**

- |                                    |
|------------------------------------|
| 1. Sections-3, 4 and 5 Pushed Back |
| 2. Top of Mast Section-2 Exposed   |

9. Remove the cylinder/anchor block attach pin - snap ring from the back of the top of mast section-2.

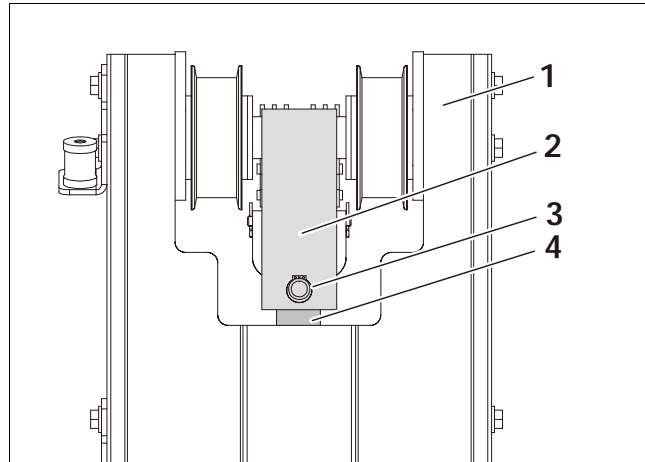

**Snap Ring Installation**

- |                            |                      |
|----------------------------|----------------------|
| 1. Back of Mast Section-2  | 3. Pin and Snap Ring |
| 2. Cyl./Chain Anchor Block | 4. Cylinder Rod      |

10. Remove the cylinder rod pin from the cylinder/chain anchor block.

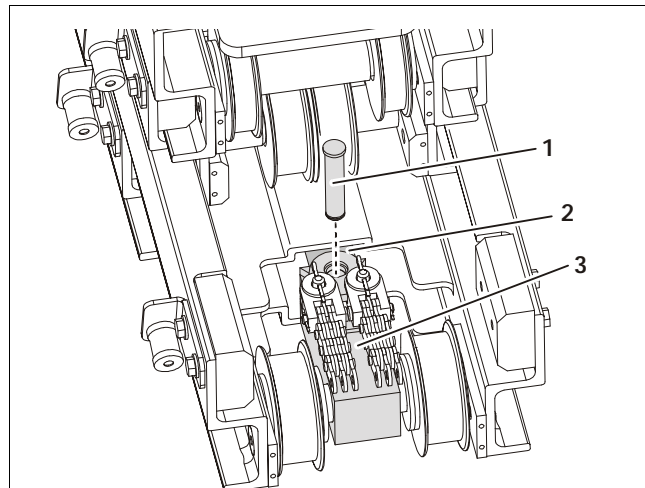

**Cylinder Rod Pin Installation**

- |                     |                            |
|---------------------|----------------------------|
| 1. Cylinder Rod Pin | 3. Cyl./Chain Anchor Block |
| 2. Cylinder Rod     |                            |



11. At the bottom of mast section-1, remove the cylinder mount bolts, and mount reinforcement plates.

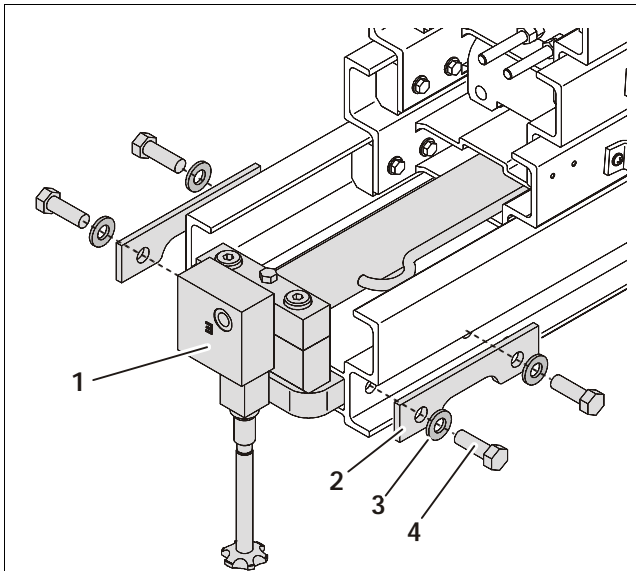

Lift Cylinder Mount Installation

- |                            |                              |
|----------------------------|------------------------------|
| 1. Cylinder/Mount Assembly | 3. Washers                   |
| 2. Reinforcement Plate     | 4. Mount Mounting Screws (a) |

Notes: (a) Apply Loctite #242 to threads at final assembly.

12. Slide the cylinder and mount assembly out of the bottom of mast section-1 and -2 and place on a suitable work surface.

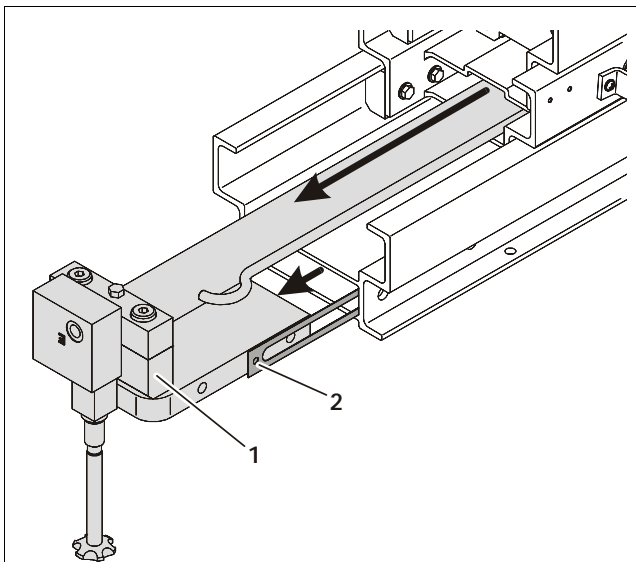

Cylinder Installation

- |   |
|---|
| 1. Lift Cylinder and Cylinder Mount Assembly        |
| 2. Mount Shims (Mark Shim Packs for Reinstallation) |

## Cylinder Disassembly

(See Figure 5-4.)

1. Before disassembling the cylinder, clean away all dirt and foreign substances from openings, particularly the head area.

**NOTE:** Always protect the chrome surface of the cylinder rod during assembly and disassembly. Any damage to this surface will require replacement of the rod.

2. Extend the rod until the piston bottoms out against the cylinder head.
3. Compress the head retaining ring enough to allow the cylinder head to be removed.
4. Carefully slide the head/rod/piston assembly out of the cylinder tube. A gentle tap on the head assembly may be required to remove the head from the cylinder tube.
5. Place the head/rod/piston assembly on a surface that will not damage the chrome.
6. Remove the piston locknut and separate the piston from the rod.
7. Slide the head off the rod from the piston end.

**NOTE:** When removing the old seals use only blunt tools, be sure there are no sharp edges that may damage the seal grooves during removal. Scratching the groove may cause by-pass.

8. Remove and discard all old seals.

## Lift Cylinder Component Inspection

### Cylinder Rod

There should be no scratches or pits deep enough to catch the fingernail. Pits that go to the base metal are unacceptable. Scratches that catch the fingernail but are not to the base metal, less than 0.5 inch long and primarily in the circumferential direction are acceptable provided they cannot cut the rod seal. Chrome should be present over the entire surface of the rod and the lack thereof is unacceptable. In the event that an unacceptable condition occurs, the rod should be repaired or replaced.

### Cylinder Head

Visually inspect the inside bore for scratches or polishing. Deep scratches are unacceptable. Polishing indicates uneven loading and when this occurs, the bore should be checked for out-of-roundness. If out-of-roundness exceed 0.007", this is unacceptable. Check the condition of the dynamic seals (wiper, rod seals) looking particularly for metallic particles embedded in the seal surface. It is normal to cut the static seal on the retaining ring groove upon disassembly. Remove the rod seal, static o-ring and backup and

## SECTION 5 - MAST COMPONENTS

rod wiper. Damage to the seal grooves, particularly on the sealing surfaces, is unacceptable. In the event that an unacceptable condition occurs, the head should be replaced.

### Piston

Visually inspect the outside surface for scratches or polishing. Deep scratches are unacceptable. Polishing indicates uneven loading and when this occurs, the diameter should be checked for out-of-roundness. If out-of-roundness exceeds 0.007", this is unacceptable. Check the condition of the dynamic seals and bearings looking particularly for metallic particles embedded in the bearing and in the piston seal surface. Remove the seals and bearings. Damage to the seal grooves, particularly on the sealing surfaces, is unacceptable. In the event that an unacceptable condition occurs, the piston should be replaced.

### Tube Assembly

Visually inspect the inside bore for scratches and pits. There should be no scratches or pits deep enough to catch the fingernail. Scratches that catch the fingernail but are less than 0.5 inch long and primarily in the circumferential direction are acceptable provided they cannot cut the piston seal. The roughness of the bore should be between 10 and 20  $\mu$  inches RMS. Significant variation (greater than 8  $\mu$  inches difference) are unacceptable. In the event that an unacceptable condition occurs, the tube assembly should be repaired or replaced.

### Cylinder Assembly

(See Figure 5-4.)

1. Rinse the inside of the tube with hydraulic fluid and allow to drain. A high-pressure rinse followed by a wipe with a lint-free rag is preferable. Clean all internal components of any foreign material.
2. Lubricate the head and all seals with hydraulic fluid prior to installation. Install the seal, wiper, o-ring, back-up ring, and retraining ring to the cylinder head.
3. Lubricate the piston and all components with hydraulic fluid. Install the seal and wear ring to the piston.

**NOTE:** Re-check that seals are not twisted or pinched and are properly seated.

4. Place the rod on a clean table. Install the static piston o-ring seal into the groove on the piston end of the rod.
5. Install the head followed by the piston onto the rod noting the proper orientation of each component. Torque the piston nut to 100-120 ft. lbs.

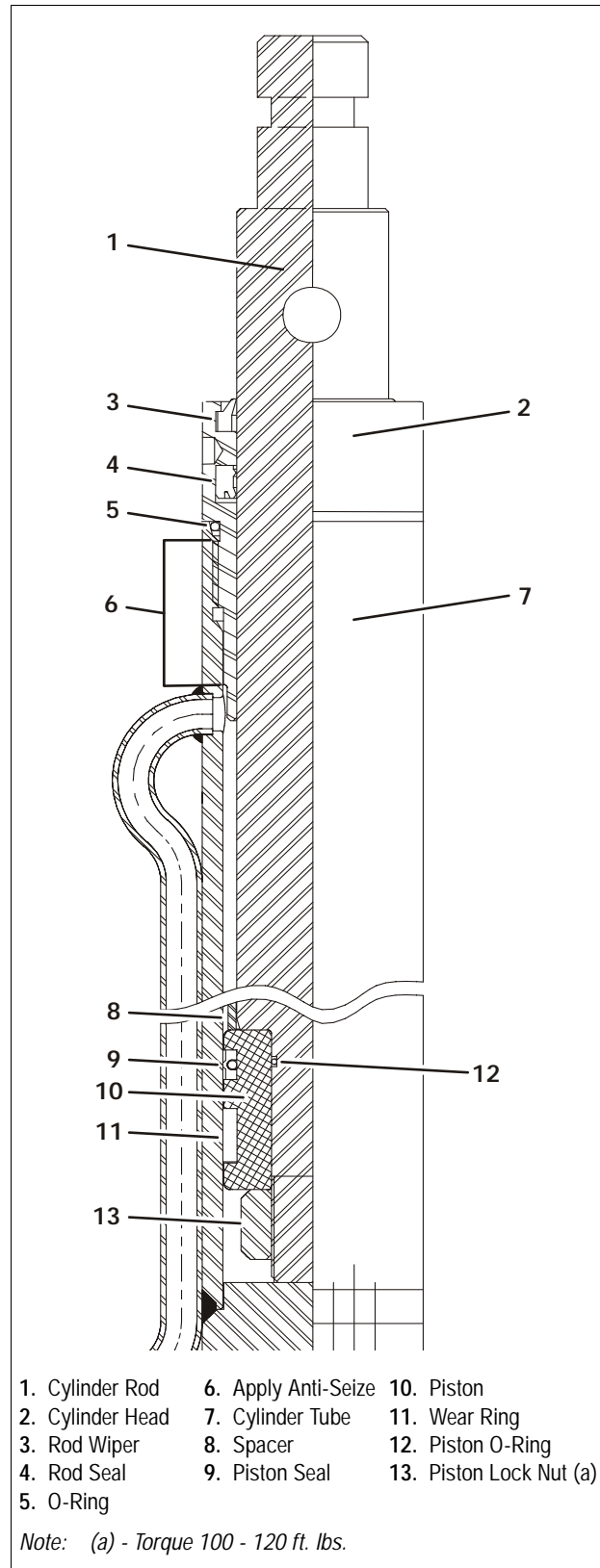
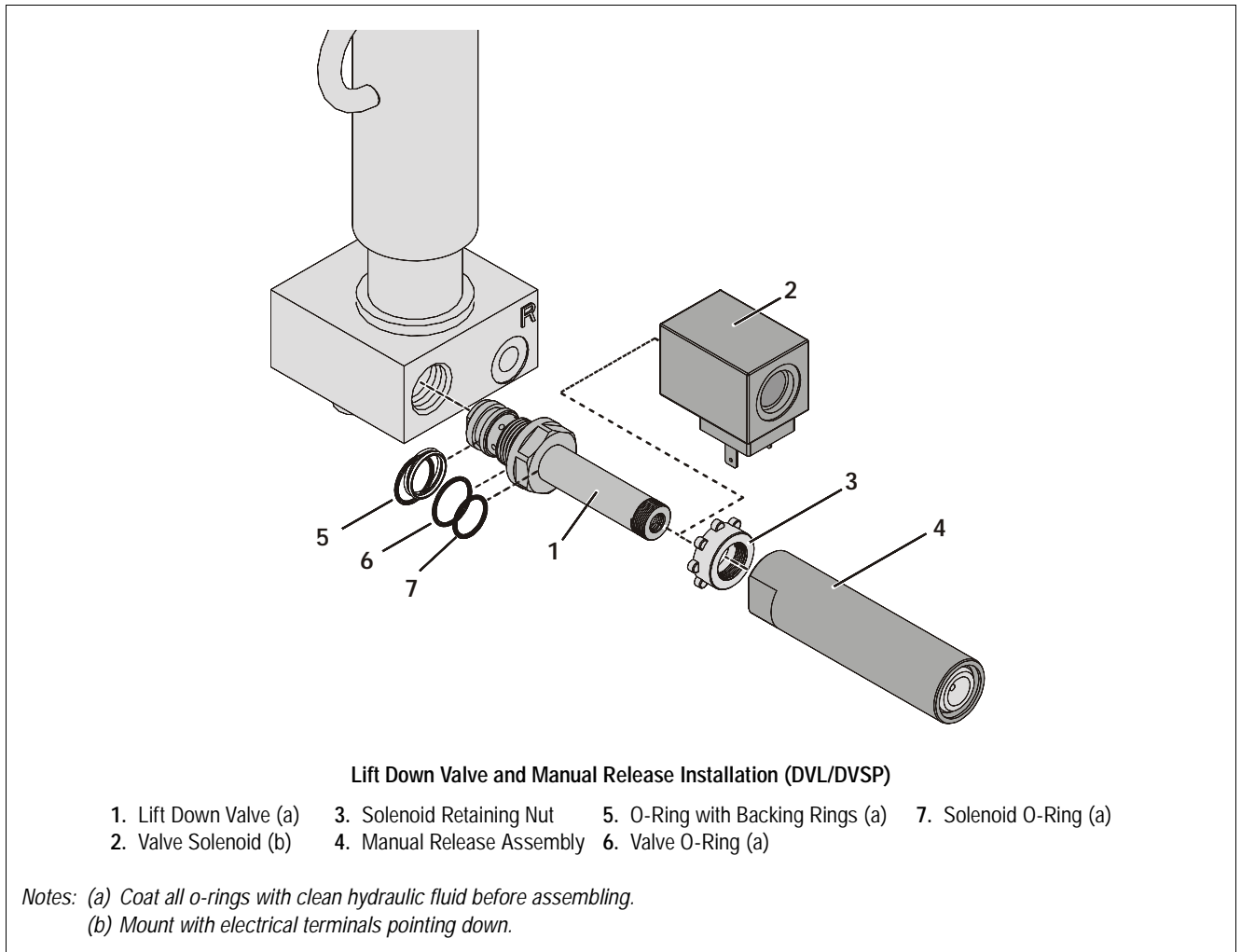

Figure 5-4. Lift Cylinder Component Cross-Section (DVL/DVSP).



6. When the rod assembly is ready to be installed into the tube, liberally apply an anti-seize lubricant to the cylinder head surface which slides into the cylinder tube.
7. Next dip the entire rod assembly into hydraulic fluid and stuff this assembly into the tube. Watch the seals as they pass over the rod port (*if visible*) to be sure they are not nicked or cut.
8. Install the head until the retaining ring seats in it's groove.

### Cylinder Installation

To install the lift cylinder reverse the Lift Cylinder Removal instructions at the start of this section, however perform the following additional steps during re-assembly.

1. Apply Loctite #222 (purple) and torque to 85 ft. lbs. the cylinder mount shoulder screws securing the lift cylinder mount halves together at the bottom of the mast.
2. Check that the platform electrical control cables and the sequence cables are seated in their sheave wheel assemblies when extending mast sections for reassembly.
3. After assembly, readjust the chain at the bottom of mast section-3 and apply Loctite #242 to the lock nuts before final tightening.
4. Remove the plastic from under the hydraulic reservoir tank cap.

## 5.5 MAST ASSEMBLY INSTALLATION

### Mast Removal

5. The following components must be removed from the machine before removing the mast assembly:
  - Rear Covers
  - Drive Motor Cover
  - Disconnect the Platform Control Console from the Mast mounted junction box
  - Platform Assembly
6. Disconnect the positive battery cable from the left side battery.
7. Unplug the platform control cable connector at the ground control module.
8. Remove the clamp attaching the platform control cable from inside the mast mounting column.
9. Disconnect the spring and clamp attaching the AC receptacle cable inside the mast mounting column.
10. Under the machine, disconnect and cap the hydraulic extend and return lines from the hydraulic cylinder.
11. Using an overhead crane or suitable lifting device capable of supporting the weight of the mast assembly, attach a sling strap to the mast. *(If installed, use the optional crane lifting lug on the back of the mast.)*
12. Remove the six (6) mast attach bolts with washers and nuts securing the mast to the mounting column.
13. Lift the mast off the base frame and place on a suitable work surface.

### Mast Installation

To install the mast assembly reverse the Mast Assembly Removal instructions, however perform the following additional steps during re-assembly.

1. Install machine covers per instructions Section 3.
2. Once assembly is complete cycle the mast up and down several times, then check the oil level in the hydraulic reservoir.

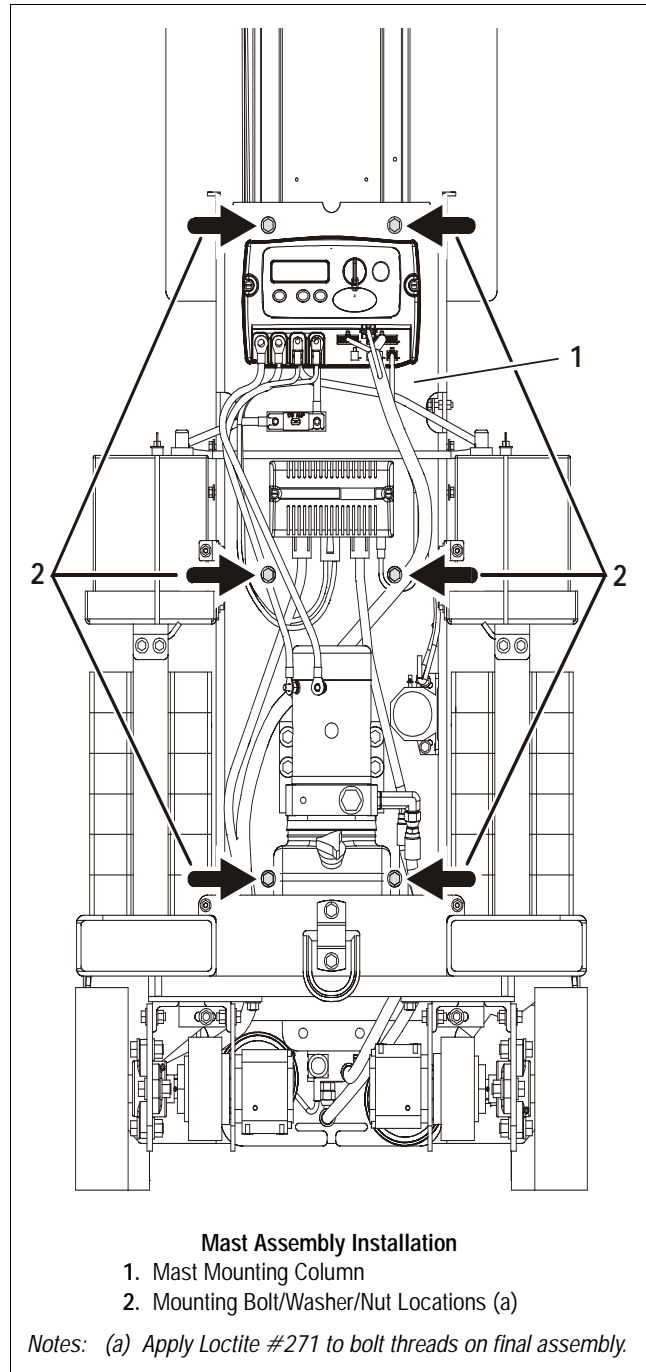

**5.6 MAST ASSEMBLY AND DISASSEMBLY PROCEDURES**

The DVL/DVSP lift mast sections are constructed of extruded aluminum, protected with an anodized surface finish. The mast sections are interlocked into each other when assembled, by internally mounted slide pads at the top and bottom of each mast section. These slide pads run up and down in slide pad channels on each side of the mast.

The DVL/DVSP model mast assembly contains a different number of mast sections as shown following:

**Table 5-1. DVL/DVSP Mast Component Features**

Model	No. of Mast Sections	Extend/Retract Device
DVL Series & DVSP	5	Chain

Assembly procedures for all mast sections is basically the same, carefully slide the mast sections together until mast ends are even. *(When sliding the mast sections together, be careful not to scratch the anodized surface).* Assemble the hardware to the bottom of mast section first, slide this section out the top of previous section and assemble hardware to the top of mast. Always install slide pad shims with slide

pads inserted into the slide pad channels, *(ends of mast sections even)*. Applying silicone spray onto the slide pads and slide pad channels before assembly will help mast sections slide easier after slide pads have been properly shimmed.

**Mast Disassembly Procedure**

1. After the mast assembly has been removed from the machine, lay the mast assembly down on a suitable work table with the platform mounting section on top, facing up.
2. Remove the sequencing cables and hardware from the sides of the mast assembly. Also remove the covers from the top of the mast assembly.

**MAST SECTION-5 - REMOVAL**

3. Remove chain adjust nuts from threaded ends of chain attached to the chain anchor plate *(lower)* on BOTTOM end of mast section-5 *(platform mounting section)*. Push threaded ends of chain through anchor plate.
4. At the TOP of mast section-5, pull chains out and allow to hang loose. *(Be certain floor surface is clean and free of any metal chips or debris which may stick to lubricated chains)*

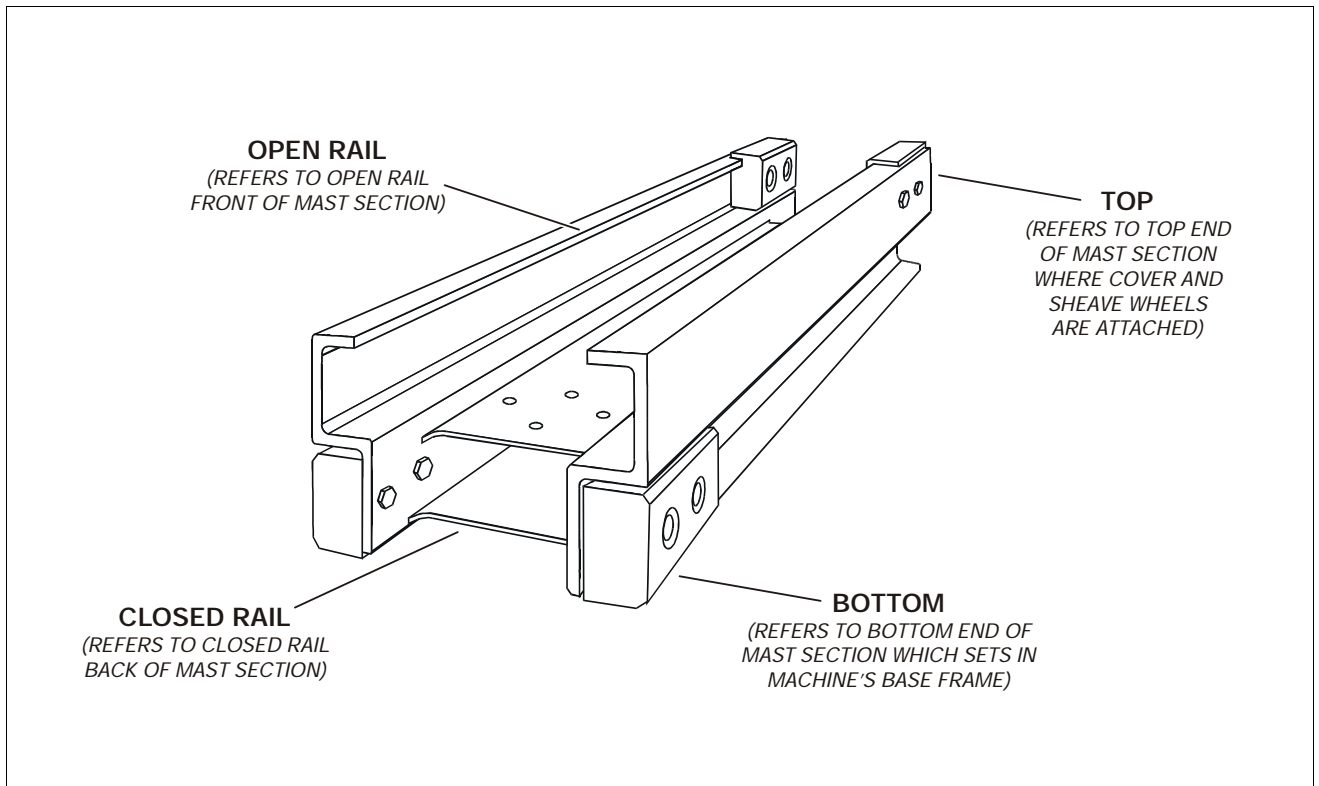

**Figure 5-5. Mast Section - Assembly Reference.**

## SECTION 5 - MAST COMPONENTS

---

**NOTE:** When sliding mast sections apart, be careful not to scratch or score the anodized surface in the slide pad channels.

5. Carefully slide mast section-5 out the BOTTOM of mast section-4 rails. Disassemble slide pads, shims and chain anchor plate from mast section-5, if necessary.

### MAST SECTION-4 - REMOVAL

6. Remove chain adjust nuts from threaded ends of chains attached to the chain anchor plate (lower) on BOTTOM end of mast section-4. Push threaded ends of chains through anchor plate.
7. At TOP of mast section-4, pull chains out and allow to hang loose. *(Be certain floor surface is clean and free of any metal chips or debris which may stick to lubricated chains)*
8. Slide mast section-4 out the TOP of mast section-3 far enough to allow access to the chain sheave wheel assembly.
9. Remove countersunk-flathead screws securing chain sheave wheel assembly attach bars on both side rails at TOP of mast section-4 and remove sheave wheel assembly.

**NOTE:** When sliding mast sections apart, be careful not to scratch or score the anodized finish in the slide pad channels.

10. Carefully slide mast section-4 out BOTTOM of section-3. Remove slide pads, shims and cable anchor plate, if necessary.

### MAST SECTION-3 - REMOVAL

11. Remove chain adjust nuts from threaded ends of chain attached to the chain anchor plate on BOTTOM end of mast section-3. Push threaded ends of chain through the anchor plate.
12. At TOP of mast section-3, pull chains out and allow to hang loose, *(be certain floor surface is clean and free of any metal chips or debris which may stick to lubricated chains)*.
13. Slide mast section-3 out TOP of mast section-2 far enough to allow access to the chain sheave wheel assembly.
14. Remove countersunk-flathead screws securing chain sheave wheel assembly attach bars on both side rails at TOP of mast section-3 and remove the sheave wheel assembly.
15. While mast section-3 is still extended from section-2 remove the pin attaching the chain anchor plate to the TOP of mast section-3. Remove chains.

**NOTE:** When sliding mast sections apart, be careful not to scratch or score the anodized finish in the slide pad channels.

16. Carefully slide mast section-3 out BOTTOM of section-2. Remove slide pads, and shims, if necessary.

### MAST SECTION-2 - REMOVAL

17. Slide mast section-2 out TOP of mast section-1 far enough to allow access to the chain assembly anchor block/sheave wheel assembly.
18. Remove countersunk-flathead screws securing chain anchor block/sheave wheel assembly attach bars on both side rails at TOP of mast section-2.
19. Slide the chain anchor block/sheave wheel assembly and hydraulic cylinder out the TOP of mast section-2 far enough to allow removal of the sheave wheel attach bars, sheave wheels and sheave pin from chain assembly anchor block.
20. Remove the setscrew holding the hydraulic cylinder rod onto the chain assembly anchor block. Lay chain assembly/anchor block to side.
21. Remove the hydraulic cylinder through BOTTOM of mast section-2, be careful not to nick or score cylinder rod surface while removing.

**NOTE:** When sliding mast sections apart, be careful not to scratch or score the anodized finish in the slide pad channels.

22. Carefully slide mast section-2 out BOTTOM of section-1. Remove slide pads and shims, if necessary.

### MAST SECTION-1 - DISASSEMBLY

23. Slide the TOP of remaining mast section-1 out over edge of work surface and remove the pins attaching the chain anchor block to mast section-1. Remove chain/anchor block assemblies from mast and lay aside.
24. Remove slide pads and shims from mast section-1.

**Mast disassembly should now be complete.**

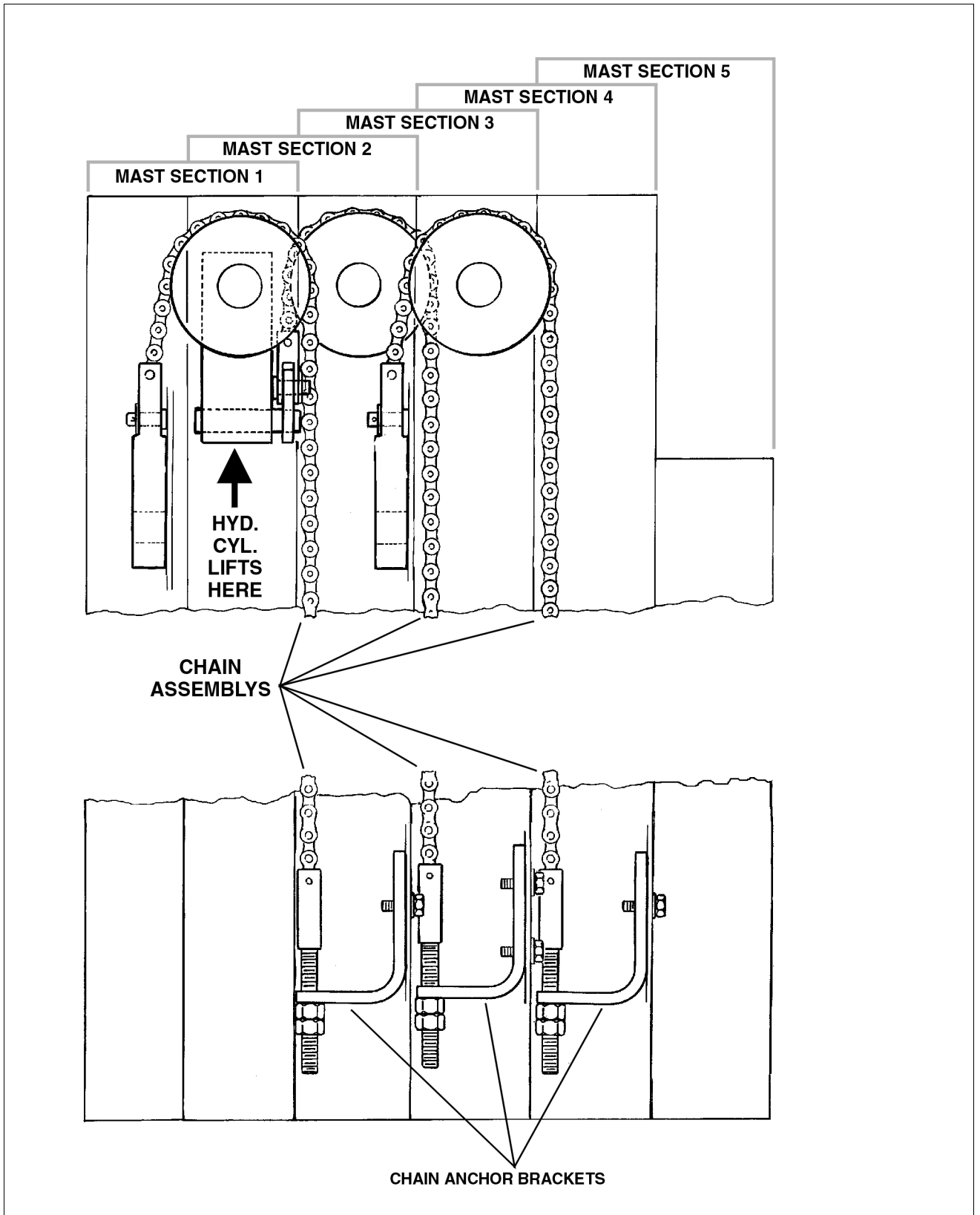

Figure 5-6. Mast Chain Routing Diagram. - DVL/DVSP

## SECTION 5 - MAST COMPONENTS

### Mast Assembly - DVL/DVSP

(See Figure 2-2.)

#### MAST SECTION 1 - ASSEMBLY

1. Place mast section-1, rail (open) side up (See Figure 2-1.) on a clean, flat surface (preferably a table or work bench capable of supporting the weight of the entire mast assembly). Slide mast out over end of work surface far enough to allow access to the chain anchor attach hole near the top of the mast.
2. Locate the two (2) single (wide) chain assemblies and attach to the large equalizer anchor plate (if not already attached). Lay out the chain/anchor plate assembly with the anchor plate end towards top of the mast. (Be certain floor surface is clean and free of any metal chips or debris which may stick to lubricated chains).
3. Insert the chain/anchor plate assembly end into the top of mast section-1 and secure using the large anchor plate attach pin, spacers, and pin keeper.

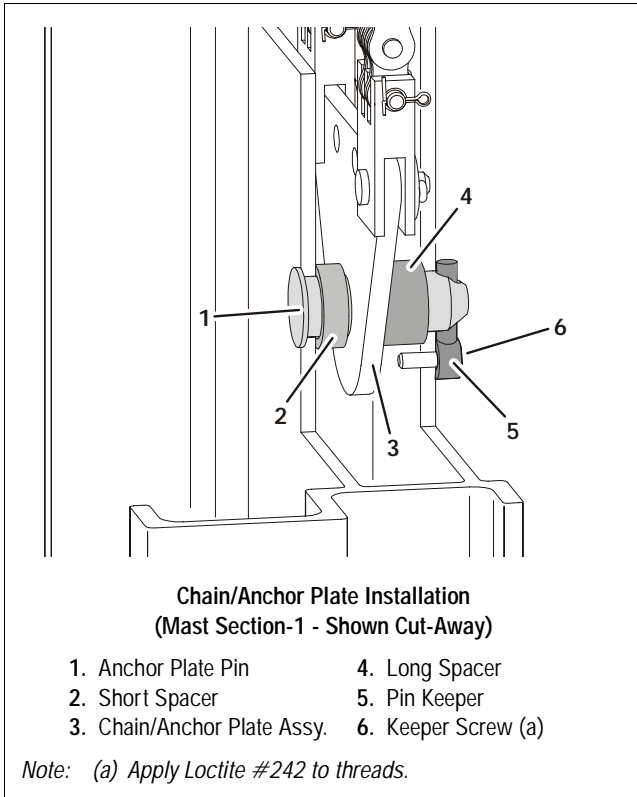

#### MAST SECTION 2 - ASSEMBLY

**NOTE:** When sliding mast sections together, be careful not to scratch or score the anodized finish in the slide pad channels.

4. Locate mast section-2, carefully slide mast section-2 closed rail into section-1 open rail. Slide sections together until ends are even.
5. Insert slide pads into the slide pad channels at bottom end of mast between section-1 and -2, (one on each side of the mast), with beveled surface facing out towards section-1.

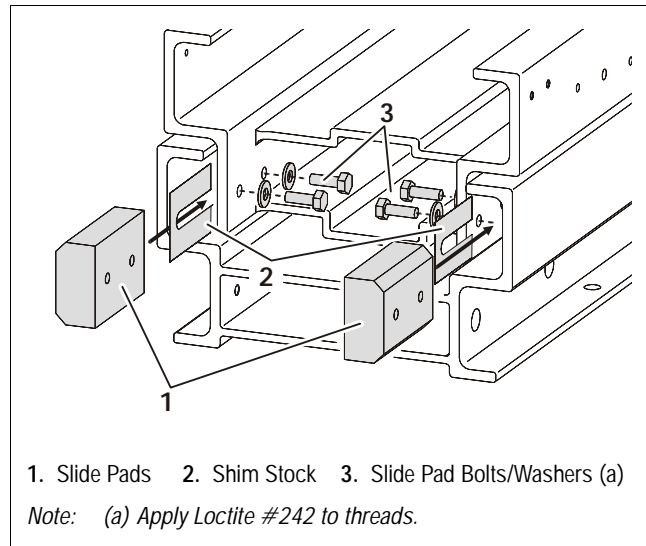

**Figure 5-7. Mast Bottom End - Slide Pad Installation (Typical)**

6. Thread slide pad attaching bolts, (two (2) 1/4"-20UNC x 3/8" long hex head bolts, place a flat washer under head of each bolt), through holes in mast section-2 inside rail, into the slide pad inserts. Thread in enough to hold pad in place.
7. Shim slide pads using the following steps:

**NOTE:** Always use the an even amount of shim material behind slide pads on both sides of the mast rails. This will keep mast sections centered in rail channels and prevent any distortion of the mast section.

- a. Start with a .036" thick shim and a .075" thick shim per side at each slide pad.
- b. Slide shims into place between slide pad and mast rail. Tighten the slide pad mounting bolts, be sure there are no air gaps between shims, shim and mast or shim and slide pad when tightened.



- c. Check mast section for side play. If play exists add .015" shims dividing the thickness equally between both sides of mast. Insert shims until the shims cannot be inserted halfway by hand with the mast pulled to the opposite side.
  - d. When mast slide pads are shimmed properly, there should be no side to side movement of slide pad in rail channel. Mast sections should be snug in channels but still be able to slide in channel by hand.
8. Insert slide pads into the slide pad channels (*top of mast*) between section-1 and -2, (*one on each side of the mast*), with beveled surface facing in towards section-2.

**NOTE:** Before fastening and shimming the slide pad on the top left side of the mast, install a sequence cable bracket against the mast under the flatwasher.

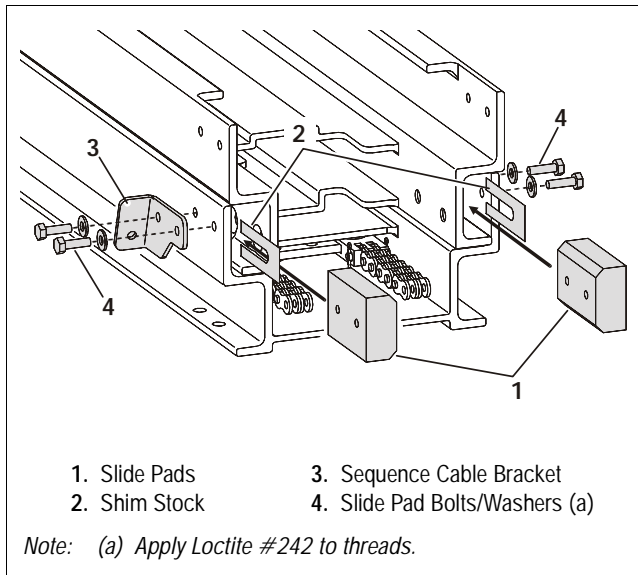

**Figure 5-8. Mast Top End - Slide Pad Installation (Typical)**

- 9. Thread slide pad attaching bolts, two (2) 1/4"-20UNC x 3/8" long hex head bolts, place a flat washer under head of each bolt, through holes in mast section-1 outside rail (*top of mast*) and into the slide pad inserts. Thread in enough to hold pad in place.
- 10. Shim per instructions in step 7, Mast Section 2 - Assembly.

- 11. Install the lift cylinder mount into the bottom of Mast Section 1.

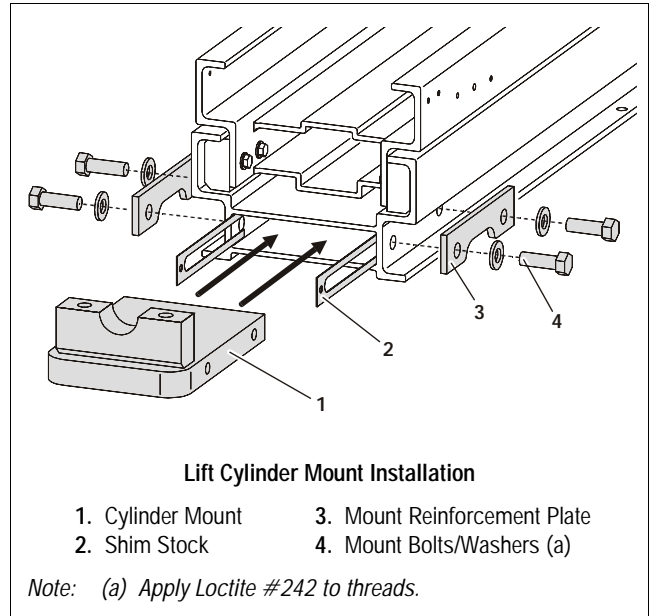

- 12. Slide the mount into mast section-1 and check for side to side clearance. Use mounting shims of equal thickness on each side to center the mount in the closed rail portion if necessary.

**NOTE:** If hydraulic cylinder needs to be extended, the protective caps on the extend and return ports will need to be temporarily removed. Be careful not to nick or scour rod surface when extending, also catch any oil draining out of cylinder to avoid spillage onto work area.

- 13. Slide mast section-2 out of mast section-1 approximately one foot.
- 14. Slide the lift cylinder into the closed rail side of mast section-2 with rod end to top and port end to bottom of mast. Cylinder should extend out of mast on both ends of the mast with the port end resting in the cylinder mount at the bottom of the mount. The manual descent valve should be pointing down towards the back of the mast assembly.
- 15. Loosely assemble the cylinder mount cap onto the lift cylinder mount to hold the cylinder assembly in place.

## SECTION 5 - MAST COMPONENTS

16. Assemble one of the narrow chains sets (#444) and to the small chain equalizer anchor plate using the pins, washers and cotter keys. Set aside.
17. Locate the chain anchor block and slide it onto the hydraulic cylinder rod end sticking out the top of mast section 2.
18. Lay out the chain(#444)/anchor plate assembly with anchor plate end towards mast, (*be certain floor surface is clean and free of any metal chip or debris which may stick to lubricated chains or lay chains in a clean bucket*).
19. Assemble the chain/anchor plate assembly and the chain anchor block to the cylinder rod end using the anchor plate/block attach pin and snap ring.

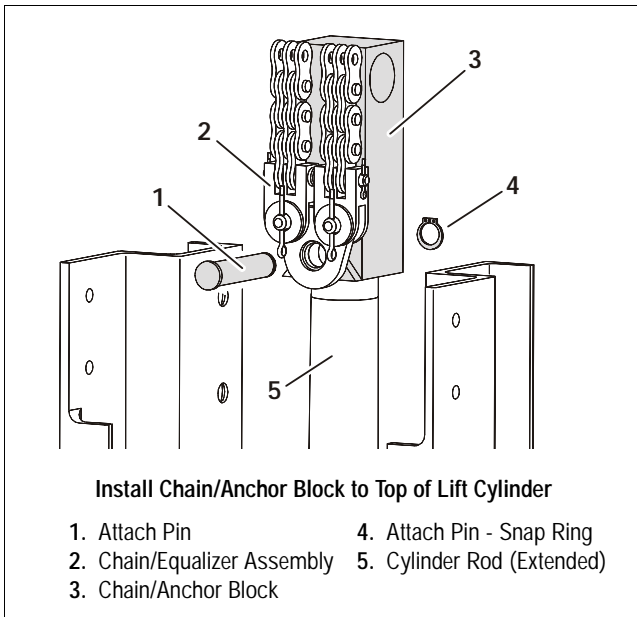

20. Assemble chain sheaves on chain assembly anchor block (*attached to cylinder rod end*) and attach to mast section-2 using following steps;
  - a. Insert sheave pin through anchor block and cylinder rod on cylinder rod end.
  - b. Load three 1" flat washers onto the sheave pin on each side of the anchor block.
  - c. Place sheave wheels (*for wide #544 chain*) on sheave pin, one each side of anchor block.
  - d. On the outside of each sheave wheel, place another 1" flatwasher, a roll pin (*into the slot in each end of the pin*), and then place a sheave pin support bar (*rectangular plate with threaded holes on each side of pin bore hole*).
  - e. Slide the whole anchor block/cylinder assembly with sheave pin, wheels and pin support bars into top of mast section-2.

- f. Align the threaded holes in the attach bars on each side of the mast and attach to top of mast section-2 using two (2) 3/8"-16UNC x 1/2" long socket head-countersunk-flathead cap screws each side. Coat threads with Loctite #171 and tighten.

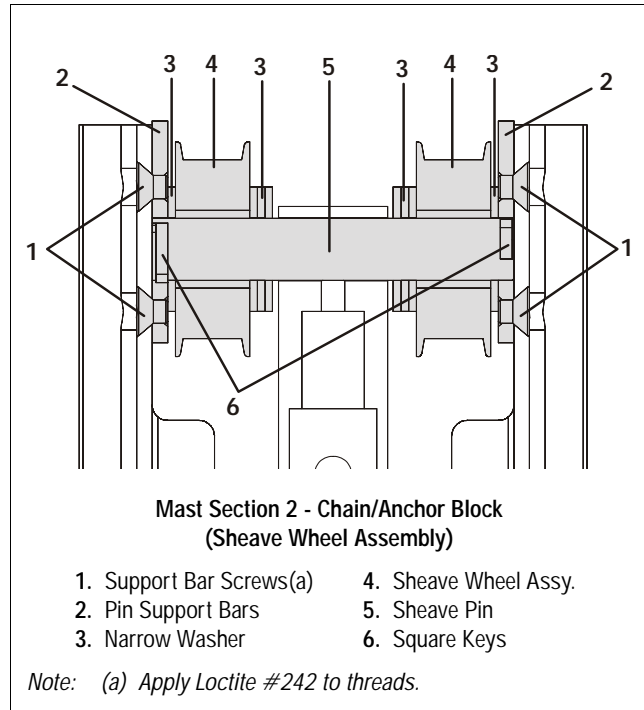

21. Remove the cylinder mount cap - shoulder screws and apply Loctite #242 to the threads. Install the screws and torque to 85 ft. lbs.
22. Tighten the center lift cylinder mount screw, this screw keeps the cylinder assembly from rotating in the mount.
23. Slide mast section-2 back into section-1 until top and bottom ends are even.

### MAST SECTION 3 - ASSEMBLY

**NOTE:** *When sliding mast sections together, be careful not to scratch or score the anodized finish in the slide pad channels.*

24. Carefully slide mast section-3 into section-2 until ends are even.
25. Insert slide pads into the top end mast rails between section-2 and -3, (*one on each side of the mast*), with beveled surface facing inward towards section-3. (*Same as Figure 5-8.*)

**NOTE:** *Before fastening and shimming the slide pad on the top left side of the mast, install a sequence cable bracket against the mast under the flatwasher.*

26. Thread slide pad attaching bolts, two (2) 1/4"-20UNC x 3/8" long hex head bolts, place a flat washer under head of each bolt, through holes in outside rail, on top of mast section-2 and into the slide pad inserts. Thread in enough to hold pad in place.
27. Shim per instructions in step 7, Mast Section 2 - Assembly.
28. Insert slide pads into the bottom end mast rails between section-2 and -3, (one on each side of the mast), with beveled surface facing out towards section-2. (Same as Figure 5-7.)
29. Thread slide pad attaching bolts, two (2) 1/4"-20UNC x 3/8" long hex head bolts, place a flat washer under head of each bolt, through holes on inside rail, on bottom end of mast section-3 and into the slide pad inserts. Thread in enough to hold pad in place.
30. Shim per instructions in step 7, Mast Section 2 - Assembly.
31. Slide section-3 out the bottom of section-2 approximately one (1) foot.
32. Locate one (1) of the chain (bottom) anchor brackets (one with threaded holes horizontally aligned to outside of bracket). Attach using outer set of holes in bottom of mast section-3 with two (2) 1/4"-20UNC x 3/4" long bolts, place a flatwasher under head of each bolt.

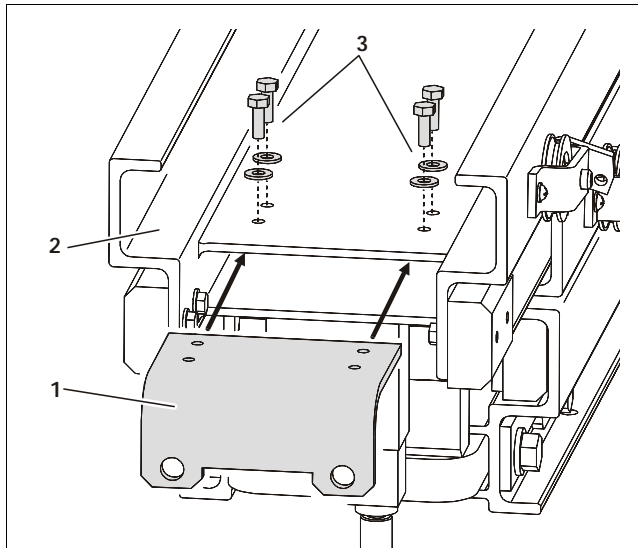

Mast Section 3 - Chain Anchor Bracket  
(Bottom of Mast)

- |                         |                             |
|-------------------------|-----------------------------|
| 1. Chain Anchor Bracket | 3. Anchor Bolts/Washers (a) |
| 2. Mast Section 3       |                             |

Note: (a) Apply Loctite #242 to threads.

33. Slide section-3 out the top of section-2 approximately one (1) foot.
34. Locate the remaining narrow chain set (#444) and attach them to the remaining triangular shaped anchor plate using the attach pins, flat washers and cotter keys.

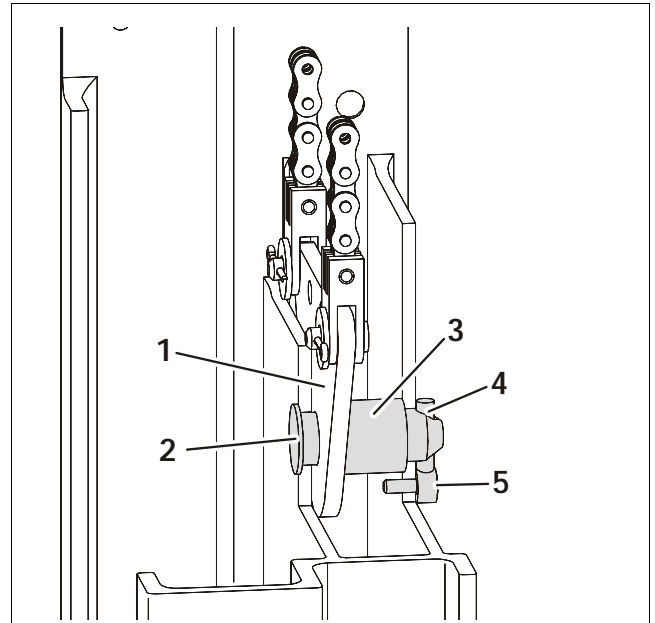

Mast Section 3 - Chain/Anchor Plate Installation  
(Mast Section-3 Shown Cut-away)

- |                             |                     |
|-----------------------------|---------------------|
| 1. Chain/Anchor Plate Assy. | 4. Pin Keeper       |
| 2. Anchor Pin               | 5. Keeper Screw (a) |
| 3. Spacer                   |                     |

Note: (a) Apply Loctite #242 to threads.

35. Install the chain/anchor plate assembly into the top of mast section-3, using the remaining large pin and pin keeper. Allow to hang out the top of mast section-3 for later assembly.
36. Insert the threaded ends of chain assembly (attached to top of mast section-1), into the opening between mast section-2 and mast section-3. Slide the threaded ends through the holes in chain anchor bracket attached at the bottom of mast section-3. Loosely thread two (2) 3/8"-16UNC nuts onto stud threads on each chain and remove any slack in the chains. Chains will be adjusted later in assembly.

## SECTION 5 - MAST COMPONENTS

37. Assemble chain sheaves (*for narrow chain assembly*) to top of mast section-3 as follows;
- Place four (4) of the 1" flat washers onto one of the remaining sheave pins. Locate two (2) narrow chain sheave wheels and slide onto sheave pin on each side of the flat washers.
  - Slide two (2) short spacer tubes onto sheave pin, one each end of sheave pin to outside of sheave wheels.
  - Place two (2) sheave pin support bars, one each end of sheave pin onto outside of spacer tubes. Place a roll pin in the slots at each end of the sheave pins and align with the cutouts in the pin support bars.
  - Holding complete sheave wheel assembly, slide assembly into top of mast section-3 and align threaded holes in sheave pin support bars with holes in mast rails.
  - Attach to top of mast section-3 using two (2) 3/8"-16UNC x 1/2" long socket head-countersunk-flathead cap screws, each side. Coat threads with Loctite #171 and tighten.

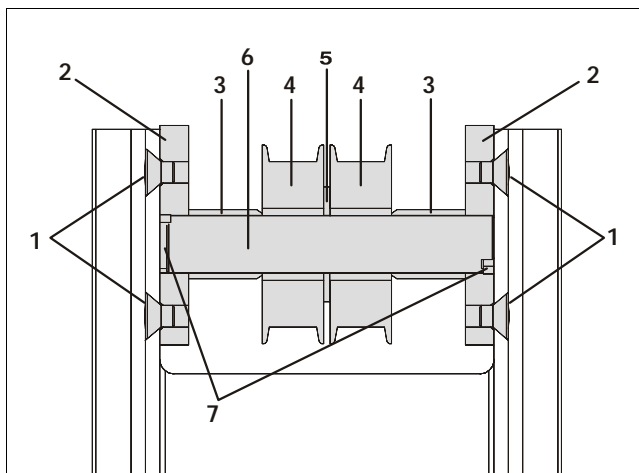

**Mast Section 3 - Sheave Wheel Assembly**

- |                           |                  |
|---------------------------|------------------|
| 1. Support Bar Screws (a) | 5. Narrow Washer |
| 2. Pin Support Bars       | 6. Sheave Pin    |
| 3. Wide Spacers           | 7. Square Keys   |
| 4. Sheave Wheel Assys.    |                  |

Note: (a) Apply Loctite #242 to threads.

38. Slide mast section-3 back into section-2 until ends are even. Check to make sure chain assembly (*wide chains*) are seating properly in chain anchor block chain sheave wheels attached to mast section-2.

### MAST SECTION 4 - ASSEMBLY

**NOTE:** When sliding mast sections together, be careful not to scratch or score the anodized finish in the slide pad channels.

- Carefully slide mast section-4 into section-3 until ends are even.
- Insert slide pads into the top end mast rails between section-2 and -3, (*one on each side of the mast*), with beveled surface facing inward towards section-3. (*Same as Figure 5-8.*)

**NOTE:** Before fastening and shimming the slide pad on the top left side of the mast, install a sequence cable bracket against the mast under the flatwasher.

- Thread slide pad attaching bolts, two (2) 1/4"-20UNC x 3/8" long hex head bolts, place a flat washer under head of each bolt, through holes in outside rail, on top of mast section-2 and into the slide pad inserts. Thread in enough to hold pad in place.
- Shim per instructions in step 7, Mast Section 2 - Assembly.
- Insert slide pads into the bottom end mast rails between section-2 and -3, (*one on each side of the mast*), with beveled surface facing out towards section-2. (*Same as Figure 5-7.*)
- Thread slide pad attaching bolts, two (2) 1/4"-20UNC x 3/8" long hex head bolts, place a flat washer under head of each bolt, through holes on inside rail, on bottom end of mast section-3 and into the slide pad inserts. Thread in enough to hold pad in place.
- Shim per instructions in step 7, Mast Section 2 - Assembly.
- Slide section-4 out the bottom of section-3 approximately one (1) foot.
- Locate one (1) of the chain bottom anchor plates (*one with threaded holes horizontally aligned to center of bracket*). Attach using holes in bottom of mast section-4 with three (3) 1/4"-20UNC x 3/4" long bolts, place a flatwasher under head of each bolt.

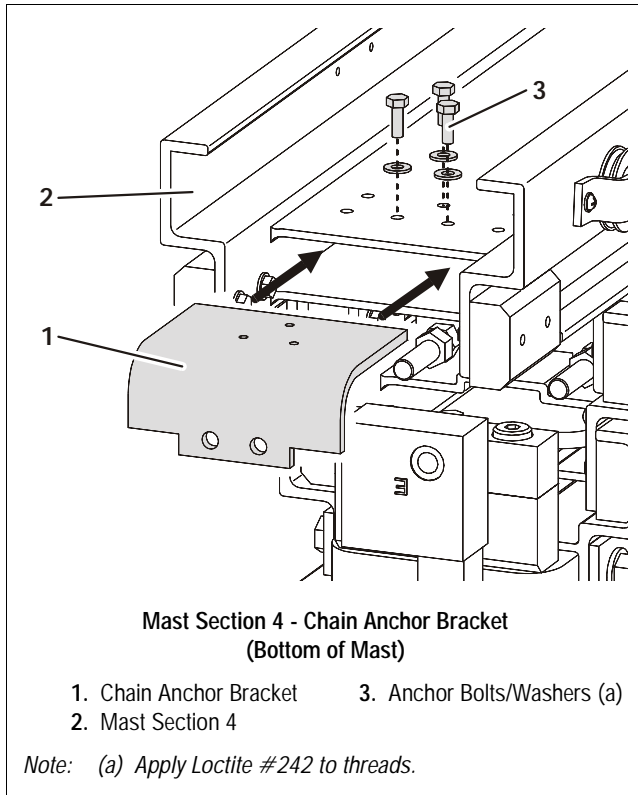

48. Slide section-4 out the top of section-3 approximately one (1) foot.
49. Insert threaded ends of chain assembly (*attached to top of mast section-2*), into the opening between mast section-3 and mast section-4. Slide the threaded ends through the holes in bottom anchor plate attached to bottom of mast section-4. Loosely thread two (2) 3/8"-16UNC nuts onto stud threads on each chain until all slack is taken out of chain. Chains will be adjusted later in assembly.

50. Assemble chain sheaves (*for narrow chain assembly*) to top of mast section-4 as follows:
  - a. Locate the remaining sheave pin and slide the wide tube spacer onto the pin shaft.
  - b. Place two (2) of the narrow chain sheave wheels onto the sheave pin on each side of the wide spacer.
  - c. Slide two (2) 1" flat washers onto each end of sheave pin to outside of sheave wheels.
  - d. Place two (2) sheave pin support bars, one each end of sheave pin to outside of space tubes. Place a roll pin in the slots at each end of the sheave pins and align with the cutouts in the pin support bars.
  - e. Holding complete sheave wheel assembly, slide assembly into top of mast section-4 and align threaded holes in sheave pin support bars with holes in mast rails.
  - f. Attach to top of mast section-4 using two (2) 3/8"-16UNC x 1/2" long socket head-countersunk-flathead cap screws, each side. Coat threads with Loctite #171 and tighten.

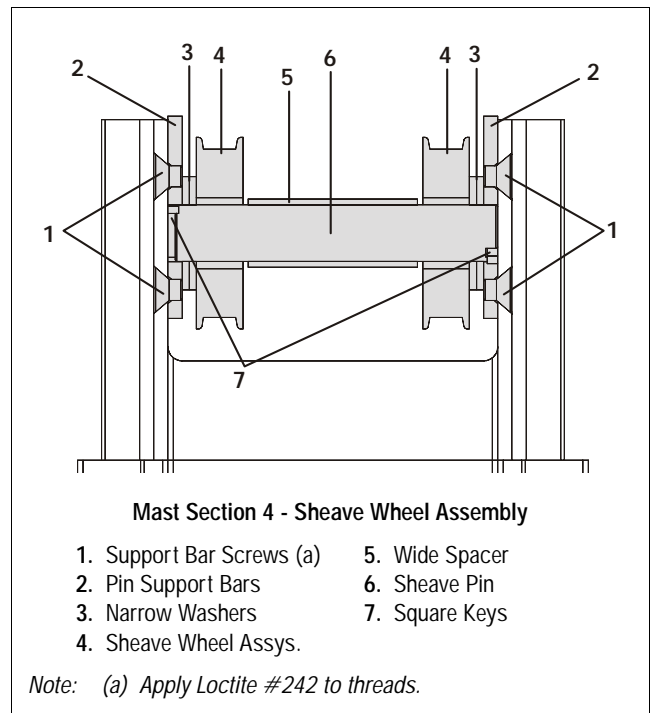

51. Carefully slide mast section-4 into section-3 until ends are even. Check to make sure chain assembly (*narrow chains*) are seating properly in chain anchor block chain sheave wheels attached to mast section-3.

## SECTION 5 - MAST COMPONENTS

### MAST SECTION 5 - ASSEMBLY

1. Locate the remaining mast section-5 (*platform mounting - mast section*). Lay mast section on flat stable surface.
2. Attach the remaining chain bottom anchor plate (*one with threaded holes aligned at the outside of bracket*). Attach through set of holes in bottom of mast section-5 with four (4) 1/4"-20UNC x 3/4" long bolts, place a flatwasher under head of each bolt.

**NOTE:** The platform mounting section slide pads, are assembled differently than the slide pads for the other mast sections. Mast section-5 slide pads may need to be assembled/disassembled several times in order to determine the correct shim stock required for proper fit.

3. Complete the following steps to determine shim stock thickness required for section-5;

**NOTE:** Always use the an even amount of shim material behind slide pads on both sides of the mast rails. This will keep mast sections centered in rail channels and prevent any distortion of the section.

- a. Use two shim pieces per slide pad, a thick one and a thin one.
- b. Start with a total thickness of approximately .035" and .075" thick shim stock.

- c. Attach shim stock and slide pads to both sides of mast section-5 using five (5) 1/4"-20UNC x 1-1/4" long, hex head cap screws per side, with flatwasher under each bolt head. (*Assemble shim stock and slide pad to mast section rail with shim stock against rail and slide pad with beveled side out*).
- d. Carefully thread the slide pad mounting bolts with flat washers through slide pads and shim stock into threads in mast section-5. Be certain there are no air gaps between shims, shim and mast or shim and slide pad when tightened.

**NOTE:** Mast section-5 into section-4 fit should be very snug but still be able to be pushed together by hand. If too tight, remove section-5, disassemble slide pad and reduce thickness of shim stock.

- e. Begin sliding top of mast section-5 with closed rail down engaging the slide pads into slide pad channels at bottom of mast section-4's open rail. Continue to push section-5 into section-4 until BOTTOM ends of mast sections are even.
- f. Check mast section for side play. If play exists use thicker shims dividing thickness equally between both sides of mast.
- g. When mast slide pads are shimmed properly, there should be no side to side movement of slide pad in rail channel. Mast sections should be very snug in channels but still be able to slide in channel by hand.

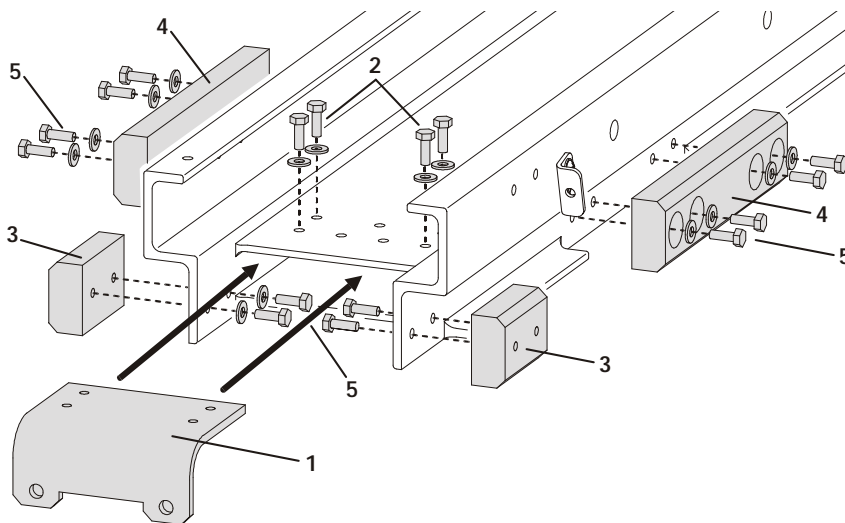

Mast Section 5 - Bottom End Components  
(Chain Anchor Bracket and Slide Pad Installation)

- |                                    |                   |                                |
|------------------------------------|-------------------|--------------------------------|
| 1. Chain Anchor Bracket            | 3. Slide Pad      | 5. Slide Pad Bolts/Washers (a) |
| 2. Anchor Bracket Bolts/Washers(a) | 4. Long Slide Pad |                                |

Note: (a) Apply Loctite #242 to threads.

4. Slide mast section-5 out even with top of section-4.
5. Insert threaded ends of chain assembly (*attached to top of mast section-3*) into the opening between mast section-4 and mast section-5. Slide the threaded ends through the holes in bottom chain anchor plate located on bottom of mast section-5. Loosely thread two (2) 3/8"-16UNC nuts onto stud threads on each chain. Chains will be adjusted later in assembly.
6. Slide mast section-5 back into mast section-4 until bottom ends of masts are even. Check to make sure chain set attached to top of section-3 is seating properly in cable sheave wheels attached to top of mast section-4. (*Mast section-3 may need to be restrained to keep it's slide pads from pushing out the bottom of mast sections-2*).
7. At bottom of mast assembly, thread all chain adjusting nuts on threaded ends until they are snug against the bottom anchor plates and all slack is removed from chains. Check that chains are seated in their sheave wheels at top of mast assembly.
8. Do not assemble the mini covers to the top of mast sections until the mast chains have been adjusted properly.
9. Attach the lanyard attach assembly to the side of mast section 5.
10. Attach the sequencing cables and hardware to the sides of the mast assembly.
11. Install the mast chain guard to the top mast section 5.

The mast assembly is now ready to install on the machines base frame.

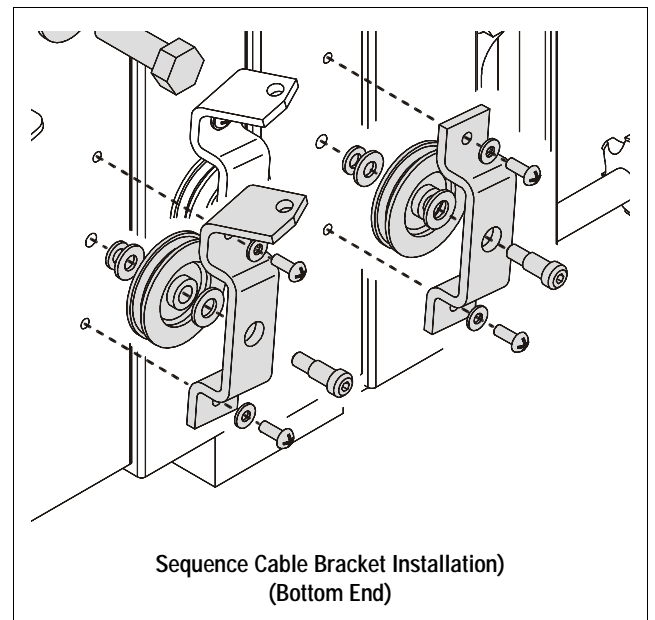
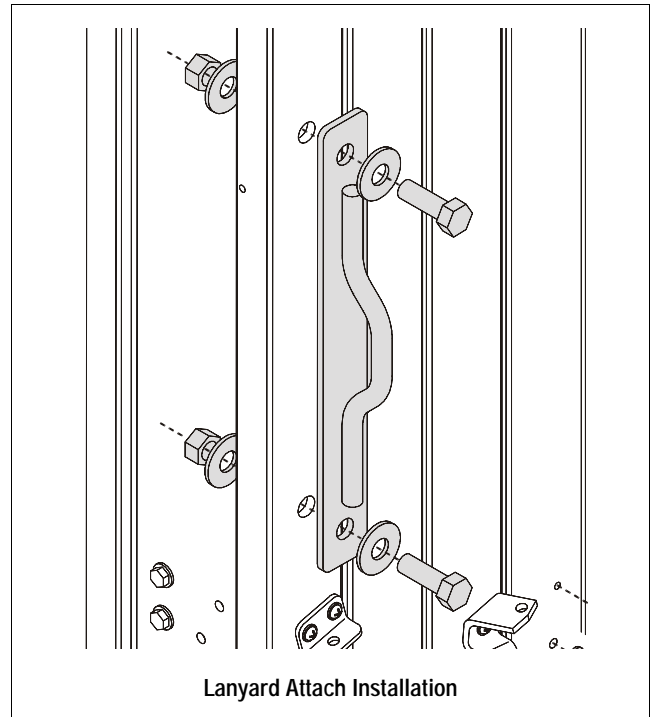

5.7 DVSP - STOCKPICKER PLATFORM -  
INSTALLATION

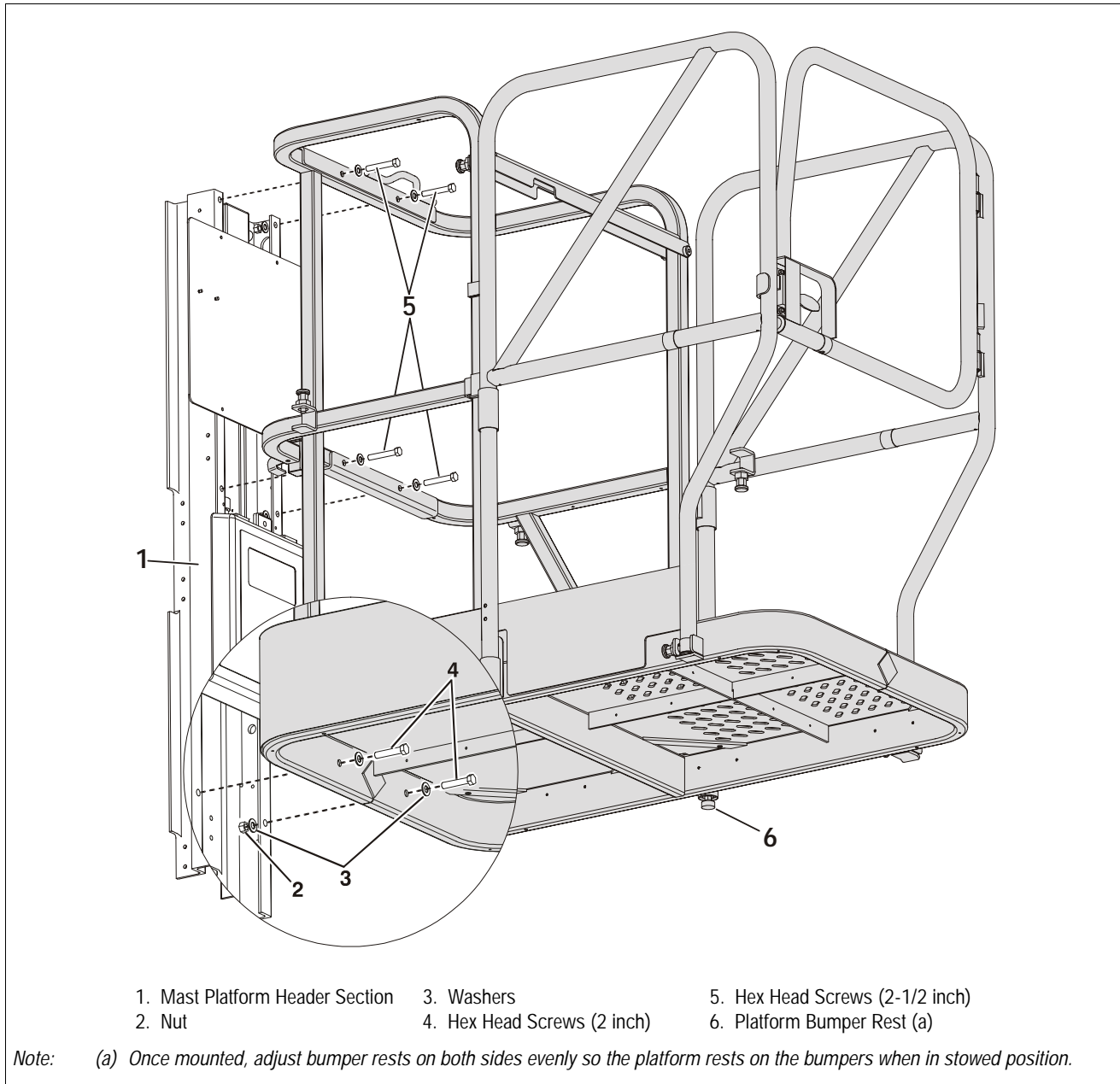
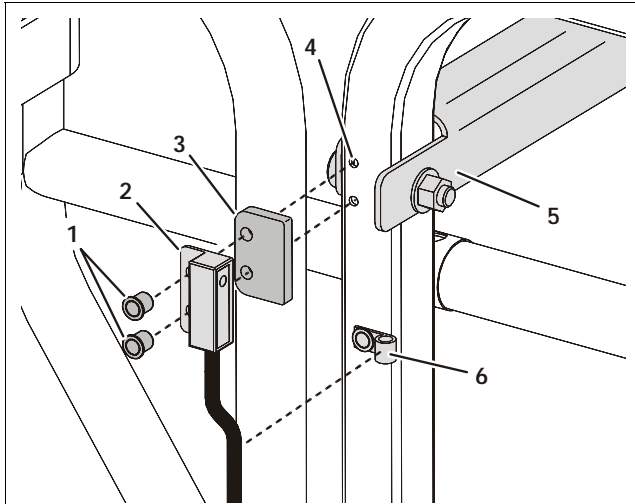

Figure 5-9. DVSP - StockPicker Platform Installation.



**5.8 DVSP - STOCKPICKER PLATFORM - MID-GATE INTERLOCK INSTALLATION**



**DVSP - Platform - Mid-Gate Interlock Switch Installation**

- |                     |                       |
|---------------------|-----------------------|
| 1. Pop Rivets       | 4. Mounting Holes     |
| 2. Interlock Switch | 5. Mid-Gate           |
| 3. Spacer           | 6. Wire Harness Clamp |

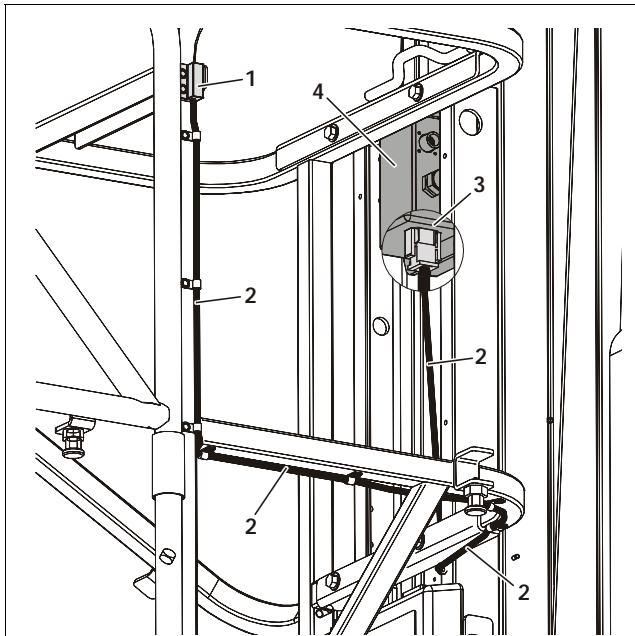

**DVSP - Platform - Mid-Gate Interlock Switch  
Wiring Harness Routing**

- |                     |                               |
|---------------------|-------------------------------|
| 1. Interlock Switch | 3. Connection at Junction Box |
| 2. Wire Routing     | 4. Platform Junction Box      |

Notes: Decal billboard removed in above illustration.

**5.9 MAST BEACON - INSTALLATION**

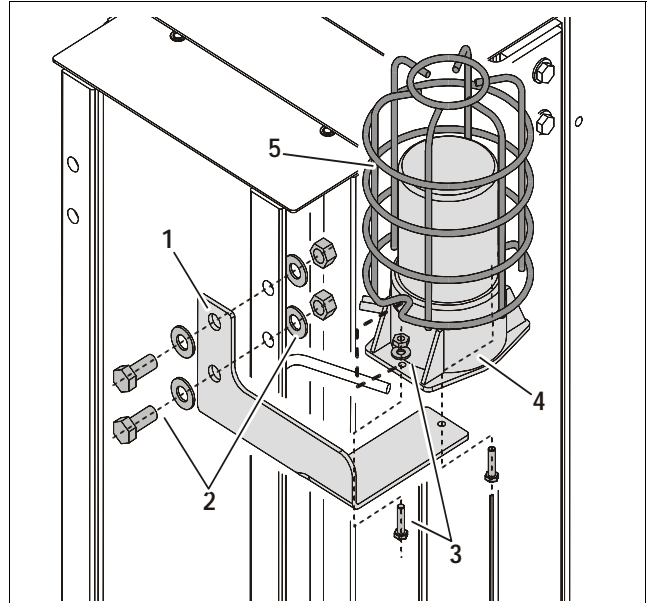

**Mast Mounted Beacon Installation (DVL/DVSP)**

- |                                |                     |
|--------------------------------|---------------------|
| 1. Beacon Mounting Bracket     | 4. Beacon Assembly  |
| 2. Bracket Screws/Nuts/Washers | 5. Beacon Guard (a) |
| 3. Beacon Screws/Nuts/Washers  |                     |

Notes: (a) Guard on UL-EE specification machines only.

**This page intentionally left blank.**

---

## SECTION 6. TROUBLESHOOTING

---

### 6.1 GENERAL

This section contains troubleshooting information to be used for locating and correcting most operating problems. If a problem should develop which is not presented in this section or which is not corrected by listed corrective actions, technically qualified guidance should be obtained before proceeding with any maintenance.

---

### 6.2 TROUBLESHOOTING INFORMATION

Troubleshooting procedures applicable to this machine are listed and defined starting with Section 6.5, TROUBLESHOOTING TABLES Index in this section of the manual.

Each malfunction within an individual group or system is followed by a listing of probable causes which will enable determination of the applicable remedial action. The probable causes and the remedial action should, where possible, be checked in the order listed in the troubleshooting tables.

It should be noted that there is no substitute for a thorough knowledge of the equipment and related systems.

It should be recognized that the majority of the problems arising in the machine will be centered in the hydraulic and electrical systems. For this reason, every effort has been made to ensure that all likely problems in these areas are given the fullest possible treatment. In the remaining machine groups, only those problems which are symptomatic of greater problems which have more than one probable cause and remedy are included. This means that problems for which the probable cause and remedy may be immediately obvious are not listed in this section.

The first rule for troubleshooting any circuit that is hydraulically operated and electrically controlled is to determine if the circuit is lacking hydraulic oil and electrical control power. This can be ascertained by overriding the bypass valve (*mechanically or electrically*) so that oil is available to the function valve, then overriding the function valve mechanically. If the function performs satisfactorily, the problem exists with the control circuit.

---

### 6.3 HYDRAULIC CIRCUIT CHECKS

(See Figure 6-5.)

The first reference for improper function of a hydraulic system, where the cause is not immediately apparent, should be the Hydraulic Diagram Circuit. The best place to begin the problem analysis is at the power source (*pump*). Once it is determined that the pump is serviceable, then a systematic check of the circuit components, would follow.

**NOTE:** For aid in troubleshooting, refer to Figure 6-5. for HYDRAULIC DIAGRAM circuit.

---

### 6.4 ELECTRICAL CIRCUIT CHECKS

#### General

---

The drive system on the DVL Series and DVSP machines requires a microprocessor controlled electrical circuit to operate smoothly and accurately. All platform control console functions are relayed to various machine components (*i.e. platform up/down, drive functions, etc.*) through the Ground Control Module microprocessor box (*mounted at the rear of the machine*). The Ground Control Module is pre-programmed with factory pre-set personality settings for each machine function.

To help diagnose any problems with components plugged into the Ground Control Module, the module is designed with an internal fault code and text messaging system displayed on an LCD screen at the module. The platform control console also will display LED Flash Codes using the LED strip at the top of the console. When operating normally the LED panel on the platform control console indicates the battery voltage status using ten (10) LEDs (*red/yellow/green*). If a malfunction to the machine's electrical components occurs, the platform console LED's will flash a number of LEDs to help indicate the problem to the Operator in the platform. The Fault Codes and LED Flash Codes are outlined in the following sub-sections of this chapter.

**NOTE:** For aid in troubleshooting electrical problem, refer to Figure 6-3. for an ELECTRICAL DIAGRAM of the various circuits. Also for a pictorial overview of the connected components, See Figure 6-2. "Pictorial Overview of the DVL/DVSP Electrical System".

Ground Control Module LCD Display

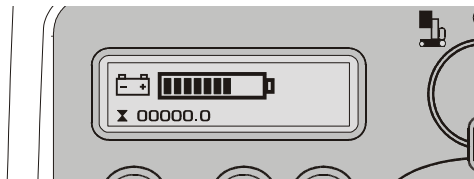

At power-up and during operation the LCD display on the Ground Control Module displays the current machine operating status. The following illustration explains the symbol indications.

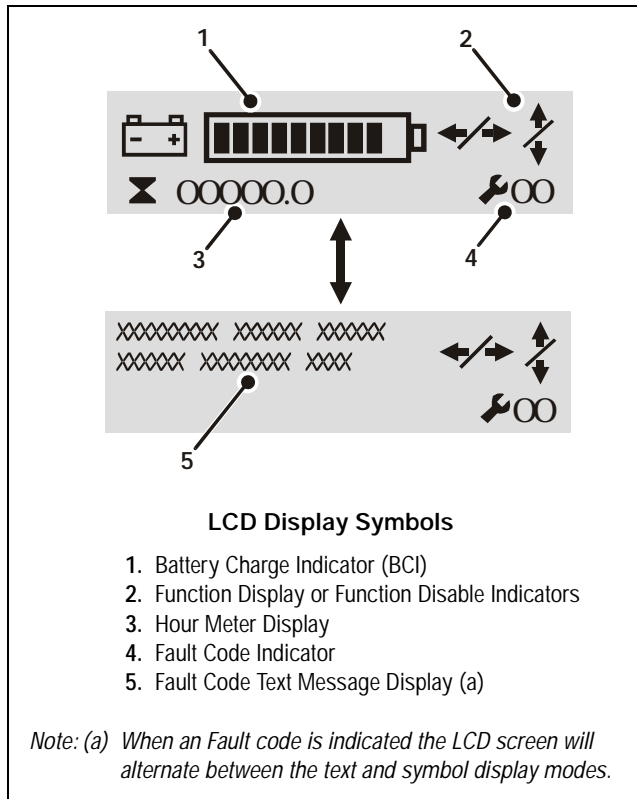

In the LCD Display Symbols illustration item (2) above, the Function Display or Function Disable Indicators will vary as shown following:

	DRIVE Disabled		Both LIFT UP and LIFT DOWN Disabled
	LIFT UP Disabled		Drive Speed Cut-Back (Turtle) Mode Engaged
	LIFT DOWN Disabled		Battery Charger Plugged In

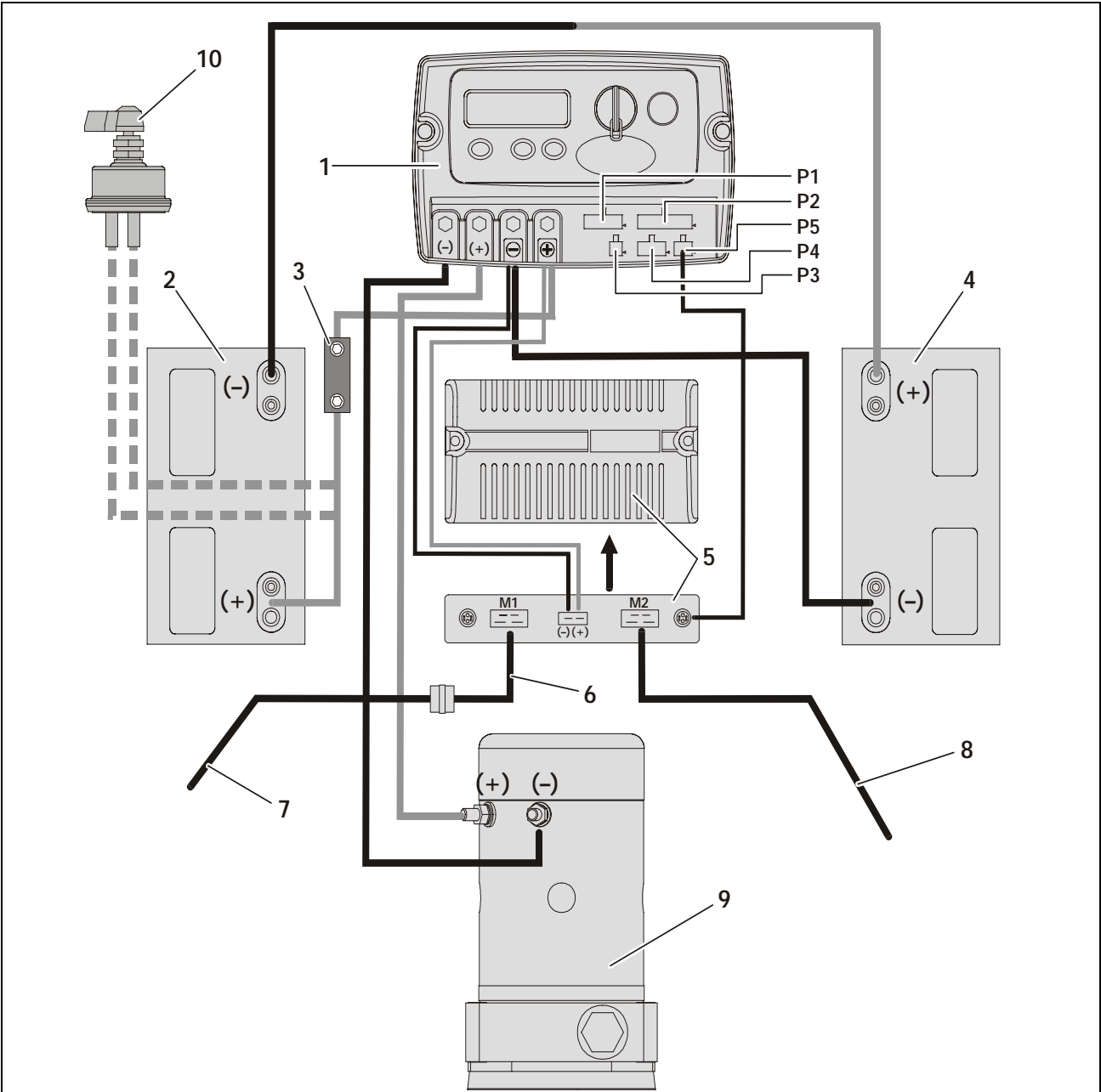

- |                              |   |                                  |
|------------------------------|---|----------------------------------|
| 1. Ground Control Module (a) | 5. Traction Control Module (a)                | 9. Pump/Motor/Tank Assembly (b)  |
| 2. Left Side Battery (b)     | 6. Left Drive Motor Harness Reverser (a)      | 10. Master Disconnect Switch (c) |
| 3. 175 Amp Fuse              | 7. Power Cable To Left Drive Motor/Brake (a)  |                                  |
| 4. Right Side Battery (b)    | 8. Power Cable To Right Drive Motor/Brake (a) |                                  |

Ground Control Module Plugs: P1 - Horn, Alarm, Beacons, Lift Down Valve Harness (a) P4 - Platform Junction Box Harness (a)  
 P2 - PHP, Elevation/Speed, Charger Limit Switch Harness (a) P5 - Joystick Protocol Harness (a)  
 P3 - Programmable Security Lock Harness (Option) (a)

Notes: (a) Apply di-electric grease JLG Part Number 3020038 to wiring harness terminals, to prevent moisture from entering module.  
 (b) Seal NEG (-) and POS (+) posts with battery grease to prevent corrosion.  
 (c) Machines equipped with the UL-EE specification (option) only.

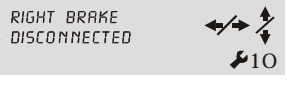

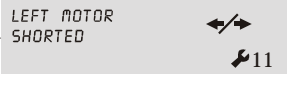

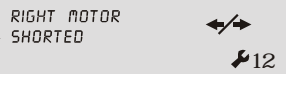







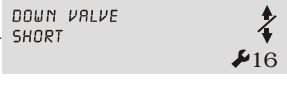

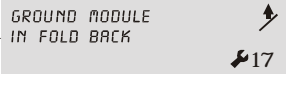

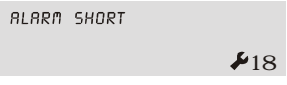



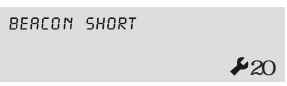



Figure 6-1. Component Electrical Connections.

## SECTION 6 - TROUBLESHOOTING

Table 6-1. LCD Display - Service Fault Code Conditions

FAULT CODE	PLATFORM CONSOLE LEDs FLASHING	LCD SYMBOL SCREEN	LCD TEXT SCREEN	FAULT DESCRIPTION/ MACHINE CONDITION	TROUBLESHOOTING
—	—		—	Machine In Drive Speed Cut-Back (Turtle) Mode All The Time	See Table 6-5, Page 6-11
—	—		BRAKES RELEASED	Brakes Released DRIVE Disabled	Engage Brakes - Press Brake Release Button on Ground Control Station
—	—		—	Charger AC Plugged In DRIVE Disabled	Unplug Charger AC Input Power Cord from Machine
—	—		OBSTRUCTION BELOW PLATFORM	Obstruction Sensor System (Platform Elevated) LIFT DOWN Disabled	See Table 6-6, Page 6-12
—	—		ENTER SECURITY CODE	Programmable Security Lock Password	Type in Code At PSL Key Pad See Operators Manual for Proper Operation
—	1		LOW BATTERY	Low Battery Voltage	See Page 6-12
02	2		LEFT PHP BAR UP	Left PHP Bar UP (Platform Elevated) DRIVE and Lift UP Disabled	See Table 6-7, Page 6-13
03	2		RIGHT PHP BAR UP	Right PHP Bar UP (Platform Elevated) DRIVE and Lift UP Disabled	See Table 6-8, Page 6-13
04	3		TILTED	Tilt Condition (Platform Elevated) DRIVE and Lift UP Disabled	See Table 6-9, Page 6-14
05	—	RESERVED		RESERVED	
06	—	RESERVED		RESERVED	
07	6		LEFT MOTOR DISCONNECTED	Left Drive Motor Disconnected DRIVE Disabled	See Table 6-10, Page 6-14
08	6		RIGHT MOTOR DISCONNECTED	Right Drive Motor Disconnected DRIVE Disabled	See Table 6-11, Page 6-15
09	6		LEFT BRAKE DISCONNECTED	Left Brake Disconnected DRIVE, Lift UP/DOWN Disabled	See Table 6-12, Page 6-15

Table 6-1. LCD Display - Service Fault Code Conditions

FAULT CODE	PLATFORM CONSOLE LEDs FLASHING	LCD SYMBOL SCREEN	LCD TEXT SCREEN	FAULT DESCRIPTION/MACHINE CONDITION	FOR TROUBLESHOOTING REFER TO
10	6			Right Brake Disconnected DRIVE, Lift UP/DOWN Disabled	See Table 6-13, Page 6-15
11	6			Left Drive Motor Short Circuit DRIVE Disabled	See Table 6-14, Page 6-16
12	6			Right Drive Motor Short Circuit DRIVE Disabled	See Table 6-15, Page 6-16
13	6			Traction Module In Fold Back DRIVE Disabled	See Table 6-16, Page 6-16
14	7			Pump Motor Disconnected Lift UP Disabled	See Table 6-17, Page 6-17
15	7			Lift Down Valve Disconnected Lift UP/DOWN Disabled	See Table 6-18, Page 6-17
16	7			Down Valve or Down Valve Circuit Short Lift UP/DOWN Disabled	See Table 6-19, Page 6-18
17	7			Ground Control Module In Fold Back (Machine Stopped)	See Table 6-20, Page 6-18
18	—			Alarm or Alarm Circuit Short	See Table 6-21, Page 6-18
19	—			Alarm Disconnected	See Table 6-22, Page 6-19
20	—			Beacon or Beacon Circuit Short	See Table 6-23, Page 6-19
21	—			Beacon Disconnected	See Table 6-24, Page 6-20
22	—			Horn or Horn Circuit Short	See Table 6-25, Page 6-20

## SECTION 6 - TROUBLESHOOTING

Table 6-1. LCD Display - Service Fault Code Conditions











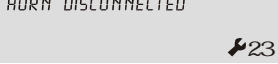

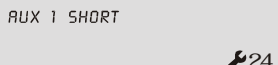





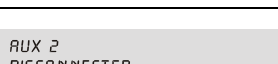





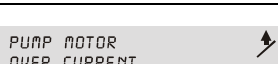

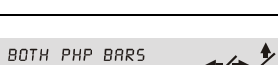
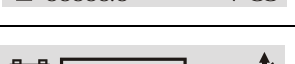

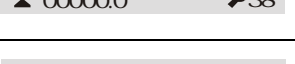
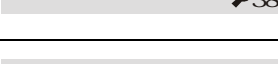
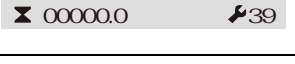

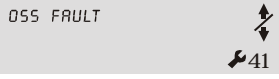

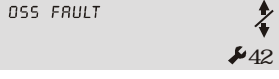

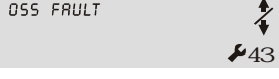



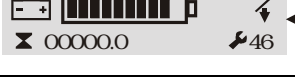

FAULT CODE	PLATFORM CONSOLE LEDs FLASHING	LCD SYMBOL SCREEN	LCD TEXT SCREEN	FAULT DESCRIPTION/MACHINE CONDITION	FOR TROUBLESHOOTING REFER TO
23	—			Horn Disconnected	See Table 6-26, Page 6-21
24	—			Auxiliary #1 Circuit Short	See Table 6-27, Page 6-21
25	—			Auxiliary #1 Circuit Disconnected	See Table 6-28, Page 6-22
26	—			Auxiliary #2 Circuit Short	See Table 6-29, Page 6-22
27	—			Auxiliary #2 Circuit Disconnected	See Table 6-30, Page 6-23
28	—	RESERVED		RESERVED	
29	—	RESERVED		RESERVED	
30	6			Traction Module No Communication with Ground Control Module	See Table 6-31, Page 6-24
31	—			Platform Control Console No Communication with Ground Control Module	See Table 6-32, Page 6-25
32	7			Pump Motor Over Current LIFT UP Disabled	See Table 6-33, Page 6-25
33	2			Both PHP Bars UP DRIVE and Lift UP Disabled	See Table 6-34, Page 6-26
38	2			2 LEDs/BARS Flashing with an audible beep. Platform Lift-UP Function is Locked Out.	See Page 6-26
39	1			1 LED/BAR Flashing with an audible beep. Drive and Platform Lift-UP Functions Locked Out.	See Page 6-26
40	5			Obstruction Sensor System No Communication With Ground Control Station	See Table 6-35, Page 6-27

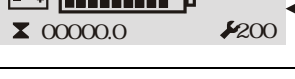

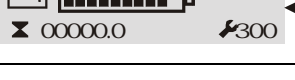
Table 6-1. LCD Display - Service Fault Code Conditions

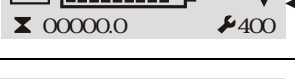
FAULT CODE	PLATFORM CONSOLE LEDs FLASHING	LCD SYMBOL SCREEN	LCD TEXT SCREEN	FAULT DESCRIPTION/MACHINE CONDITION	FOR TROUBLESHOOTING REFER TO
41	—			Internal OSS Sensor #1 Fault Condition	See Table 6-36, Page 6-28
42	—			Internal OSS Sensor #2 Fault Condition	See Table 6-36, Page 6-28
43	—			Internal OSS Sensor #3 Fault Condition	See Table 6-36, Page 6-28
44	—			Internal OSS Sensor #4 Fault Condition	See Table 6-36, Page 6-28
45	—			Internal OSS Sensor #5 Fault Condition	See Table 6-36, Page 6-28
46	—			Internal OSS Sensor #6 Fault Condition	See Table 6-36, Page 6-28
100	10			Ground Control Module Fault Condition	See Table 6-37, Page 6-29
200	10			Platform Control Console Fault Condition	See Table 6-38, Page 6-30
300	10			Traction Control Module Fault Condition	See Table 6-39, Page 6-31
400	—			OSS Control Module Low Internal Supply	See Table 6-35, Page 6-27
401	—			OSS Control Module Amplifier Fault	See Table 6-35, Page 6-27

**6.5 TROUBLESHOOTING TABLES INDEX**

---

**SPECIFICATIONS FOR VARIOUS COMPONENTS PAGE**

---

Ohm Ratings for Various Components . . . . . 6-10  
Amperage Draw for Various Components . . . . . 6-10

---

**SPECIAL PIN EXTRACTOR TOOLS FOR ELECTRICAL CONNECTORS**

---

Special Pin Extractor Tools for Electrical Connectors . . . . . 6-10

---

**FAULT CODE TROUBLESHOOTING TABLES**

---

Machine in Drive Speed Cut-Back (Turtle) Mode All The Time . . . . . 6-11  
Obstruction Sensor System - Detection . . . . . 6-12  
Battery Voltage Low - Warning Level 3 - Three (3) LED/LCDs lit . . . . . 6-12  
Code 02 - Left PHP Bar - UP . . . . . 6-13  
Code 03 - Right PHP Bar - UP . . . . . 6-13  
Code 04 - Tilt Condition . . . . . 6-14  
Code 05 - Reserved . . . . . 6-14  
Code 06 - Reserved . . . . . 6-14  
Code 07- Left Drive Motor - Disconnected . . . . . 6-14  
Code 08 - Right Drive Motor - Disconnected . . . . . 6-15  
Code 09 - Left Brake - Disconnected . . . . . 6-15  
Code 10 - Right Brake - Disconnected . . . . . 6-15  
Code 11 - Left Drive Motor - Short Circuit . . . . . 6-16  
Code 12 - Right Drive Motor - Short Circuit . . . . . 6-16  
Code 13 - Traction Module - In Fold Back . . . . . 6-16  
Code 14 - Pump Motor - Disconnected . . . . . 6-17  
Code 15 - Lift Down Valve - Disconnected . . . . . 6-17  
Code 16 - Lift Down Valve - Short Circuit . . . . . 6-18  
Code 17 - Ground Control Module - In Fold Back . . . . . 6-18  
Code 18 - Alarm - Short Circuit . . . . . 6-18  
Code 19 - Alarm - Disconnected . . . . . 6-19  
Code 20 - Beacon - Short Circuit . . . . . 6-19  
Code 21 - Beacon - Disconnected . . . . . 6-20  
Code 22 - Horn - Short Circuit . . . . . 6-20  
Code 23 - Horn - Disconnected . . . . . 6-21  
Code 24 - Auxiliary #1 Circuit - Short Circuit . . . . . 6-21  
Code 25 - Auxiliary #1 Circuit - Disconnected . . . . . 6-22  
Code 26 - Auxiliary #2 - Short Circuit . . . . . 6-22  
Code 27 - Auxiliary #2 - Disconnected . . . . . 6-23  
Code 28 - Reserved . . . . . 6-23  
Code 29 - Reserved . . . . . 6-23  
Code 30 - Traction Module - No Communication with Ground Control Module . . . . . 6-24  
Code 31 - Platform Control Console - No Communication with Ground Control Module . . . . . 6-25  
Code 33 - Both PHP Bars - UP . . . . . 6-26  
Code 38 - Battery Voltage Low - Warning Level 2 - Two (2) LED/LCDs lit . . . . . 6-26

Code 39 - Battery Voltage Low - Warning Level 3 - One (1) LED/LCDs lit . . . . .	6-26
Code 40 - Obstruction Sensor System - No Communication with Ground Control Module . .	6-27
Codes 41 thru 46 - OSS - Sensor 1 through 6 - Fault Condition. . . . .	6-28
Codes (100 - 199) Ground Control Module - Fault Condition . . . . .	6-29
Codes (200 - 299) Platform Control Console - Fault Condition. . . . .	6-30
Codes (300 - 399) Traction Control Module - Fault Condition. . . . .	6-31

**MAIN POWER CIRCUIT TROUBLESHOOTING**

---

Machine Will Not Power Up . . . . .	6-32
-------------------------------------	------

**MAST TROUBLESHOOTING**

---

Platform Will Not Lower Manually . . . . .	6-33
Platform Lift Up And Down Jerky . . . . .	6-33
Mast Noisy When Lifting And Lowering . . . . .	6-34
Platform (Mast) Won't Stay Elevated . . . . .	6-35
Platform (Mast) Descends Too Slowly . . . . .	6-35

**HYDRAULIC LEAK TROUBLESHOOTING**

---

Miscellaneous Hydraulic Leak Troubleshooting . . . . .	6-36
--	------

**BASE FRAME COMPONENTS TROUBLESHOOTING**

---

Caster Wheels Not Operating Freely . . . . .	6-37
Pot Hole Protection (PHP) Bars will not Lower . . . . .	6-37

**DRIVE SYSTEM TROUBLESHOOTING**

---

Won't Climb Grade . . . . .	6-38
Machine Drives in Opposite Direction . . . . .	6-39
Machine Won't Drive Straight. . . . .	6-40
Noise From Drive Assembly. . . . .	6-41

## SECTION 6 - TROUBLESHOOTING

### 6.6 SPECIFICATIONS FOR VARIOUS COMPONENTS

The following table contains specifications for DVL Series and DVSP machine components.

**Table 6-2. Ohm Ratings for Various Components**

COMPONENT	NOMINAL RESISTANCE @ TEMPERATURE	RESISTANCE RANGE POSSIBLE
Pump Motor	0.2ohm - 0.4ohm @ 77deg F	0.12ohm - 0.49ohm
Brake Coil	44.7ohm - 52ohm @ 68deg F	31.4ohm - 65.3ohm
Drive Motor (Bodine)	.1 to .3ohm (Can change depending on the rotation of the armature and temperature.)	N/A

**Table 6-3. Amperage Draw for Various Components**

COMPONENT	AMPERAGE		
Ground Control Module	20DVL - 95 Amps @ room temperature with rated load 15DVSP - 110 Amps @ room temperature with rated load		
Traction Control Module	LEVEL SURFACE (24V) (RATED LOAD)	15% GRADE (24V) (RATED LOAD)	NO LOAD (24V)
	7 to 11 Amps (per motor)	55 to 60 Amps (per motor)	3.5 to 4.8 Amps 78 to 86 RPM

### 6.7 SPECIAL PIN EXTRACTOR TOOLS FOR ELECTRICAL CONNECTORS

The following table contains pin extractor tools for DVL Series and DVSP machine electrical connector components.

**Table 6-4. Special Pin Extractor Tools for Electrical Connectors**

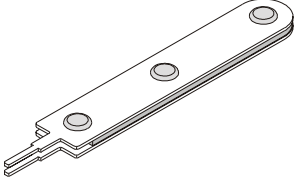
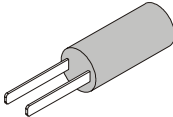
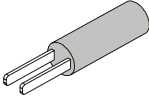
COMPONENT	DESCRIPTION	JLG PART NUMBER	ILLUSTRATION
Ground Control Station	For removal of electrical connector pins from the Ground Control Station connectors.	7016618	
Drive Motor	For removal of electrical connector pins from the Drive Motor main power connectors.	7002841	
Drive Motor Brake	For removal of electrical connector pins from the Drive Motor Brake power connectors.	7002842	

## 6.8 FAULT CODE TROUBLESHOOTING TABLES

### Machine in Drive Speed Cut-Back (Turtle) Mode All The Time

#### Overview of Procedure

Under normal machine operation once the platform is elevated the machine's maximum drive speed is reduced to 1/4 the normal drive speed of when the platform is fully lowered. This is detected with a drive speed cut-back (*proximity*) switch mounted at the base of the mast assembly and a target mounted on the mast assembly. When the mast is elevated and the target raised the proximity switch then cuts back the machine drive speed. When machine is in the drive speed cut-back mode a turtle is displayed on the Ground Control Module LCD display.

#### Check For These Obvious Conditions First:

- Mast drive speed cut-back (proximity) switch and target plate secure and undamaged.
- Both Pot Hole Protection Bar Limit switches secure and undamaged.

**Table 6-5. Machine In Drive Speed Cut-Back (Turtle) Mode All The Time**

STEP	ACTION	SPEC	YES	NO
1.	The Pot-Hole-Protection system bars should be raised when the platform is fully lowered. Check if the Pot-Hole-Protection bars are down when the platform is fully lowered.	—	Check the mechanical operation of the PHP System	Go to Step 2
2.	With the platform fully lowered, check for continuity on the Cutback Proximity Switch wires between pins-8 and 18 on the P2 connector at the Ground Control Module.	—	Go to Step 3	Repair or Replace Speed Cutback (Proximity) Switch
3.	With the platform fully lowered, bars raised, check for continuity on the Right Side PHP bar limit switch, between pins-9 and 19 on the P2 connector at the Ground Control Module.	—	Repair or Replace Right Side PHP Limit Switch Go to Step 4	
4.	With the platform fully lowered, bars raised, check for continuity on the Left Side PHP bar limit switch, between pins-10 and 20 on the P2 connector at the Ground Control Module.	—	Repair or Replace Left Side PHP Limit Switch	

**Obstruction Sensor System - Detection**

**Check For These Obvious Conditions First:**

- Look for an obstruction under platform, remove obstruction.
- Check for any external damage to sensor(s) or wiring harness.
- Are the O.S.S. side shield tubes secure to platform frame and not loose or protruding into the sensor detection area?
- Are the isolation bushings in place and undamaged on both the O.S.S. Module and each of the detection sensors?
- Are the detection sensor mounting screws properly tightened (*not over torqued*) so not to damage the isolation bushings? Also check that none of the sensor mounting screws are bent, thereby touching the inside of the sensor mounting holes.
- Are any of the "Do not pressure wash" decals loose and protruding into the sensor detection area?

**Table 6-6. Obstruction Sensor System - Detection**

STEP	ACTION	SPEC	YES	NO
1.	Perform Daily Pre-Start Inspection to test each transducer sensor. Did all sensors pass test?	—	Go to Step 2	Replace Sensor
2.	Disconnect the OSS Control Module connection to the Platform Junction Box mounted on the mast platform header section above the OSS Control Module. Does the Ground Control Module now show a Fault Code 5?	—	Go to Step 3	Replace Ground Control Module
3.	Reconnect the OSS Control Module connection to the Platform Junction Box. Check for original fault condition.	—	Replace OSS System	—



**Battery Voltage Low - Warning Level 3 - Three (3) LED/LCDs lit**

- 3 LEDs/BARS Flashing with an audible beep.
- Machine will Operate - No Control Functions are Locked Out.

When batteries are drained to Warning Level 3, charge batteries until a level of four (4) LEDs-(Platform) or BARS (Ground Control Module), or more before operating. Failure to do so, will eventually result in a fault Code 38 - Battery Voltage Low - Warning Level 2.

**NOTE:** If battery is not charging properly, see *Battery/Battery Charger Servicing - Section 3 of this Manual.*

**Code 02 - Left PHP Bar - UP****Check For These Obvious Conditions First:**

- Obstruction under LEFT pot hole bar.
- Obstruction around the actuator assembly at the base of the mast.

Table 6-7. Code 02 - Left PHP Bar - UP

STEP	ACTION	SPEC	YES	NO
<b>CHECK THE FOLLOWING WITH THE PLATFORM ELEVATED 3 TO 4 FEET (1 TO 1.5m)</b>				
1.	Go to the 20 pin molex connector at the Ground Control Module, back probe to check for continuity of pin 10, (BLK #8 wire) with pin 20, (ORG/RED 49-1 wire). Is there continuity?	—	Replace Ground Control Module	Go to Step 2
2.	Check the actuator cables for adjustment or damage.	—	Adjust or Replace	Go to Step 3
3.	Check the PHP limit switch(s) at both sides of the machine for damage, adjustment and for continuity through switch to ground when bars are down.	—	Replace, Adjust or Repair Wiring	—

**Code 03 - Right PHP Bar - UP****Check For These Obvious Conditions First:**

- Obstruction under RIGHT pot hole bar.
- Obstruction around the actuator assembly at the base of the mast.

Table 6-8. Code 03 - Right PHP Bar - UP

STEP	ACTION	SPEC	YES	NO
<b>CHECK THE FOLLOWING WITH THE PLATFORM ELEVATED 3 TO 4 FEET (1 TO 1.5m)</b>				
1.	Go to the 20 pin molex connector at the Ground Control Module, back probe to check for continuity of pin 9, (BLK #9 wire) with pin 19, (ORG/RED 49-2 wire). Is there continuity?	—	Replace Ground Control Module	Go to Step 2
2.	Check the actuator cables for adjustment or damage.	—	Adjust or Replace	Go to Step 3
3.	Check the PHP limit switch(s) at both sides of the machine for damage, adjustment and for continuity through switch to ground when bars are down.	—	Replace, Adjust or Repair Wiring	—

## SECTION 6 - TROUBLESHOOTING



### Code 04 - Tilt Condition

#### Check For These Obvious Conditions First:

- If machine is on a tilt of more than 1.5° in either or both the X or Y direction, this is normal operation. (DRIVE and LIFT UP are disabled when tilt is detected)
- Check if Ground Control Module is mounted securely to the mast support column.

Table 6-9. Code 04 - Tilt Condition

STEP	ACTION	SPEC	YES	NO
1.	Using a digital level check the actual level of the machines' resting surface in both the X and the Y directions. Does surface check within machine specification.	1.5° X and Y Direction	Go to Step 2	Drive Machine to Level Surface
2.	At the Ground Control Module, enter the programming mode (See Ground Control Programming, Section-3 of Service Manual) and check the tilt sensor X and Y readings. Are readings within machine specification?	1.5° X and Y Direction	Replace Ground Control Module	Go to Step 3
3.	Zero Tilt Sensor on a surface checked to within 0.0 degrees with a digital level in both the X and Y directions. (See Ground Control Programming, Section-3 of Service Manual).	—	—	—

**NOTE:** If frequent calibration of the internal Tilt Sensor is required, replace the Ground Control Module.



### Code 05 - Reserved



### Code 06 - Reserved



### Code 07- Left Drive Motor - Disconnected

#### Check For These Obvious Conditions First:

- Check left drive motor M1 connector at the Traction Control Module for secure and proper connection.

Table 6-10. Code 07 - Left Drive Motor - Disconnected

STEP	ACTION	SPEC	YES	NO
1.	Check resistance across positive (+) and negative (-) drive motor leads in M1 connector wiring harness going to the left drive motor. Is reading within spec?	.1 to .3 ohms	Replace Traction Module	Go to Step 2
2.	Repair or replace left drive motor wiring, brushes or motor. (For brush replacement, see Section 3 of this Service Manual)	—	—	—



 **Code 08 - Right Drive Motor - Disconnected**

**Check For These Obvious Conditions First:**

- Check right drive motor M2 connector at the Traction Control Module for secure and proper connection.

**Table 6-11. Code 08 - Right Drive Motor Disconnected**

STEP	ACTION	SPEC	YES	NO
1.	Check resistance across positive (+) and negative (-) leads in M2 connector wiring harness going to the right drive motor. Is reading within spec?	.1 to .3 ohms	Replace Traction Module	Go to Step 2
2.	Repair or replace right drive motor wiring, brushes or motor. (For brush replacement, see Section 3 of this Service Manual)	—	—	—

 **Code 09 - Left Brake - Disconnected**

**Check For These Obvious Conditions First:**

- Check left drive motor M1 connector at the Traction Control Module for secure and proper connection.

**Table 6-12. Code 09 - Left Brake - Disconnected**

STEP	ACTION	SPEC	YES	NO
1.	Check resistance across positive (+) and negative (-) leads in M1 connector wiring harness going to the left drive motor brake assembly. Is reading within spec?	See Table 6-2	Replace Traction Module	Go to Step 2
2.	Repair or replace left brake wiring or left brake assembly.	—	—	—

 **Code 10 - Right Brake - Disconnected**

**Check For These Obvious Conditions First:**

- Check right drive motor M2 connector at the Traction Control Module for secure and proper connection.

**Table 6-13. Code 10 - Right Brake - Disconnected**

STEP	ACTION	SPEC	YES	NO
1.	Check resistance across positive (+) and negative (-) leads in M2 connector wiring harness going to the right drive motor brake assembly. Is reading within spec?	See Table 6-2	Replace Traction Module	Go to Step 2
2.	Repair or replace right brake wiring or right brake assembly.	—	—	—

## SECTION 6 - TROUBLESHOOTING



### Code 11 - Left Drive Motor - Short Circuit

**Check For These Obvious Conditions First:**

- Wiring harness from (M1) connector on Traction Control Module to Left Drive Motor for damage.

**Table 6-14. Code 11 - Left Drive Motor - Short Circuit**

STEP	ACTION	SPEC	YES	NO
1.	Remove the M1 connector from the Traction Control Module and check both the pins to the drive motor for any voltage. (Ground the meter to the Ground Control Module - Negative (-) lug.)	No Voltage	This circuit should be isolated. Repair or Replace Components as Required	Go to Step 2
2.	Check for continuity of both the pins to ground.	No Ground		Replace Traction Control Module



### Code 12 - Right Drive Motor - Short Circuit

**Check For These Obvious Conditions First:**

- Wiring harness from (M2) connector on Traction Control Module to Left Drive Motor for damage.

**Table 6-15. Code 12 - Right Drive Motor - Short Circuit**

STEP	ACTION	SPEC	YES	NO
1.	Remove the M2 connector from the Traction Control Module and check both the pins to the drive motor for any voltage. (Ground the meter to the Ground Control Module - Negative (-) lug.)	No Voltage	This circuit should be isolated. Repair or Replace Components as Required	Go to Step 2
2.	Check for continuity of both the pins to the drive motor to ground.	No Ground		Replace Traction Control Module



### Code 13 - Traction Module - In Fold Back

**Check For These Obvious Conditions First:**

- Machine is operating on a continuous grade or rough terrain.

**Table 6-16. Code 13 - Traction Module - In Fold Back**

STEP	ACTION	SPEC	YES	NO
1.	Allow machine to cool the traction module for 30 minutes. Does the machine operate OK after cooling.	—	—	Replace Traction Module

**NOTE:** If this is a recurring problem compare current draw of your machine with Traction Control Module specifications in Table 6-3 - Amperage Draw for Various Components.

**Code 14 - Pump Motor - Disconnected****Check For These Obvious Conditions First:**

- Check the Positive (+)/Negative (-) cables from the Ground Control Module to the Pump Motor studs for loose or corroded connections.

**Table 6-17. Code 14 - Pump Motor - Disconnected**

STEP	ACTION	SPEC	YES	NO
1.	Check resistance across the positive (+) and negative (-) studs on the pump motor.	See Table 6-2	Replace Ground Control Module	Repair or Replace Pump Motor or Motor Brushes

**Code 15 - Lift Down Valve - Disconnected****Check For These Obvious Conditions First:**

- Inspect wire terminals on the lift down valve at the base of the lift cylinder for tight and secure connection.

**Table 6-18. Code 15 - Lift Down Valve - Disconnected**

STEP	ACTION	SPEC	YES	NO
1.	Check voltage at the P1 connector on the Ground Control Module between pin-10 and pin-3. Is reading within spec?	2 - 4 V DC	Replace Ground Control Module	Go to Step 2
2.	Check resistance between the terminals on the lift down valve, located at the base of the lift cylinder. Is reading within spec?	24.5 Ohms	Repair or Replace Wiring Harness from Ground Control Module	Replace the Lift Down Valve Solenoid
3.	With the terminals still removed from the lift down valve coil, check continuity of the wires from pins 10 and 3 on the P1 connector to the lift down valve.	.00 Ohms	—	Repair or Replace Wiring

## SECTION 6 - TROUBLESHOOTING



### Code 16 - Lift Down Valve - Short Circuit

**Check For These Obvious Conditions First:**

- Damaged wiring in the lift down valve wiring harness or a damaged lift down valve coil.

**Table 6-19. Code 16 - Lift Down Valve - Short Circuit**

STEP	ACTION	SPEC	YES	NO
1.	At the Ground Control Module, P1 connector, check the voltage across pins 10 and 3 to the lift down valve coil. Is reading within specification?	0 - 2V DC	Go to Step 2	Replace Ground Control Module
2.	Remove the wire terminals at the lift down valve coil. Check resistance reading of the coil. Is coil within specification?	24.5 Ohms	Go to Step 3	Replace Coil
3.	With the terminals still removed from the lift down valve coil, check continuity of the wires from pins 10 and 3 on the P1 connector to the lift down valve.	.00 Ohms	—	Repair or Replace Wiring



### Code 17 - Ground Control Module - In Fold Back

**Check For These Obvious Conditions First:**

- Has machine been operating on a continuous grade or rough terrain for a long period of time.

**Table 6-20. Code 17 - Ground Control Module - In Fold Back**

STEP	ACTION	SPEC	YES	NO
1.	Allow Ground Control Module to cool for 30 minutes. Does the machine operate OK after cooling.	—	—	Replace Ground Control Module
<b>NOTE:</b> <i>If this is a recurring problem compare current draw of your machine with Ground Control Module specifications in Table 6-3 - Amperage Draw for Various Components.</i>				



### Code 18 - Alarm - Short Circuit

**Check For These Obvious Conditions First:**

- Damaged wiring in the alarm wiring harness or a damaged alarm.

**Table 6-21. Code 18 - Alarm - Short Circuit**

STEP	ACTION	SPEC	YES	NO
1.	At the Ground Control Module, P1 connector, check the voltage across pins-13 and 6 to the alarm. Is reading within specification?	0 - 2V DC	Go to Step 2	Replace Ground Control Module
2.	Remove the wire terminals at the alarm, check continuity of each of the wires from pins 13 and 6 on the P1 connector to the alarm end.	—	Replace the Alarm	Repair or Replace Wiring

**Code 19 - Alarm - Disconnected****Check For These Obvious Conditions First:**

- Damaged wiring in the alarm wiring harness or a damaged alarm.
- Activate a function to check if alarm beeps.

**Table 6-22. Code 19 - Alarm - Disconnected**

STEP	ACTION	SPEC	YES	NO
1.	Check voltage at the P1 connector on the Ground Control Module between pin-13 and pin-6. Is reading within specification?	2 - 4V DC	Replace Ground Control Module	Go to Step 2
2.	Remove the wire terminals at the alarm, check continuity of each of the wires from pins 13 and 6 on the P1 connector to the alarm end.	—	Replace the Alarm	Repair or Replace Wiring

**Code 20 - Beacon - Short Circuit****Check For These Obvious Conditions First:**

- Damaged wiring in the beacon wiring harness or a damaged beacon unit.

**Table 6-23. Code 20 - Beacon - Short Circuit**

STEP	ACTION	SPEC	YES	NO
1.	At the Ground Control Module, P1 connector, check the voltage across pins-12 and 5 to the beacon. Is reading within specification?	0 - 2V DC	Go to Step 2	Replace Ground Control Module
2.	Remove the wire terminals at the beacon, check continuity of each of the wires from pins 12 and 5 on the P1 connector to the beacon end.	—	Replace the Beacon	Repair or Replace Wiring

## SECTION 6 - TROUBLESHOOTING



### Code 21 - Beacon - Disconnected

#### Check For These Obvious Conditions First:

- Is machine equipped with flashing amber beacon light.

Table 6-24. Code 21 - Beacon - Short Disconnected

STEP	ACTION	SPEC	YES	NO
1.	Is machine equipped with a flashing amber beacon light.	—	Go to Step 3	Got to Step 2
2.	At the Ground Control Module enter the programming mode, check if the Beacon light open circuit detection is enabled.	—	Disable It	Replace Ground Control Module
3.	Check voltage at the P1 connector on the Ground Control Module between pin-12 and pin-5. Is reading within specification?	2 - 4 V DC	Replace Ground Control Module	Go to Step 4
4.	Remove the wire terminals at the beacon, check continuity of each of the wires from pins-12 and 5 on the P1 connector to the beacon end.	—	Replace the Beacon	Repair or Replace Wiring



### Code 22 - Horn - Short Circuit

#### Check For These Obvious Conditions First:

- Damaged wiring in the horn wiring harness or a damaged horn unit.

Table 6-25. Code 22 - Horn - Short Circuit

STEP	ACTION	SPEC	YES	NO
1.	At the Ground Control Module, P1 connector, check the voltage across pins-14 and 7 to the horn. Is reading within specification?	0 - 2V DC	Go to Step 2	Replace Ground Control Module
2.	Remove the wire terminals at the horn, check continuity of each of the wires from pins-14 and 7 on the P1 connector to the horn end.	—	Replace the Horn	Repair or Replace Wiring

**Code 23 - Horn - Disconnected****Check For These Obvious Conditions First:**

- Is machine equipped with a horn unit.

**Table 6-26. Code 23 - Horn - Disconnected**

STEP	ACTION	SPEC	YES	NO
1.	Is machine equipped with a horn unit.	—	Go to Step 3	Got to Step 2
2.	At the Ground Control Module enter the programming mode, check if the horn open circuit detection is enabled.	—	Disable It	Replace Ground Control Module
3.	Check voltage at the P1 connector on the Ground Control Module between pin-14 and pin-7. Is reading within specification?	2 - 4 V DC	Replace Ground Control Module	Go to Step 4
4.	Remove the wire terminals at the horn, check continuity of each of the wires from pins-14 and 7 on the P1 connector to the horn end.	—	Replace the Horn	Repair or Replace Wiring

**Code 24 - Auxiliary #1 Circuit - Short Circuit****Check For These Obvious Conditions First:**

- Damaged wiring in the Auxiliary #1 Component wiring harness or a damaged Component.

**Table 6-27. Code 24 - Auxiliary #1 Circuit - Short Circuit**

STEP	ACTION	SPEC	YES	NO
1.	At the Ground Control Module, P1 connector, check the voltage across pins-9 and 2 to the horn. Is reading within specification?	0 - 2V DC	Go to Step 2	Replace Ground Control Module
2.	Remove the wire terminals at the horn, check continuity of each of the wires from pins-9 and 2 on the P1 connector to the component end.	—	Replace the Component	Repair or Replace Wiring

## SECTION 6 - TROUBLESHOOTING



### Code 25 - Auxiliary #1 Circuit - Disconnected

#### Check For These Obvious Conditions First:

- Is machine equipped with a component on the Auxiliary #1 circuit.

Table 6-28. Code 25 - Auxiliary #1 Circuit - Disconnected

STEP	ACTION	SPEC	YES	NO
1.	Is machine equipped with a component on the Auxiliary #1 circuit.	—	Go to Step 3	Got to Step 2
2.	At the Ground Control Module enter the programming mode, check if the Auxiliary #1 open circuit detection is enabled.	Default = NO	Disable It	Replace Ground Control Module
3.	Check voltage at the P1 connector on the Ground Control Module between pin-9 and pin-2. Is reading within specification?	2 - 4 V DC	Replace Ground Control Module	Go to Step 4
4.	Remove the wire terminals at the Aux. #1 component, check continuity of each of the wires from pins-9 and 2 on the P1 connector to the Aux. #1 component.	—	Replace the Component	Repair or Replace Wiring



### Code 26 - Auxiliary #2 - Short Circuit

#### Check For These Obvious Conditions First:

- Damaged wiring in the Auxiliary #2 Component wiring harness or a damaged Component.

Table 6-29. Code 26 - Auxiliary #2 - Short Circuit

STEP	ACTION	SPEC	YES	NO
1.	At the Ground Control Module, P1 connector, check the voltage across pins-8 and 1 to the Aux. #2 component. Is reading within specification?	0 - 2V DC	Go to Step 2	Replace Ground Control Module
2.	Remove the wire terminals at the Aux. #2 component, check continuity of each of the wires from pins-8 and 1 on the P1 connector to the Aux. #2 component end.	—	Replace the Component	Repair or Replace Wiring



**Code 27 - Auxiliary #2 - Disconnected****Check For These Obvious Conditions First:**

- Is machine equipped with a component on the Auxiliary #2 circuit.

**Table 6-30. Code 27 - Auxiliary #2 - Disconnected**

STEP	ACTION	SPEC	YES	NO
1.	Is machine equipped with a component on the Auxiliary #2 circuit.	—	Go to Step 3	Got to Step 2
2.	At the Ground Control Module enter the programming mode, check if the Auxiliary #2 open circuit detection is enabled.	Default = NO	Disable It	Replace Ground Control Module
3.	Check voltage at the P1 connector on the Ground Control Module between pin-8 and pin-1. Is reading within specification?	2 - 4 V DC	Replace Ground Control Module	Go to Step 4
4.	Remove the wire terminals at the Aux. #2 component, check continuity of each of the wires from pins-8 and 1 on the P1 connector to the Aux. #2 component.	—	Replace the Component	Repair or Replace Wiring

**Code 28 - Reserved****Code 29 - Reserved**



**Code 30 - Traction Module - No Communication with Ground Control Module**

**Check For These Obvious Conditions First:**

- Check if the communications cable connections, P5 connector on the Ground Control Module and round plug on the Traction Control Module are seated properly in their sockets at each end.
- Check the Positive (+) (RED) and Negative (-) (BLACK) power cable connections from the Ground Control Module to the Traction Control Module are tight and secure at both ends.

**Table 6-31. Code 30 - Traction Module - No Communication with Ground Control Module**

STEP	ACTION	SPEC	YES	NO
1.	Check the voltage reading at the main power Positive (+)/Negative (-) cable connection on the Traction Control Module.	24v DC	Go to Step 2	Repair or Replace Positive (+) or Negative (-) Cable
2.	Remove the communications cable, P5 connector at the Ground Control Module and round connector at the Traction Control Module. Check continuity of all three (3) wires in the communications cable from end to end. P5 - Pins 2, 3, and 4.	—	Go to Step 3	Repair or Replace Wire(s)
3.	With communications cable disconnected at both ends, check for continuity between Pins 2, 3, and 4 of the P5 connector end.	—	Repair or Replace Wires	Go to Step 4
4.	Plug the communications cable on the Traction Control Module to the round socket on the opposite end of the module. Does this fix problem?	—	Done	Replace Traction Control Module
5.	Unplug the P5 connector at the Ground Control Module. Check voltage between pins 2 (- lead-in) and 5 (+ lead-in). Is voltage within spec.	4.5v DC	Done	Replace Ground Control Module

**Code 31 - Platform Control Console - No Communication with Ground Control Module****Check For These Obvious Conditions First:**

- Check the harness connection at the P4 connector on the Ground Control Module and the harness connection at the other end on the Platform Junction Box.

**Table 6-32. Code 31 - Platform Control Console - No Communication with Ground Control Module**

STEP	ACTION	SPEC	YES	NO
1.	Check if LEDs are illuminated on the Platform Control Console.	—	Go To Step 2	Go to Step 3
2.	Remove the 9 pin Platform Control Console connector from the side of the Platform Junction Box and the P4 connector at the Ground Control Module. Check continuity from the P4 connector, pin-5 to Junction Box pin-3 and P4, pin-9 to Junction Box pin-4.	—	Repair or Replace Platform Control Console	Repair or Replace Wiring
3.	Remove the 9 pin Platform Control Console connector from the side of the Platform Junction Box. Check the voltage across pins-1 and 5 in the Junction Box connector.	24V DC	Repair or Replace Platform Control Console	Go to Step 4
4.	Check voltage across pins-10 and 2 on connector P4 at the Ground Control Module.	24V DC	Go to Step 5	Replace Ground Control Module
5.	Check continuity of P4 connector, pin-10 to Platform Junction Box pin-1. Also P4 connector, pin-2 to Platform Junction Box, pin-5.	—	Repair or Replace Wires	

**Code 32 - Pump Motor - Over Current****Check For These Obvious Conditions First:**

- Platform overload condition.
- Obstruction in mast system.
- Pump Positive (+) and Negative (-) connections are secure and undamaged.
- Crushed or kinked hydraulic lines.
- Hydraulic leaks.

**Table 6-33. Code 32 - Pump Motor - Over Current**

STEP	ACTION	SPEC	YES	NO
1.	Check current draw of pump motor by elevating the platform to full height and load pump by continuing to press the UP button. Is reading within spec?	Less than 145 Amps	Go to Step 2	Go to Step 3
2.	Did unit give a 32 Fault Code while performing Step 1?	—	Replace Ground Control Module	—
3.	Is the pump hydraulic pressure setting within specification as show in Section 1.6 of this Service Manual?	See Section 1.6	Go to Step 4	Adjust to Specification
4.	Check pump motor brushes and rotor commutator for abnormal wear.	—	Replace as Required	Replace Pump Motor



**Code 33 - Both PHP Bars - UP**

---

**Table 6-34. Code 33 - Both PHP Bars - UP**

STEP	ACTION	SPEC	YES	NO
1.	Perform steps in Code 2, Left PHP Bar UP then, Code 3, Right PHP Bar UP. Do either of these steps correct the problem?	—	Done	Go to Step 2
2.	Perform steps in Table 6-5 - Machine In Drive Speed Cut-Back (Turtle) Mode All The Time, of this section.	—	Done	Consult Factory



**Code 38 - Battery Voltage Low - Warning Level 2 - Two (2) LED/LCDs lit**

---

To maximize battery life, it is recommended that the factory supplied batteries be charged continuously for a minimum of 4 hours or until 8 bars are lit on the ground station LCD Display before operating the machine. When drained to Warning Level 2, batteries must be charged until 8 bars are lit on the ground station LCD display to clear the fault code. Failure to do so, will result in a fault code 39.



**Code 39 - Battery Voltage Low - Warning Level 3 - One (1) LED/LCDs lit**

---

To maximize battery life, it is recommended that the factory supplied batteries be charged continuously for a minimum of 4 hours or until 8 bars are lit on the ground station LCD Display before operating the machine. When drained to Warning Level 1, batteries must be charged until 8 bars are lit on the ground station LCD display to clear the fault code.



## Code 40 - Obstruction Sensor System - No Communication with Ground Control Module

### Check For These Obvious Conditions First:

- Is machine equipped with an Obstruction Sensor System?
- Are the electrical harness connectors from the OSS Module through the Platform Junction Box to the Ground Control Module tight and undamaged?

Table 6-35. Code 40 - OSS - No Communication with Ground Control Module

STEP	ACTION	SPEC	YES	NO
1.	Is machine equipped with an OSS system?	—	Got to Step 4	Go to Step 2
2.	At the Ground Control Module, enter programming mode and view if OSS is enabled. Is OSS enabled?	X = No	Go to Step 3	Replace Ground Control Module
3.	In Service Level Programming mode, Disable Obstruction Sensor System.	X=No	—	—
4.	With machine powered up, check if the RED LED is lit on the front of the OSS Module.	—	Go to Step 5	Go to Step 10
5.	Check continuity from pin-9 on the OSS module (9-pin connector) to the platform junction box pin-2 (4-pin connector).	—	Go To Step 6	Inspect Wiring and Harness Connectors
6.	Check continuity from platform junction box pin-2 (4-pin connector) to the Ground Control Module (P-4 connector) pin-7.	—	Go to Step 7	Inspect Wiring and Harness Connectors
7.	Check continuity from pin-9 on OSS module (9-pin connector) to the Ground Control Module (P-4 connector) pin-7.	—	Go to Step 8	Inspect Connection at the Platform Junction Box
8.	Program the Ground Control Module to Disable the OSS System. Does fault condition still appear?	—	Replace the Ground Control Module	Go to Step 9
9.	Replace the Obstruction Sensor System and check for fault.	—	Replace the Ground Control Module	—
10.	Disconnect 9-pin connector at the OSS Module. Place a positive (+) lead on Pin-1 and a negative (-) lead on pin-5. Check for 24v DC.	24V (DC)	Replace the OSS Module	Go to Step 11
11.	Check the wiring harness from the Platform Junction Box connector to the Ground Control Module, positive (+) lead on pin-1 to negative (-) lead on pin-4. Check for 24v DC.	24V (DC)	Repair or Replace, OSS to Junction Box Wire Harness	Go to Step 12

## SECTION 6 - TROUBLESHOOTING

Table 6-35. Code 40 - OSS - No Communication with Ground Control Module (Continued)

STEP	ACTION	SPEC	YES	NO
12.	At the Ground Control Module (P-4 connector) check voltage between pin-8 and pin-2, place positive (+) lead on pin-8.	24V (DC)	Repair or Replace, Junction Box to Ground Control Module Wire Harness	Replace Ground Control Module



### Codes 41 thru 46 - OSS - Sensor 1 through 6 - Fault Condition

**Check For These Obvious Conditions First:**

- Is there an obstruction under the sensor showing the fault?
- Is the faulted sensor mounted properly and securely to the platform base frame?

Table 6-36. Codes 41 thru 46 - OSS - Sensor 1 through 6 - Fault Condition

STEP	ACTION	SPEC	YES	NO
1.	Is machine equipped with an OSS system?	—	Got to Step 4	Go to Step 2
2.	At the Ground Control Module, enter programming mode and view if OSS is enabled. Is OSS enabled?	X = No	Go to Step 3	Replace Ground Control Module
3.	In Service Level Programming mode, Disable Obstruction Sensor System.	X=No	—	Go to Step 4
4.	Replace the sensor showing the fault. Does this correct the problem.	—	Done	Go to Step 5
5.	Replace the complete OSS system, module and sensors.	—	—	—



### Codes (100 - 199) Ground Control Module - Fault Condition

#### Check For These Obvious Conditions First:

- That all battery and harness connectors secure and undamaged on Ground Control Module.
- Batteries have sufficient charge.
- Confirm that the static ground strap attached under base frame is secure and undamaged.

**Table 6-37. Codes (100 - 199) Ground Control Module - Fault Condition**

STEP	ACTION	SPEC	YES	NO
1.	Recycle machine power 5 times allowing a 10 second interval between each power recycle. Does fault clear?	—	Done	Go to Step 2
2.	Which code number is displaying?	Code 103	Go to Step 3	Replace Ground Control Module
		Code 119	Go to Step 5	
3.	Confirm that both installed batteries are 12 Volt DC.	12V DC	Go to Step 4	Replace with proper Batteries
4.	Check battery voltage while charger is operating. Is voltage within specification?	Maximum of 31 Volts DC	Replace Ground Control Module	Repair or Replace Battery Charger
5.	Remove the communications cable, P5 connector at the Ground Control Module and round connector at the Traction Control Module. Check continuity of all three (3) wires in the communications cable from end to end. P5 - Pins 2, 3, and 4.	—	Go to Step 6	Repair or Replace Wire(s)
6.	With communications cable still disconnected at both ends, check for continuity between Pins 2, 3, and 4 at the P5 connector end.	—	Repair or Replace Wires	Go to Step 7
7.	Plug the communications cable on the Traction Control Module to the round socket on the opposite end of the module. Does this fix problem?	—	Done	Replace Ground Control Module

## SECTION 6 - TROUBLESHOOTING



### Codes (200 - 299) Platform Control Console - Fault Condition

#### Check For These Obvious Conditions First:

- Damage to Platform Control Console wiring harness.
- Secure harness connections from Platform Control Console to Platform Junction Box to Ground Control Module.
- Confirm that the static ground strap attached under base frame is secure and undamaged.

**Table 6-38. Code (200 - 299) Platform Control Console - Fault Condition**

STEP	ACTION	SPEC	YES	NO
1.	Recycle machine power 5 times allowing a 10 second interval between each power recycle. Does fault clear?	—	Done	Go to Step 2
2.	Which 200 code number is displaying?	Code - 200/207/213	Go to Step 3	Replace Platform Control Module
		Code - 202/205/206	Go to Step 4	
3.	Remove the 9 pin Platform Control Module connector from the side of the Platform Junction Box and the P4 connector at the Ground Control Module. Check continuity from the P4 connector, pin-5 to Junction Box pin-3 and P4, pin-9 to Junction Box pin-4. Is there continuity on these wires?	—	Replace Platform Control Module	Repair or Replace Wiring
4.	Perform the Joystick Calibration Procedure in Section 4.5 of this Service Manual. Does this clear the fault code?	—	Done	Replace Platform Control Module





### Codes (300 - 399) Traction Control Module - Fault Condition

#### Check For These Obvious Conditions First:

- Damage to Traction Control Module wiring harness.
- Confirm that the static ground strap attached under base frame is secure and undamaged.

Table 6-39. Codes (300 - 399) Traction Control Module - Fault Condition

STEP	ACTION	SPEC	YES	NO
1.	Recycle machine power 5 times allowing a 10 second interval between each power recycle. Does fault clear?	—	Done	Go to Step 2
2.	Is a code number displaying on the Ground Control Station?	Code - 316	Go to Step 3	Replace Traction Control Module
		Code - 325	Go to Step 5	—
3.	Confirm that both installed batteries are 12 Volt DC.	12V DC	Go to Step 4	Replace with proper Batteries
4.	Check battery voltage while charger is operating. Is voltage within specification?	Maximum of 31 Volts DC	Replace Traction Control Module	Repair or Replace Battery Charger
5.	Check for short in harness wires from Ground Control Station connector P5 to Traction Module ( <i>round din plug</i> ). <i>Note: This harness contains 6 wires only 3 are used, (See Figure 6-3.) Electrical Diagram.</i>	—	Repair or Replace Wiring	—

6.9 MAIN POWER CIRCUIT TROUBLESHOOTING

Machine Will Not Power Up

Check For These Obvious Conditions First:

- Battery voltage is 24 volts. (Sufficient Charge in Batteries to Operate Machine)
- Positive (+) and negative (-) battery cable connections clean and tight at both the Batteries and the Ground Control Module lugs.
- Main Power Selector Switch (key) positioned to either Platform or Ground Control Mode.
- Emergency stop buttons on both the Ground Control Module and the Platform Control Console in the RESET position (out).

Table 6-40. Machine Will Not Power UP.

STEP	ACTION	SPEC	YES	NO
1.	Check for 24V DC at the positive (+) and negative (-) main power cable connections on the Ground Control Module.	24V DC	Go to Step 2	Replace the 175 Amp Inline Fuse on the Positive power cable
2.	Check continuity of the Emergency Stop wires running to the Platform Control Console, pins-10 and 1 on the P4 connector at the Ground Control Module.	—	Replace the Ground Control Module	Go to Step 3
3.	Remove the 9-pin Platform Control Console connector at the Platform Junction Box and check continuity between pins- 1 and 2 to the Emergency Stop Switch in the Platform Control Console cable.	—	Go to Step 4	Replace the Platform Control Console
4.	Check continuity of the wires running from the P4 connector on Ground Control Module to the Platform Junction Box; P4 connector, Pin-1 to Junction Box Pin-2 and P4 connector, Pin-10 to Junction Box Pin-1	—	Replace Platform Control Console	Repair or Replace Wiring

## 6.10 MAST TROUBLESHOOTING

### Platform Will Not Lower Manually

#### Check For These Obvious Conditions First:

- Is there an obstruction in the mast assembly?
- Is there a restricted hydraulic line (smashed)?
- Are the mast slide pads shimmed properly (not too tight), per Mast Assembly procedure in Service Manual?

**Table 6-41. Platform Will Not Lower Manually.**

STEP	ACTION	SPEC	YES	NO
1.	Check to see if the platform will lower from the Ground Control Station in Ground Control Mode.	—	Repair or Replace the Manual Descent Control Valve	Go to Step 2
2.	Check to see if the lift down valve is opening completely.	—	Go to Step 3	Replace the Lift Down Valve
3.	Check the flow valve in the lift cylinder for a restriction.	—	Clean or Replace Flow Valve	Consult Factory

### Platform Lift Up And Down Jerky

#### Overview Of Procedure

The following procedure suggests areas on the machine which might attribute to erratic movement of the platform during lift up and down.

#### Check For These Obvious Conditions First:

- If mast is not running smooth or has tight and rough spots, refer to the Mast Section Rebuild.
- Hydraulic oil level in reservoir tank at full level.
- Hydraulic oil is not milky (presence of water), or foamy (full of air).

**Table 6-42. Platform Lift Up and Down Jerky**

STEP	ACTION	SPEC	YES	NO
<b>CONTROLS (ELECTRICAL)</b>				
1.	Is platform control console, platform enable, up or down pad defective or worn out?	—	Replace pad	Go to Step 2
2.	Loose connections, ground and power.	—	Repair connection	Go to Step 3
3.	Valve solenoid keeps opening and closing.	—	Repair Connection or Replace Valve	Go to Step 4
4.	Problem internal to the Ground Control Module.	—	Replace Module	Go to Step 5
<b>HYDRAULIC</b>				
5.	Is the hydraulic valve working properly.	—	Go to Step 6	Replace Valve
6.	Pump drive cavating.	—	Replace Pump	Go to Step 7
7.	Lift cylinder	—	Rebuild or Replace Cylinder	—

## SECTION 6 - TROUBLESHOOTING

### Mast Noisy When Lifting And Lowering

#### Overview Of Procedure

This procedure examines components of the mast itself and as well as it's lifting components for dirt, debris, proper lubrication and operation.

**Table 6-43. Mast Noisy when Lifting and Lowering.**

STEP	ACTION	SPEC	YES	NO
1.	Do slide pads and slide pad channels need to be cleaned of dust, dirt, or other debris?	—	Clean Pads and Channels	Go to Step 2
2.	Do mast chains need to be lubricated per JLG specification in the Service Manual?	—	Lubricate as Required	Go to Step 3
3.	Are the chain/cable sheave wheels dry and need lubrication? Note: Plastic wheels will howl on the sheave pin when they are dry. Sheave wheels may seize to the sheave pin and the pin may turn in the pin retainer blocks.	—	Lubricate or Replace Sheave Pins and Wheels	Go to Step 4
4.	Are the sequence cables (located on the side of mast) chattering when the springs are compressed? Note: This noise is normal at the sequence cable sheave wheels when the mast is completely lowered. However if the sequence cable chattering is happening no matter what position the mast is in, it could be a result of the mast being shimmed to tight or dirt and debris in the slide pad channels causing the mast to be tight.	—	Clean Slide Pads/ Channels or Re-shim Mast per Service Manual	Go to Step 5
5.	Is the bore of the lift cylinder dry?	—	Replace Packing or Lift Cylinder	Go to Step 6
6.	Are the bearings in the lift pump motor and pump drive worn?	—	Repair or Replace Pump	Go to Step 7
7.	Are the hydraulic lines vibrating together?	—	Adjust the Position of the Lines	Go to Step 8
8.	Check if the pump motor is loose to it's mounting plate.	—	Tighten pump mounting fasteners	Go to Step 9
9.	Hydraulic oil could be cavatating inside the pump.	—	Repair or Replace Pump	—

## Platform (Mast) Won't Stay Elevated

### Overview Of Procedure

The following procedure requests that the lift down, dump, and pump internal valves be checked to see if any are stuck open, it also examines the lift down and dump valve circuits. Also suggests that the lift cylinder packing could be leaking internally.

### Check For These Obvious Conditions First:

- Manual descent valve is closed tight.

**Table 6-44. Platform (Mast) Won't Stay Elevated.**

STEP	ACTION	SPEC	YES	NO
1.	Is the lift down valve stuck open?	—	Repair or Clean Valve	Go to Step 2
2.	Lift down valves could be open due to incorrect electrical signal.	—	Check Pump Valve Electrical Circuit	Go to Step 3
3.	Oil could be passing around the lift cylinder bore packing.	—	Replace or Rebuild the Lift Cylinder	—

## Platform (Mast) Descends Too Slowly

### Overview Of Procedure

The following procedure examines the mast some hydraulic components for obstructions and defects.

**Table 6-45. Platform (Mast) Descends Too Slowly.**

STEP	ACTION	SPEC	YES	NO
1.	Check mast slide pads shimmed to tight.	—	Reshim Mast	Go to Step 2
2.	Is there an obstruction in the mast?	—	Remove Obstruction	Go to Step 3
3.	The lift cylinder packing could be too tight in the bore of the cylinder barrel.	—	Rebuild or Replace Cylinder	Go to Step 4
4.	Check if the lift down valve is opening completely.	—	Clean or Replace Valve	Go to Step 5
5.	Is there a restricted hydraulic line (smashed)?	—	Replace Hydraulic Line	Go to Step 6
6.	Check the flow valve in the cylinder valve block for a restriction, i.e. dirt.	—	Clean or Replace Flow Valve	—

**6.11 HYDRAULIC LEAK TROUBLESHOOTING**

**Miscellaneous Hydraulic Leak Troubleshooting**

**Overview Of Procedure**

This series of steps gives remedies for various areas of the machine where leaks could occur.

**Table 6-46. Hydraulic Leak Troubleshooting**

STEP	ACTION	SPEC	YES	NO
1.	Oil leaking around the lift cylinder rod.	—	Replace the Seal at the end of the Piston and Cylinder Barrel	—
2.	Oil leaking around the cylinder extend or return line fittings.	—	Tighten or Replace Fittings	—
3.	Oil leaking around the hydraulic lines.	—	Tighten or Replace Hydraulic Lines	—
4.	Oil leaking around the lift down valve.	—	Tighten Cartridge in Pump Case	—
5.	Oil leaking around the (Red) manual descent valve.	—	Replace Lift Down Valve	—
<p>Note: Do not overtighten the nut on the solenoid in step 5.</p>				

---

**6.12 BASE FRAME COMPONENTS TROUBLESHOOTING**

---

**Caster Wheels Not Operating Freely**

---

**Check For These Obvious Conditions First:**

- Is machine operating on a smooth, level surface?

**Table 6-47. Caster Wheels Not Operating Freely.**

STEP	ACTION	SPEC	YES	NO
1.	Is the caster rotating freely?	—	Go to Step 2	Lubricate or Replace Caster Housing
2.	Is the wheel spinning freely?	—	Go to Step 3	Lubricate or Replace Wheel
3.	Is debris stuck in the rubber wheel?	—	Remove Debris or Replace Wheel	—

**Pot Hole Protection (PHP) Bars will not Lower**

---

**Check For These Obvious Conditions First:**

- Obstruction under pot hole bar on either side of machine.
- Obstruction around the actuator assembly at the base of the mast.

**Table 6-48. Pot Hole Protection (PHP) Bars will not Lower.**

STEP	ACTION	SPEC	YES	NO
1.	Check the actuator assembly and cables for adjustment or damage.	—	Adjust or Replace	Consult Factory

6.13 DRIVE SYSTEM TROUBLESHOOTING

Won't Climb Grade

Overview Of Procedure

The following procedure checks the drive motor and attached components for component failure, misadjustment due to wear.

Check For These Obvious Conditions First:

- Batteries are Fully Charged (24 Volts)
- Speed Control is Set to Maximum
- Is Grade within the Maximum Allowable Specification of 20% Grade
- Does the Travel Surface allow for Proper Drive Wheel Traction
- Is Platform Load within the Maximum Rated Capacity

Table 6-49. Won't Climb Grade

STEP	ACTION	SPEC	YES	NO
1.	Does machine drive straight on a level surface?	—	Go to Step 2	Refer to Machine Won't Drive Straight (Table 6-51)
2.	Are both the left and right drive motor, slip-clutches, located between the drive motor and the drive wheels, working properly?	—	Go to Step 3	Repair, Replace or Adjust Slip Clutch
3.	Do the left and right drive motor brakes release properly and allow the drive wheels to rotate freely?	—	Go to Step 4	Dragging? Repair, Replace or Adjust Brakes
4.	Check the amperage output of the on the drive motor leads. They should not exceed 100 amps while pulling a grade.	—	Controller will Shut Drive Down and will flash a 7 LED Code	Go to Step 5
5.	Check the condition of the drive motor brushes.	—	OK, go to Step 6	Worn down, replace brushes or drive motor
6.	If all above is OK, Drive motors are working properly. Consult Factory.	—	—	—



---

**Machine Drives in Opposite Direction**

---

**Table 6-50. Machine Drive in Opposite Direction**

STEP	ACTION	SPEC	YES	NO
1.	At the Traction Control Module, check if the left drive motor power lead is plugged into the M1 socket.  <b>NOTE:</b> <i>The left drive motor power lead uses a reverser harness between the module and the power lead to the motor.</i>	—	Go to Step 2	Switch the Left and Right Drive Motor Power Leads at the Traction Module
2.	Remove the Right Drive Motor power lead at the Traction Control Module (M2) and check if the WHITE wire is connected to the positive (+) terminal and the BLACK wire is connected to the negative (-) terminal. (Reference Figure 6-3., Electrical Diagram. (DVL/DVSP) (Sheet 1)	—	Go to Step 3	Rewire as Necessary
3.	Remove the Left Drive Motor power lead at the Traction Control Module (M1) and check if the BLACK wire is connected to the positive (+) terminal and the WHITE wire is connected to the negative (-) terminal. The Left Motor Power lead is reversed from the Right Motor lead due to the reverser harness. (Reference Figure 6-3., Electrical Diagram. (DVL/DVSP) (Sheet 1)	—	Consult Factory	Rewire as Necessary

## SECTION 6 - TROUBLESHOOTING

### Machine Won't Drive Straight

#### Overview Of Procedure

The following procedure examines the drive motor assembly weldments attaching the drive motors to the base frame. Also internal components of the drive motors, gear box and a check of the components between the gear box and the drive wheels.

#### Check For These Obvious Conditions First:

- Battery voltage 24 volts. (Fully charge batteries)
- Nothing is lodged between one of the wheels and the base frame.
- A caster wheel on the front of the machine is seized up, creating resistance.

**Table 6-51. Machine Won't Drive Straight.**

STEP	ACTION	SPEC	YES	NO
1.	Check for the following on the drive assembly, drive attachment weldments; is bent, has broken welds, or loose hardware.	—	Repair/Replace/ Tighten weldment	Go to Step 2
2.	Check for the following on the drive assembly, drive motor mounting plates; are bent, are square with drive weldments, or is hardware loose?	—	Repair/Replace/ Tighten weldment	Go to Step 3
3.	Check for the following on the drive assembly, drive motor hardware; is hardware loose, flange bearing - bad/loose, slip clutch - check torque settings or adjustment.	—	Repair/Replace/ Tighten component	Go to Step 4
4.	Check the left and right drive motor brakes for loose hardware & not releasing properly.	—	Tighten or Adjust per procedure in this Service Manual	Go to Step 5
5.	Is the electrical signal and amperage draw to the drive motors equal? Check with machine on level surface.	See Table 6-3.	Recheck Steps 1 thru 5	Go to Step 6
6.	Check the drive motor brushes, do they need replaced?	—	Replace per procedure in this Service Manual	Go to Step 7
7.	Calibrate joystick on Platform Control Console per procedure in Section-4 of this Service Manual. Does this fix the problem?	—	Done	Go to Step 8
8.	Is joystick control defective? If possible, swap out with another platform control.	—	Repair/Replace Platform control	Go to Step 9
9.	Is the Traction Control Module defective or connections not tight? If possible, swap out with another Traction Control Module.	—	Tighten Connections or Replace Traction Control Module	Go to Step 10
10.	Inside the drive motor gear box check if; the drive shaft is excessively loose & condition of drive shaft bearings. Are any gears broken or gear teeth excessively worn.	—	Repair/Replace gear box components per procedure in this Service Manual	

## Noise From Drive Assembly

### Overview Of Procedure

The following procedure examines the drive motor assembly weldments attaching the drive motors to the base frame. Also internal components of the drive motors, gear box and a check of the components between the gear box and the drive wheels.

### Check For These Obvious Conditions First:

- Battery voltage 24 volts. (Fully charge batteries)
- Nothing is lodged between one of the wheels and the base frame.
- A caster wheel on the front of the machine is seized up, creating resistance.

**Table 6-52. Noise from Drive Assembly.**

STEP	ACTION	SPEC	YES	NO
1.	Check for the following on the drive assembly, drive attachment weldment: is bent, has broken welds, or loose hardware.	—	Repair/Replace/ Tighten weldment	Go to Step 2
2.	Check for the following on the drive assembly, drive motor mounting plates; are bent, are square with drive weldments, or is hardware loose?	—	Repair/Replace/ Tighten weldment	Go to Step 3
3.	Check for the following on the drive assembly, drive motor hardware; is hardware loose, flange bearing - bad/loose, slip clutch - check torque settings or adjustment.	—	Repair/Replace/ Tighten Component	Go to Step 4
4.	Check the left and right drive motor brakes for loose hardware & not releasing properly.	—	Tighten or Adjust per procedure in this Service Manual	Go to Step 5
5.	Is the electrical signal and amperage draw to the drive motors equal? Check with machine on level surface.	See Table 6-3.	Recheck Steps 1 thru 5	Go to Step 6
6.	Check the drive motor brushes, do they need replaced?	—	Replace per procedure in this Service Manual	Go to Step 7
7.	Inside the drive motor gear box check if; the drive shaft is excessively loose & condition of drive shaft bearings. Are any gears broken or gear teeth excessively worn.	—	Repair/Replace gear box components per procedure in this Service Manual	

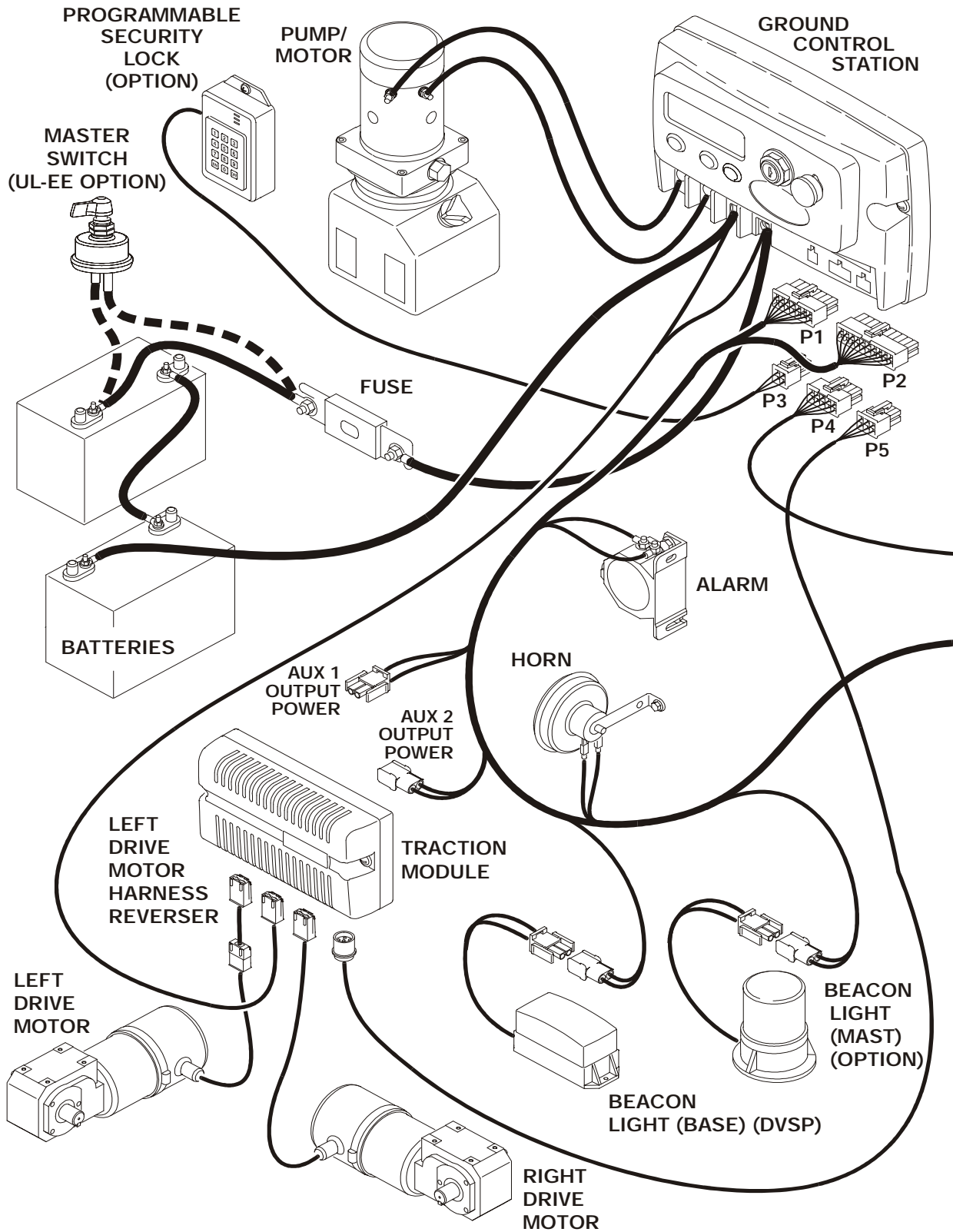

Figure 6-2. Overview of Electrical System Components. (DVL/DVSP) (Sheet 1 of 2)

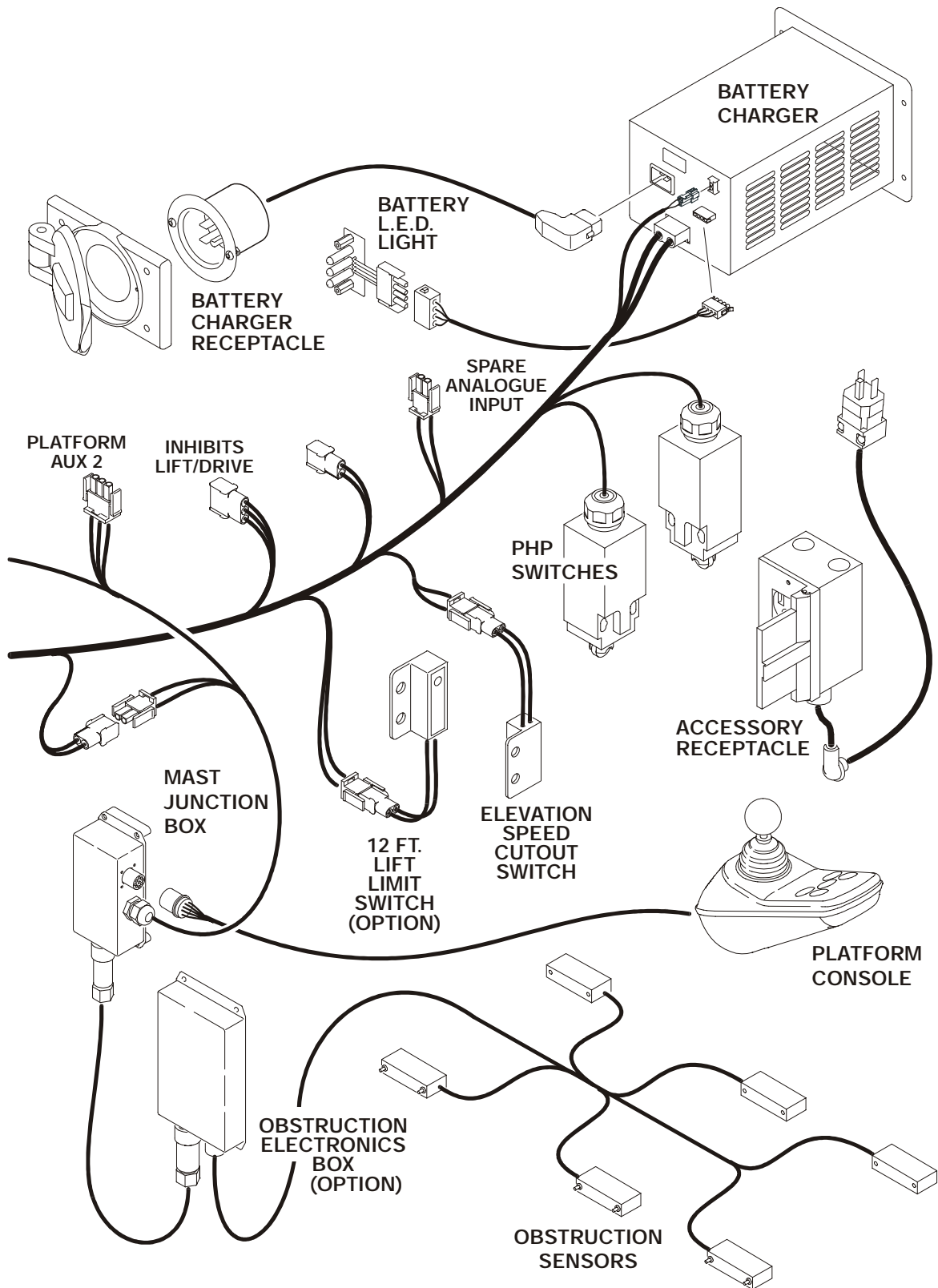

Figure 6-2. Overview of Electrical System Components. (DVL/DVSP) (Sheet 2 of 2)

SECTION 6 - TROUBLESHOOTING

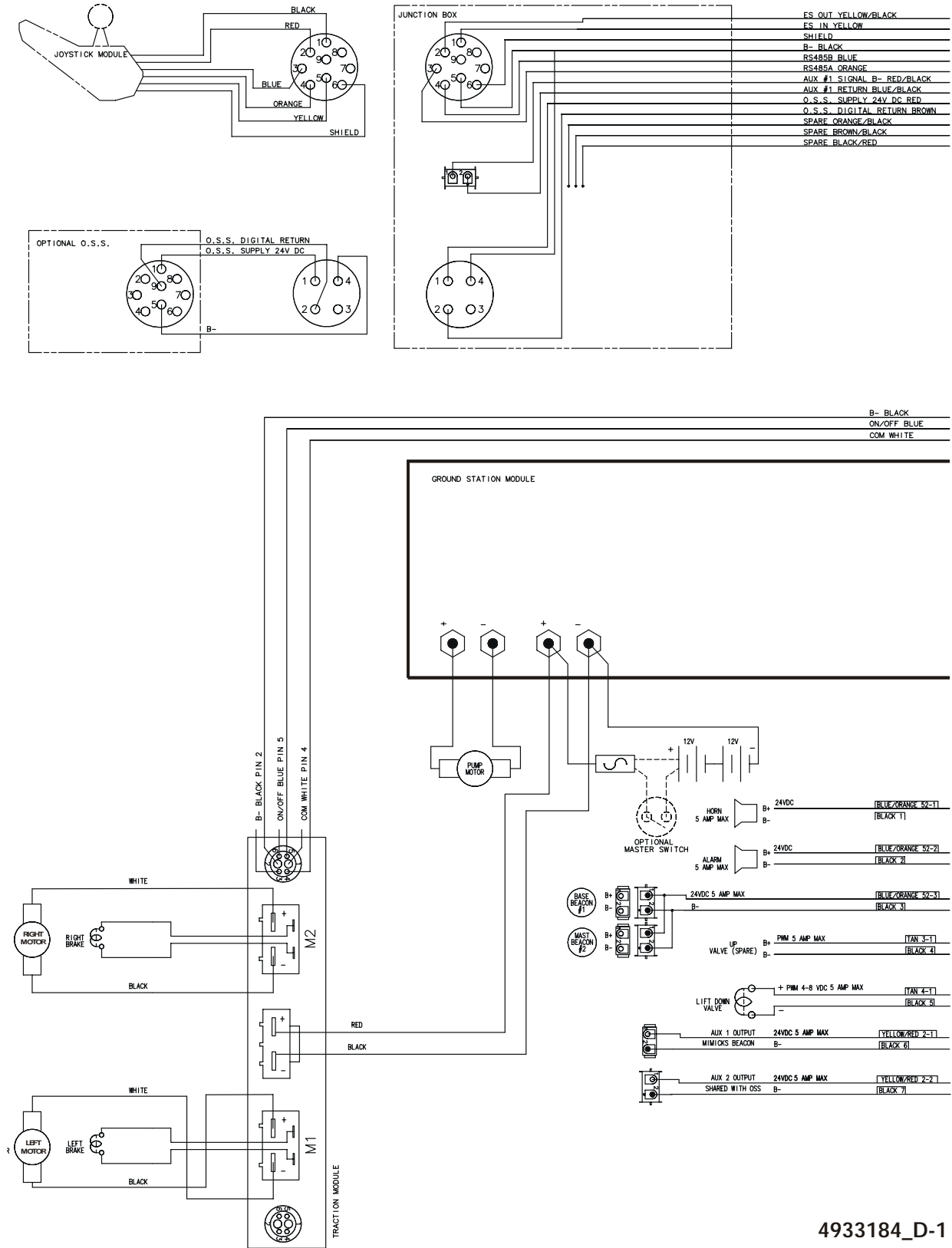

Figure 6-3. Electrical Diagram. (DVL/DVSP) (Sheet 1)

4933184\_D-1

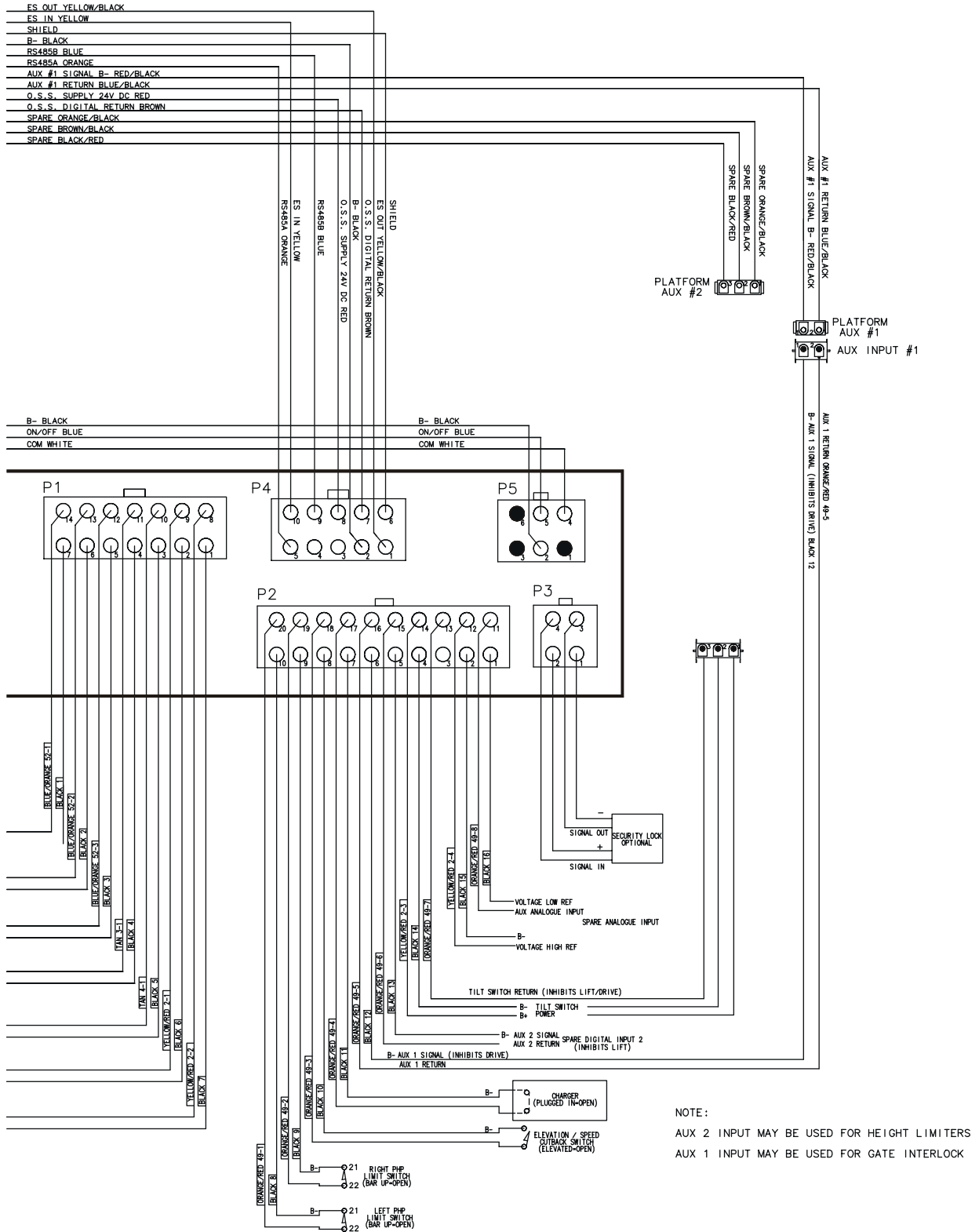

Figure 6-3. Electrical Diagram. (DVL/DVSP) (Sheet 1)

4933184\_D-1

SECTION 6 - TROUBLESHOOTING

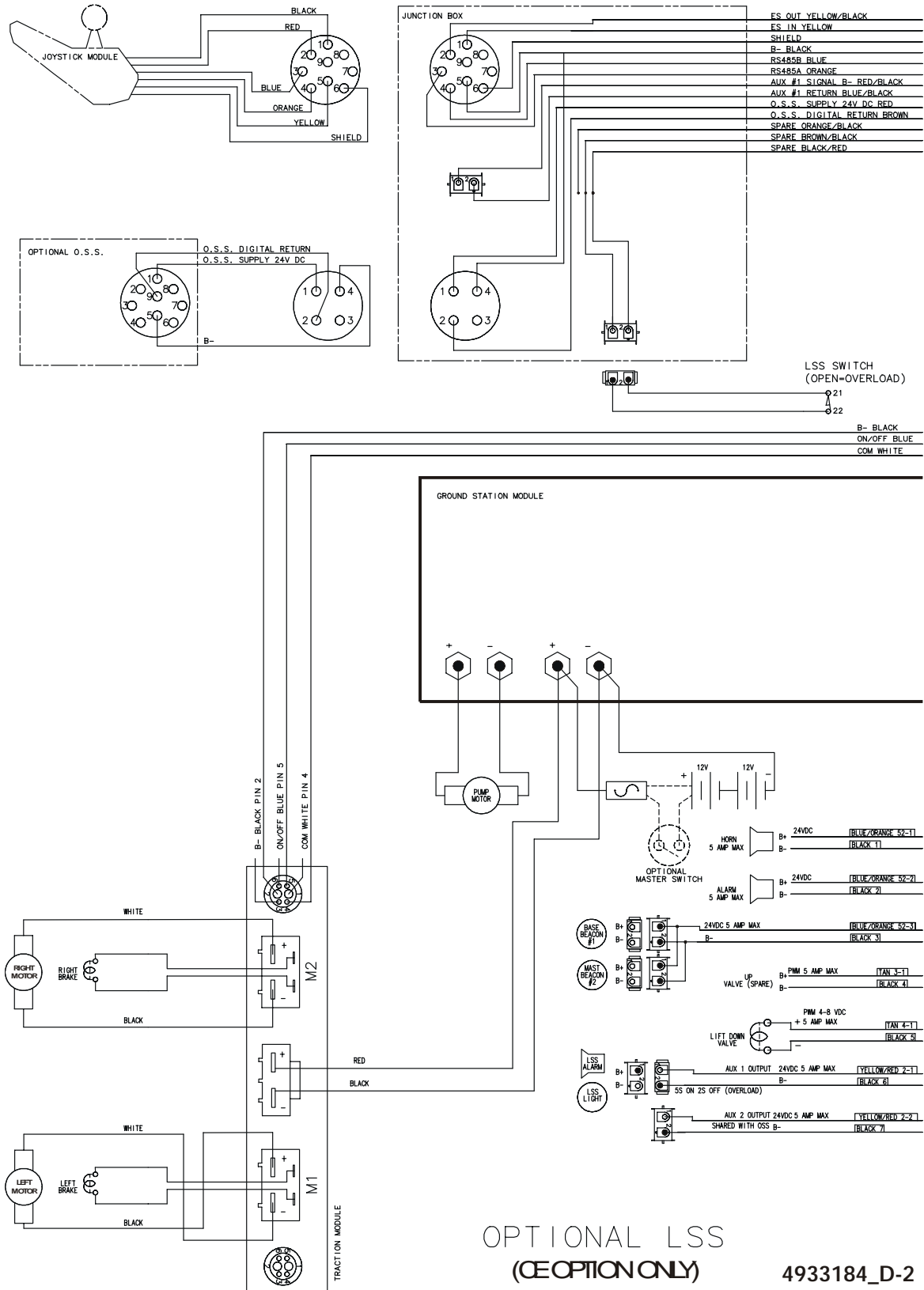

Figure 6-4. Electrical Diagram - (with Load Sensing System) (DVL/DVSP) (Sheet 2)



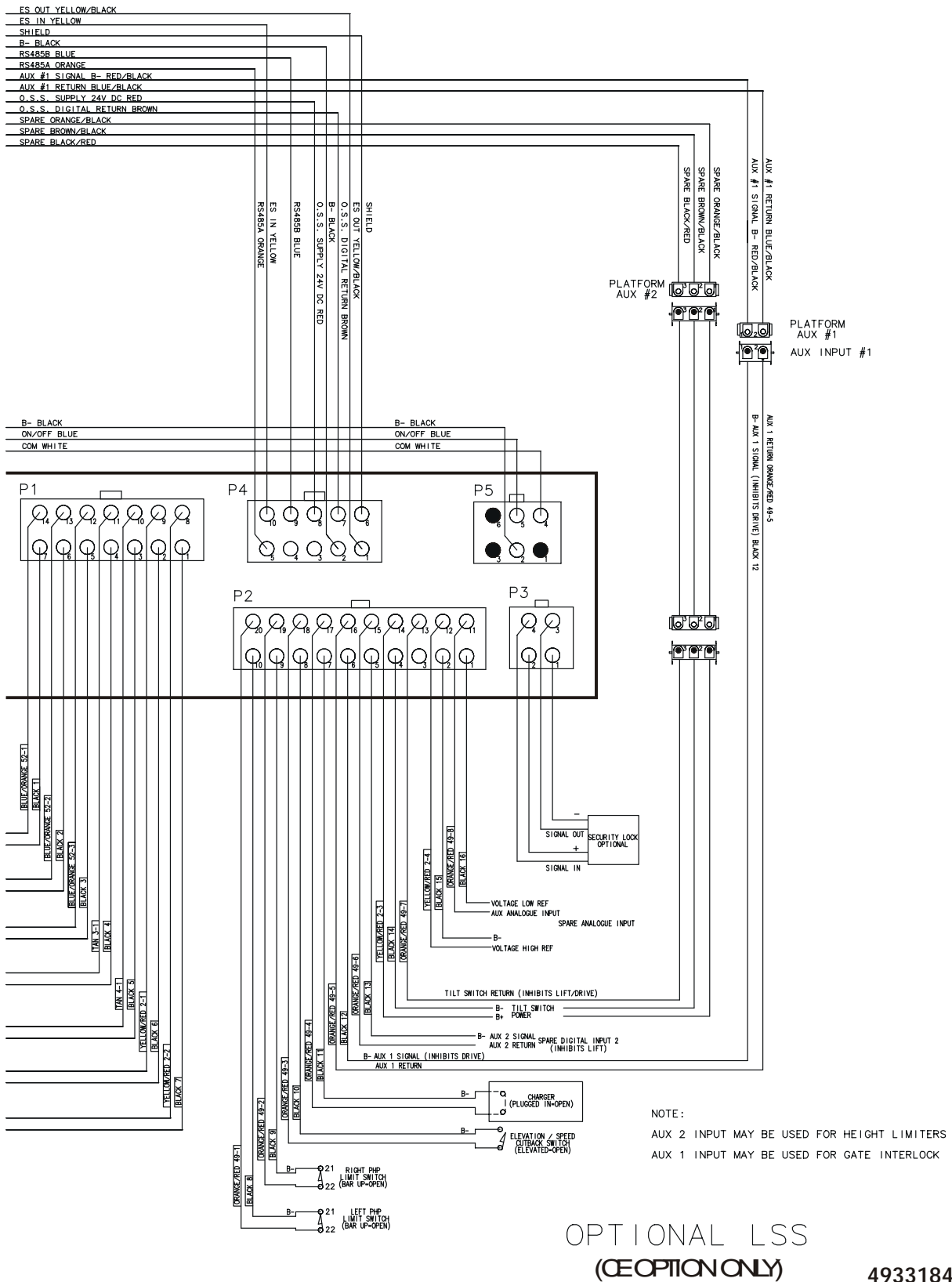

Figure 6-4. Electrical Diagram - (with Load Sensing System) (DVL/DVSP) (Sheet 2)

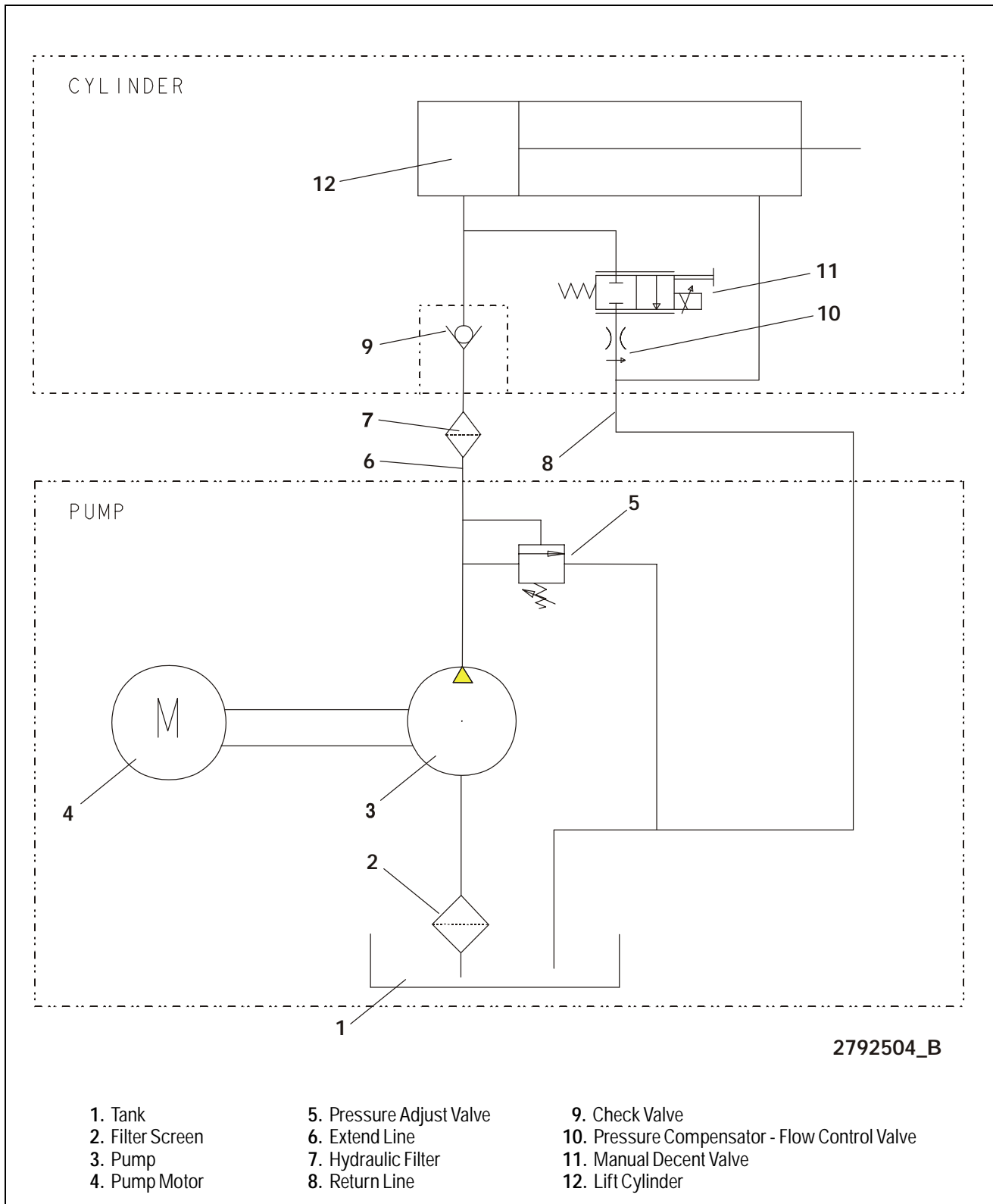

Figure 6-5. Hydraulic Diagram. (DVL/DVSP)

**CALIFORNIAN PROPOSITION 65**  
**BATTERY WARNING**

**Battery posts, terminals  
and related accessories  
contain lead and lead  
compounds, chemicals  
known to the State of  
California to cause cancer  
and reproductive harm.**

**Batteries also contain other  
harmful chemicals known  
to the State of California.**

**WASH HANDS  
AFTER HANDLING!**



Corporate Office  
JLG Industries, Inc.  
1 JLG Drive  
McConnellsburg PA. 17233-9533  
USA  
Phone: (717) 485-5161  
Fax: (717) 485-6417

## JLG Worldwide Locations

---

JLG Industries (Australia)  
P.O. Box 5119  
11 Bolwarra Road  
Port Macquarie  
N.S.W. 2444  
Australia  
Phone: (61) 2 65 811111  
Fax: (61) 2 65 810122

JLG Industries (UK)  
Unit 12, Southside  
Bredbury Park Industrial Estate  
Bredbury  
Stockport  
SK6 2sP  
England  
Phone: (44) 870 200 7700  
Fax: (44) 870 200 7711

JLG Deutschland GmbH  
Max Planck Strasse 21  
D-27721 Ritterhude/Ihlpohl  
Bei Bremen  
Germany  
Phone: (49) 421 693 500  
Fax: (49) 421 693 5035

JLG Industries (Italia)  
Via Po. 22  
20010 Pregnana Milanese - MI  
Italy  
Phone: (39) 02 9359 5210  
Fax: (39) 02 9359 5845

JLG Latino Americana Ltda.  
Rua Eng. Carlos Stevenson,  
80-Suite 71  
13092-310 Campinas-SP  
Brazil  
Phone: (55) 19 3295 0407  
Fax: (55) 19 3295 1025

JLG Europe B.V.  
Jupiterstraat 234  
2132 HJ Foofddorp  
The Netherlands  
Phone: (31) 23 565 5665  
Fax: (31) 23 557 2493

JLG Industries (Norge AS)  
Sofeimyrveien 12  
N-1412 Sofienyr  
Norway  
Phone: (47) 6682 2000  
Fax: (47) 6682 2001

JLG Polska  
Ul. Krolewska  
00-060 Warszawa  
Poland  
Phone: (48) 91 4320 245  
Fax: (48) 91 4358 200

JLG Industries (Europe)  
Kilmartin Place,  
Tannochside Park  
Uddingston G71 5PH  
Scotland  
Phone: (44) 1 698 811005  
Fax: (44) 1 698 811055

JLG Industries (Pty) Ltd.  
Unit 1, 24 Industrial Complex  
Herman Street  
Meadowdale  
Germiston  
South Africa  
Phone: (27) 11 453 1334  
Fax: (27) 11 453 1342

Plataformas Elevadoras  
JLG Iberica, S.L.  
Trapadella, 2  
P.I. Castellbisbal Sur  
08755Castellbisbal  
Spain  
Phone: (34) 93 77 24700  
Fax: (34) 93 77 11762

JLG Industries (Sweden)  
Enkopingsvagen 150  
Box 704  
SE - 175 27 Jarfalla  
Sweden  
Phone: (46) 8 506 59500  
Fax: (46) 8 506 59534

---